

6911 Southpoint Drive (B03)  
Burnaby, BC  
V3N 4X8

July 30, 2024

[REDACTED]

**RE: CEAP IR 77 - Survey Mountain Wind Project - Interconnection Feasibility Study Report**

Enclosed is the Interconnection Feasibility study report for the proposed Survey Mountain Wind Project submitted under Attachment M-2: Transmission Service and Interconnection Service Procedures for Competitive Electricity Acquisition Process (CEAP) of the Open Access Transmission Tariff (OATT). This letter provides a non-binding good faith estimate of the cost and time to construct the facilities required to interconnect your project to BC Hydro's Transmission System, being the Network Upgrades, based on the findings of the Interconnection Feasibility study.

**Open Access Transmission Tariff**

The OATT defines Network Upgrades as additions, modifications, and upgrades to BC Hydro's Transmission System required at or beyond the Point of Interconnection to accommodate the interconnection of the Generating Facility to the BC Hydro's Transmission System. Pursuant to the OATT, BC Hydro will design, procure, construct, install, and own the Network Upgrades. While BC Hydro will pay the costs for the Network Upgrades, the Interconnection Customer provides security for such costs.

**Cost Estimate**

Based on the Interconnection Feasibility study, the non-binding good faith estimated cost (typical accuracy range of +150%/-50%) for Network Upgrades required to interconnect your project is \$89.6M.

**Major Scope of Work Identified:**

- Acquire adequate property for a new substation close to the existing transmission line 2L170
- Construct a new outdoor 230kV, 3- circuit breaker ring bus switching substation
- Construct a new control building and other required substation facilities and infrastructures
- Supply and install protection relays and other required protection equipment
- Supply and install microwave towers, waveguides, antennas, and other required telecommunications equipment

**Exclusions:**

- GST
- Right-of-way
- Permits

**Key Assumptions:**

- Construction by contractor
- 3 years of construction
- No expansion of existing stations or control buildings to accommodate new equipment
- Early Engineering and Procurement
- No ground improvements will be required
- No piles will be required for construction
- No contaminated soil will be encountered during construction

**Key Risks:**

- Additional right of way or acquisition of more property may be required
- Transmission routing may be different than assumed, including number of disconnect switches and structure types may change leading to increased costs
- No defined supply chain strategy, construction costs may increase depending on delivery method
- Cost of construction may increase based on geotechnical condition of the actual project site
- Project schedule may be longer than expected, leading to increased costs
- Costs may be affected by market conditions and escalation

Please note that the Revenue Metering requirements and associated costs required to interconnect your project have not been determined at this stage and, therefore, not included in the above estimate. Revenue Metering costs that are attributable to the Interconnection Customer are to be paid in cash. For more details on Revenue Metering requirements and responsibilities, please refer to:

<https://www.bchydro.com/content/dam/BCHydro/customer-portal/documents/distribution/standards/ds-rmr-complex-revenue-metering.pdf>.

**Schedule**

Based on the Interconnection Feasibility study, the non-binding good faith estimated in-service date for your project's Network Upgrades is Quarter 3 2031 (calendar year). To achieve this timeline, we may need to expedite certain activities, including engineering design and procurement of long-lead equipment.

Timely actions required from you to minimize risks to the schedule:

- Submission of additional technical data required for the System Impact Study and Facilities Study
- Submission of any required information or document such as demonstration of Site Control
- Execution of Combined Study Agreement and Standard Generator Interconnection Agreement
- Financial commitments and securities

Please note that changes to your interconnection request, delays in data submission, or financial commitments may also impact the target in-service date.

**Next Steps**

In September 2024, we will issue a final invoice for the Feasibility Study costs. This invoice will reflect the total amount due, taking into account the \$15,000 Feasibility Study deposit you have already paid and any remaining amount on the non-refundable \$15,000 Interconnection request deposit that we did not spend in reviewing and validating your interconnection request.

If you have any questions, please contact the BC Hydro CEAP Team at [ceap2024@bchydro.com](mailto:ceap2024@bchydro.com).

Sincerely,

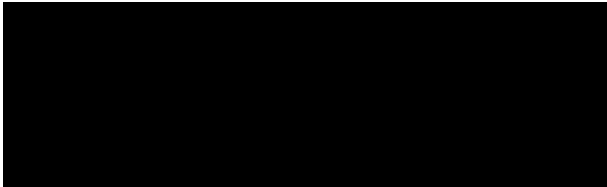

Senior Manager, Transmission Interconnections

BC Hydro

Encl.: CEAP2024\_IR\_77\_Survey Mountain Wind\_FeS\_Report\_final.pdf



# Survey Mountain Wind Project

## Interconnection Feasibility Study

**BC Hydro EGBC Permit to Practice No: 1002449**

**2024 CEAP IR # 77**

Prepared for:

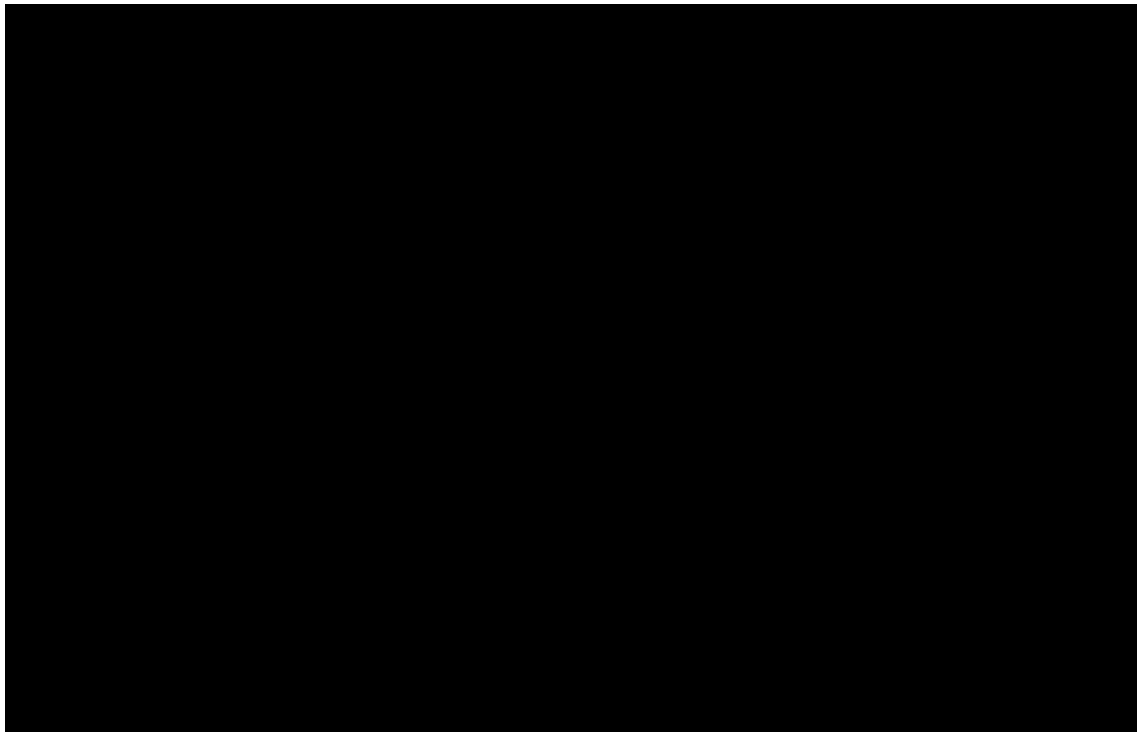



## Report Metadata

Header: Survey Mountain Wind Project  
Subheader: Interconnection Feasibility Study  
Title: Survey Mountain Wind Project  
Subtitle: 2024 CEAP IR # 77  
Report Number: 550-APR-00009  
Revision: 0  
Confidentiality: Public  
Date: 2024 Jul 30  
Volume: 1 of 1

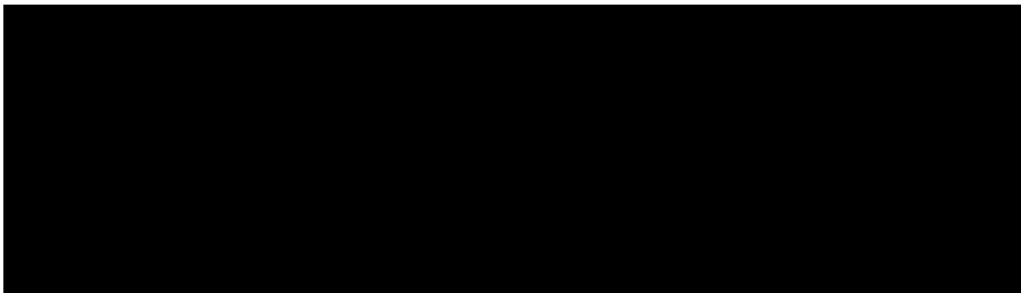

Related Facilities: 2L170  
Additional Metadata: Transmission Planning 2024-087  
Filing Subcode 1350



## Revisions

Revision	Date	Description
0	2024 Jul	Initial release



## Disclaimer of Warranty, Limitation of Liability

This report was prepared solely for internal purposes. All parties other than BC Hydro are third parties.

BC Hydro does not represent, guarantee or warrant to any third party, either expressly or by implication:

any information, product or process disclosed, described or recommended in this report.

BC Hydro does not accept any liability of any kind arising in any way out of the use by a third party of any information, product or process disclosed, described or recommended in this report, nor does BC Hydro accept any liability arising out of reliance by a third party upon any information, statements or recommendations contained in this report. Should third parties use or rely on any information, product or process disclosed, described or recommended in this report, they do so entirely at their own risk.

This report was prepared by the British Columbia Hydro And Power Authority ("BCH") or, as the case may be, on behalf of BCH by persons or entities including, without limitation, persons or entities who are or were employees, agents, consultants, contractors, subcontractors, professional advisers or representatives of, or to, BCH (individually and collectively, "BCH Personnel").

This report is to be read in the context of the methodology, procedures and techniques used, BCH's or BCH's Personnel's assumptions, and the circumstances and constraints under which BCH's mandate to prepare this report was performed. This report is written solely for the purpose expressly stated in this report, and for the sole and exclusive benefit of the person or entity who directly engaged BCH to prepare this report. Accordingly, this report is suitable only for such purpose, and is subject to any changes arising after the date of this report. This report is meant to be read as a whole, and accordingly no section or part of it should be read or relied upon out of context.

Unless otherwise expressly agreed by BCH:

- (a) any assumption, data or information (whether embodied in tangible or electronic form) supplied by, or gathered from, any source (including, without limitation, any consultant, contractor or subcontractor, testing laboratory and equipment suppliers, etc.) upon which BCH's opinion or conclusion as set out in this report is based (individually and collectively, "Information") has not been verified by BCH or BCH's Personnel; BCH makes no representation as to its accuracy or completeness and disclaims all liability with respect to the Information;
- (b) except as expressly set out in this report, all terms, conditions, warranties, representations and statements (whether express, implied, written, oral, collateral, statutory or otherwise) are excluded to the maximum extent permitted by law and, to the extent they cannot be excluded, BCH disclaims all liability in relation to them to the maximum extent permitted by law;
- (c) BCH does not represent or warrant the accuracy, completeness, merchantability, fitness for purpose or usefulness of this report, or any information contained in this report, for use or consideration by any person or entity. In addition, BCH does not accept any liability arising out of reliance by a person or entity on this report, or any information contained in this report, or for any errors or omissions in this report. Any use, reliance or publication by any person or entity of this report or any part of it is at their own risk; and
- (d) In no event will BCH or BCH's Personnel be liable to any recipient of this report for any damage, loss, cost, expense, injury or other liability that arises out of or in connection with this report including, without limitation, any indirect, special, incidental, punitive or consequential loss, liability or damage of any kind.

## Copyright Notice

Copyright and all other intellectual property rights in, and to, this report are the property of, and are expressly reserved to, BCH. Without the prior written approval of BCH, no part of this report may be reproduced, used or distributed in any manner or form whatsoever.









## Executive Summary

██████████ Inc, the interconnection customer (IC), requests to interconnect its Survey Mountain Wind Project (2024 CEAP IR # 77) to the BC Hydro (BCH) system. Survey Mountain Wind Project has thirty-six (36) ██████████ type-3 wind turbine generators, adding a total capacity of 200 MW to the BC Hydro system. The proposed Point of Interconnection (POI) is at a new switching station on BC Hydro's 230 kV line 2L170, approx. 22.4 km from Pike Lake substation (PIK). The IC's project will connect to the POI via a 10.6 km 230 kV interconnection line. The IC's proposed commercial operation date (COD) is Oct 1, 2029.

To interconnect the Survey Mountain Wind Project and its facilities to the BCH Transmission System at the proposed POI, this Feasibility Study has identified the following conclusions and requirements:

1. A new 230 kV switching station (referred to as "P77T") on 2L170 is required as the proposed POI for interconnecting the IC's generating project to the BCH system. With the new switching station P77T, 2L170 will be segregated into two new lines, temporarily referred to as: 2L170\_A (SAT-P77T) and 2L170\_B (P77T-PIK). The proposed new 230 kV customer-built interconnection line will be designated as 2L170\_C (P77T-P77). The temporary line designations will be replaced by permanent designations at a later stage of the interconnection study.
2. 2L170 is constructed to 500 kV standard, designed with the potential for future conversion to 500 kV operation, ensuring scalability to accommodate anticipated load growth and maintain supply reliability. BC Hydro presently does not foresee the need for conversion within the current planning horizon. Nevertheless, P77T must not compromise the feasibility of future voltage conversion. P77T planning and design is required to allow future upgrade to a 500/230 kV substation.
3. The connection of Survey Mountain Wind Project does not cause any performance violation (i.e. thermal overload, voltage performance violation or voltage stability concern) under system normal conditions or single contingency (P1 and P2) conditions.



4. In addition to entrance protection and line protection, the IC is required to install anti-islanding protection within their facility to disconnect the IC's wind farm from the grid when an inadvertent island with the local loads forms.
5. The new lines 2L170\_A and 2L170\_B will remain as part of BCH Bulk Electric System. The new line 2L170\_C will become an IC's BES line and the IC will be responsible for the compliance with applicable MRS requirements.
6. BC Hydro will provide line protections for 2L170\_A, 2L170\_B and 2L170\_C protections (BC Hydro end only). As part of the line protection replacements for each of the three lines, telecommunication facilities will be required to accommodate the new protection schemes. The IC shall provide required relays, telecom facility and associated equipment at its facilities to accommodate the new protection schemes.

The above conclusions are made based on the IC's input data and study assumptions listed in Section 4, which represent the best available information on May 22, 2024.

A non-binding good faith estimated cost and time to construct the Network Upgrades required to interconnect the proposed project will be provided in a separate letter to the IC.



# Contents

<b>Executive Summary</b>	<b>vii</b>
<b>1 Introduction</b>	<b>3</b>
<b>2 Purpose and Scopes of Study</b>	<b>6</b>
<b>3 Standard and Criteria</b>	<b>7</b>
<b>4 Assumptions and Conditions</b>	<b>8</b>
<b>5 System Studies and Results</b>	<b>9</b>
5.1 Power Flow Study Results	10
5.1.1 Branch Loading Analysis	10
5.1.2 Steady-State Voltage Analysis	10
5.1.3 Reactive Power Capability Evaluation	10
5.1.4 Anti-Islanding Requirements	11
5.2 Fault Analysis	11
5.3 Stations Requirements	11
5.4 Protection & Control Requirements	12
5.5 Telecommunications Requirements	13
<b>6 Cost Estimate and Schedule</b>	<b>14</b>
<b>7 Conclusions</b>	<b>15</b>

## Appendices

Appendix A	Plant Single Line Diagram Used for Power Flow Study
Appendix B	One-Line Sketch for New Switching Station
Appendix C	Conceptual One-Line Sketch for the New Switching Station After Potential Conversion to 500/230 kV substation



## Acronyms

The following are acronyms used in this report.

AIS	Air-Insulated Switchgear
BCH	BC Hydro
CEAP	Competitive Electricity Acquisition Process
COD	Commercial Operation Date
DTT	Direct Transfer Trip
ERIS	Energy Resource Interconnection Service
FeS	Feasibility Study
IBR	Inverter-Based Resources
IC	Interconnection Customer
LAPS	Local Area Protection Schemes
MPO	Maximum Power Output
NERC	North American Electric Reliability Corporation
NRIS	Network Resource Interconnection Service
OATT	Open Access Transmission Tariff
POI	Point of Interconnection
RAS	Remedial Action Scheme
STATCOM	Static Synchronous Compensator
TIR	BC Hydro “60 kV to 500 kV Technical Interconnection Requirements for Power Generators”
WECC	Western Electricity Coordinating Council
WTG	Wind Turbine Generator
BRU	Bruce Peak Microwave Repeater
EDM	Edmonds Office
FVO	Fraser Valley Office
PIK	Pike Lake Substation
SAT	Sahtlam Substation
SIO	South Interior Office
P77	Survey Mountain Wind (unofficial site code, customer owned)
P77T	Survey Mountain Terminal Station (unofficial site code)
PRC	Protection and Control



PPIS Power Parameter Information System



# 1 Introduction

Table 1-1 below summarizes the project reviewed in this Feasibility Study.

Table 1-1 Summary of Project Information

Project Name	Survey Mountain Wind Project- 2L170- 200 MW	
Name of Interconnection Customer (IC)	[REDACTED]	
Point of Interconnection (POI)	Switching Station on 2L170 at 22.4 km from PIK	
IC's Proposed COD	1st October 2029	
Type of Interconnection Service	NRIS <input checked="" type="checkbox"/>	ERIS <input type="checkbox"/>
Maximum Power Injection <sup>1</sup> (MW)	200 (Summer)	200(Winter)
Number of Generator Units	36 x 5.7 MW	
Plant Fuel	Wind	

[REDACTED] Inc, the interconnection customer (IC), requests to interconnect its Survey Mountain Wind Project (2024 CEAP IR # 77) to the BC Hydro (BCH) system. Survey Mountain Wind Project has thirty-six (36) [REDACTED] type-3 wind turbine generators, adding a total capacity of 200 MW to the BC Hydro system. The IC's proposed Point of Interconnection (POI) is at a new switching station on BC Hydro's 230 kV line 2L170, approx. 22.4 km from Pike Lake substation (PIK). The IC's project will connect to the POI via a 10.6 km 230 kV interconnection line. The IC's proposed commercial operation date (COD) is Oct 1, 2029.

Figure 1-1 shows the South Vancouver Island region 132/230 kV transmission system diagram.

A new switching station, temporarily designated P77T, would be required for Survey Mountain Wind Project interconnection to the existing 2L170. 2L170 would be looped in and out of P77T. 2L170 between P77T and PIK will be redesignated temporarily as 2L170\_B, and 2L170 between P77T and SAT will be redesignated temporarily as 2L170\_A. Survey Mountain Wind will connect to P77T with a 230 kV line designated temporarily as 2L170\_C.

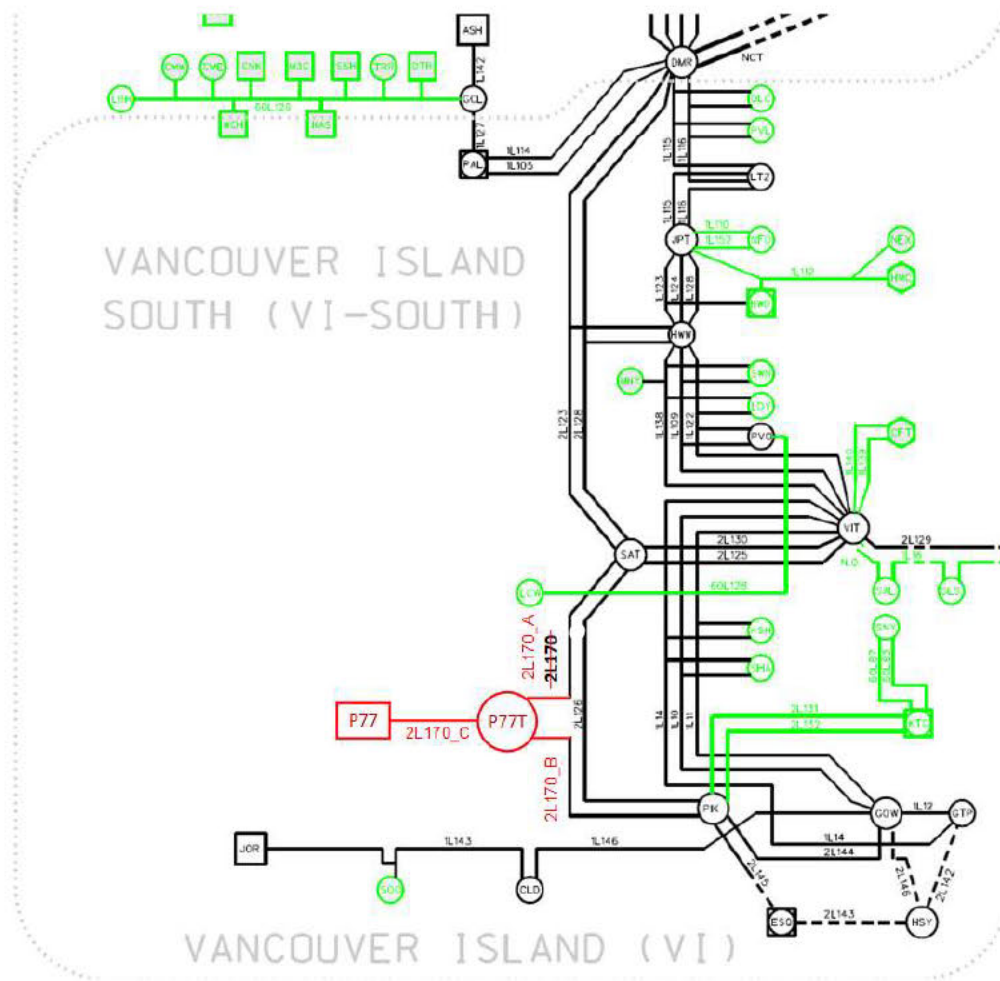

Figure 1-1: South VI 132/230 kV Transmission System Diagram in 2024 with the Proposed Survey Mountain Wind Project interconnection

In the Vancouver Island Bulk system, Vancouver Island - Transmission Reinforcement Completion (VITRC) project is the major capital project in identification phase with target ISD of 2029. This project is scoped to upgrade 1L18 VIT-ARN from 132 kV to 230 kV and redesignate to 2L124.

In the South Vancouver Island, Colwood (CLD) Area Study project is the major capital project currently in identification phase with target ISD of 2030. This project is scoped to build a new 230/132/25kV Goldstream Substation (GOL) in the northwest area of city of Langford to offload existing Colwood Substation (Colwood). The transmission component of this project includes two 230 kV parallel line from GOL to Pike Lake substation (PIK) and loop the existing 132 kV transmission circuits 1L143 and 1L146 in-and-out the GOL substation.





The existing transmission line, 2L170 (SAT-PIK) operating at 230 kV, is serving as part of a critical transfer cut-plane facilitating power to the Vancouver Island major load center. Constructed to meet the 500 kV standard, it was designed with the potential for future operation at 500 kV, ensuring scalability to accommodate anticipated load growth and maintain supply reliability.



## 2 Purpose and Scopes of Study

This Feasibility Study is a preliminary evaluation of the system impact of interconnecting the proposed project to the BC Hydro system based on power flow and short circuit analysis in accordance with BCH's Open Access Transmission Tariff (OATT). A non-binding good faith estimated cost of required Network Upgrades and estimated time to construct will be provided.

Per OATT, the feasibility study is performed individually for each of the participating projects in the CEAP and focuses specifically on the BC Hydro regional transmission system where the proposed generating project is proposed to be constructed. An assessment of the incremental effect on the 500kV bulk transmission system is beyond this study scope.

This is a "limited scope" study which is restricted to power flow studies of P0, P1 and P2 planning events as defined in TPL-001-4 and short circuit analysis. The study does not address other technical aspects such as transient stability and switching transients and impact of multiple contingencies. These subjects would be addressed in subsequent System Impact Study if the project is a Successful Participant of the CEAP.

In case impact to the adjacent external systems to BC Hydro is observed, such impact would be addressed in subsequent detailed and coordinated studies with the relevant adjacent entities if the proposed interconnection proceeds further.



### 3 Standard and Criteria

The Feasibility Study is performed in compliance with the North American Electric Reliability Corporation (NERC) and Western Electricity Coordinating Council (WECC) reliability standards, and the BCH interconnection requirements in the TIR, and upon the ratings of the existing BCH transmission facilities described in Operating Orders, specifically:

- NERC standards: TPL-001-4 and FAC-002-3 relevant to the scope of this Feasibility Study.
- WECC criteria TPL-001-WECC-CRT-4 Transmission System Planning Performance, July 1, 2023.
- BC Hydro's 60 kV to 500 kV Technical Interconnection Requirements for Power Generators.
- BC Hydro Operating Order 5T-10, Ratings for All Transmission Circuits 60 kV or Higher, April 16, 2024.
- BC Hydro Operating Order 5T-14, Ratings for All Transmission and Distribution Transformer, November 8, 2022.
- BC Hydro System Operating Order 7T-22 System Voltage Control, September 19, 2023.



## 4 Assumptions and Conditions

This Feasibility Study is performed based on the IC's submitted data and information available to BC Hydro on May 22, 2024 for the study purpose. Appendix A shows the plant single line diagram for the IC's project used in the study model. Certain assumptions were, as set out below, made to the extent required.

The power flow study cases used in this Feasibility Study are established based upon the BC Hydro's base resource plan and load forecasts available at the time of performing the study, which includes existing and future generations, transmission facilities, and loads in addition to the subject interconnection project in this study. Applicable seasonal conditions and the appropriate study years for the study planning horizon are also incorporated.

Additional assumptions are listed as follows.

- 1) The regional generation are dispatched to the patterns that stress the transmission system in the study area. In these patterns, the regional generations are typically set to their Maximum Power Outputs (MPO) unless otherwise specified.
- 2) The target in-service date for Vancouver Island - Transmission Reinforcement Completion project is March 2029 at the time of performing this SIS.
- 3) The projected in-service date for CLD Integrated Area Study capital project is March 2030 at the time of performing this SIS.
- 4) In case of discrepancy between GIDF form and PSSE case provided by customer, the PSSE case provided by the customer is used for this Feasibility study.



## 5 System Studies and Results

Based upon the IC's submitted information and the area system conditions, a new 230 kV switching station (referred to as "P77T") as the proposed POI on 2L170 is required to interconnect the IC's generating project to the BCH system. The new switching station would help to maintain reliability and adequate protection performance to serve the existing customers and the new addition.

With the new switching station P77T, the existing line 2L170 will be segregated into two new lines, temporarily referred to as: 2L170\_A (SAT-P77T) and 2L170\_B (P77T-PIK). The proposed customer-built 230 kV interconnection line (P77T-P77) is designated as 2L170\_C. The temporary line designations will be replaced by permanent designations at a later stage of interconnection study.

The existing transmission line, 2L170 (SAT-PIK) operating at 230 kV, is serving as part of a critical transfer cut-plane facilitating power to the Vancouver Island major load center. Constructed to meet the 500 kV standard, it was designed with the potential for future operation at 500 kV, ensuring scalability to accommodate anticipated load growth and maintain supply reliability.

The decision to undertake such conversion hinges upon load forecasts and resource planning, with BC Hydro presently not foreseeing the need for conversion within the current planning horizon. Nevertheless, any planned interconnection and the establishment of a new switching station must not compromise the feasibility of future voltage conversion, which is vital for ensuring continued reliable power supply to the VI load center. Should the conversion of 2L170 to 500 kV operation become necessary, the proposed new 230 kV switching station will be required to be upgraded to a 500/230 kV substation.

The new interconnection line 2L170\_C (P77T - P77) will become an IC's Bulk Electric System (BES) line and the IC will be responsible for the compliance with applicable Mandatory Reliability Standards (MRS) requirements.



## **5.1 Power Flow Study Results**

Power flow studies were performed to evaluate whether the IC's generating project would cause any unacceptable system performance (e.g. equipment overloads, steady-state voltage violation and voltage instability) and to determine the reinforcement requirement based on steady state performance analysis.

The study focuses on the 2031 light summer (31LS) system load condition which is typically a stressed condition for a generation interconnection project, taking into considerations of factors such as load conditions, seasons and generation patterns. The 2031 heavy summer (31HS) and 2031 heavy winter (31HW) cases are also checked at a high level to capture any possibility of performance violations under high load conditions.

### **5.1.1 Branch Loading Analysis**

The study finds no transformer or line overload under system normal (P0) or single contingencies (P1 and P2) conditions.

### **5.1.2 Steady-State Voltage Analysis**

With the connection of the IC's project, the voltage performance under system normal condition and single contingencies is acceptable for all the three load conditions (31LS, 31HS, 31HW).

### **5.1.3 Reactive Power Capability Evaluation**

The BC Hydro TIR requires IBR power plant to have the dynamic reactive power capability at a minimum of +/- 33% of its MPO at the high voltage side of the IC's switchyard over the full MW operating range.

Based on the PSS/E power flow data submitted by the IC, the proposed generating project would be capable to meet the BC Hydro's reactive capability requirement at the plant's maximum MW output, which is subjected to further verification in the next stage of interconnection study.

Furthermore, the BCH TIR requires the IC's project to provide sufficient reactive power capability over full MW operating range including at zero MW output level. According to the IC-provided information, the proposed WTG has 0 Mvar reactive capability at zero MW output, which needs to be re-confirmed if the IC's project



proceeds further. The proposed wind farm dynamic reactive power capability, as per information provided by the IC to BC Hydro to date, do not meet the minimum of +/- 33% of its MPO at zero MW output, which will needs to be addressed in the next stage of the interconnection study.

#### **5.1.4 Anti-Islanding Requirements**

The IC is required to install anti-islanding protection within its facility to disconnect the IC's wind farm from the grid when an inadvertent island with the local load forms.

### **5.2 Fault Analysis**

The short circuit analysis in the FeS is based upon the latest BC Hydro system model, which includes the generating facility information and associated impedance data provided by the IC. A more detailed study will be performed at the system impact study stage if needed.

### **5.3 Stations Requirements**

A new outdoor 230 kV, 3-circuit breaker ring bus AIS switching station (P77T temporarily) will be built at POI, close to the existing 230 kV transmission line 2L170. The existing transmission line 2L170 will be cut and looped in to, and 230 kV line of Survey Mountain Wind 2L170\_C will be terminated at the new switching station.

The station upgrade scope at the new switching station P77T is as follows.

- Acquire adequate property for a new substation close to the existing transmission line 2L170. The property size must allow the future 500 kV conversion at this location.
- Construct a new outdoor 230 kV, 3- circuit breaker ring bus AIS switching substation. Refer to Appendix B for One-Line Sketch for New Switching Station for details
- Construct a new control building and other required substation facilities and infrastructures.
- Cut the existing 2L170 and loop into the switching station.
- Terminate 230 kV line of Survey Mountain Wind at the station.

500 kV future conversion



- The conceptual ultimate planning one-line for this substation is required to include a future 500 kV section. A conceptual ultimate planning one-line drawing has been provided to illustrate the 500 kV section's functional requirements. Refer to Appendix C: Conceptual One-Line Sketch for the New Switching Station After Potential Conversion to 500/230 kV substation for details. This conceptual drawing is provided for information only. The actual ultimate planning one-line will be studied and provided at a later stage, as needed.

## 5.4 Protection & Control Requirements

BC Hydro will provide line protections for 2L170\_A, 2L170\_B and 2L170\_C protections (BC Hydro end only).

The IC is to provide the following for the interconnection of Survey Mountain Wind Project:

- Entrance protection that complies with the latest version of the “60 kV to 500 kV BC Hydro Technical Interconnection Requirements for Power Generators.”
- Provide two SEL-411L-1 relays (firmware and options specified by BC Hydro) at the entrance of P77 to provide protection coverage for 2L170\_C. BC Hydro P&C Planning will provide core protection settings for these relays to protect transmission line 2L170\_C during a transmission line fault. Non-core protection such as local breaker failure, auto-reclosing, backup protection for station elements will not be provided by BC Hydro P&C Planning.
- The IC is responsible for NERC PRC-related tasks, settings to compliance standards within their facilities.
- The IC is responsible for providing a communications link for remote interrogation of the PPIS equipment by BCH servers.
- Provide anti-islanding protection as stated in Section 5.1

If the proposed project proceeds through the CEAP process, subsequent System Impact Studies may identify RAS requirements for this interconnection. These RAS functional requirements will include initiating events, control actions, and latency times. Depending on these supplementary requirements, additional telecommunication facilities may be needed to facilitate signal transmission between the BC Hydro substations and customer facilities.





## 5.5 Telecommunications Requirements

BC Hydro performed a high-level feasibility assessment of a telecom solution to meet the following requirements.

### Teleprotection Requirements for Telecom

- Provide WECC Level 3 64 kbps synchronous circuits between SAT and P77T for “SAT-P77T 2L170\_A PY DIGITAL TELEPROT” and “SAT and P77T for “SAT-P77T 2L170\_A SY DIGITAL TELEPROT”. Physical interface shall be C37.94 optical over multimode fibre using ST connectors.
- Provide WECC Level 3 64 kbps synchronous circuits between PIK and P77T for “PIK-P77T 2L170\_B PY DIGITAL TELEPROT” and “PIK-P77T 2L170\_B SY DIGITAL TELEPROT”. Physical interface shall be C37.94 optical over multimode fibre using ST connectors.
- Provide WECC Level 3 64 kbps synchronous circuits between P77T and P77 for “P77T-P77T 2L170\_C PY DIGITAL TELEPROT” and “P77T - P77 2L170\_C SY DIGITAL TELEPROT”. Physical interface shall be C37.94 optical over multimode fibre using ST connectors.

### Telecontrol Requirements for Telecom

- Provide P77T SCADA circuits to FVO and SIO.
- Provide P77 SCADA circuits to FVO and SIO.

Certain assumptions were made for determining a potential telecom solution. Details of the telecom solution (e.g. assumptions made, alternatives investigated and work required for BCH and the IC) would be provided at the next study stage.



## **6 Cost Estimate and Schedule**

The non-binding good faith estimated cost and time to construct the Network Upgrades required to interconnect the proposed project will be provided in a separate letter to the IC.



## 7 Conclusions

To interconnect the Survey Mountain Wind Project and its facilities to the BCH Transmission System at the POI, this Feasibility Study has identified the following conclusions and requirements:

1. A new 230 kV switching station (referred to as “P77T”) on 2L170 is required as the proposed POI for interconnecting the IC’s generating project to the BCH system. With the new switching station P77T, 2L170 will be segregated into two new lines, temporarily referred to as: 2L170\_A (SAT-P77T) and 2L170\_B (P77T-PIK). The proposed customer-built 230 kV interconnection line (P77T- P77) will be designated as 2L170\_C . The temporary line designations will be replaced by permanent designations at a later stage of interconnection study.
2. 2L170 is constructed to 500 kV standard, designed with the potential for future conversion to 500 kV operation, ensuring scalability to accommodate anticipated load growth and maintain supply reliability. BC Hydro presently does not foresee the need for conversion within the current planning horizon. Nevertheless, P77T must not compromise the feasibility of future voltage conversion. P77T planning and design is required to allow future upgrade to a 500/230 kV substation.
3. The connection of Survey Mountain Wind Project does not cause any performance violation (i.e. thermal overload, voltage performance violation or voltage stability concern) under system normal conditions or single contingency (P1 and P2) conditions.
4. In addition to entrance protection and line protection, the IC is required to install anti-islanding protection within their facility to disconnect the IC’s wind farm from the grid when an inadvertent island with the local loads forms.
5. The new lines 2L170\_A and 2L170\_B will remain as part of BCH Bulk Electric System. The new line 2L170\_C will become an IC’s BES line and the IC will be responsible for the compliance with applicable MRS requirements.
6. BC Hydro will provide line protections for 2L170\_A, 2L170\_B and 2L170\_C protections (BC Hydro end only). As part of the line protection



replacements for each of the three lines, telecommunication facilities will be required to accommodate the new protection schemes. The IC shall provide required relays, telecom facility and associated equipment at its facilities to accommodate the new protection schemes.



## Appendix A

### Plant Single Line Diagram Used for Power Flow Study

Figure A-1 shows Survey Mountain Wind Project single line diagram used for power flow study.

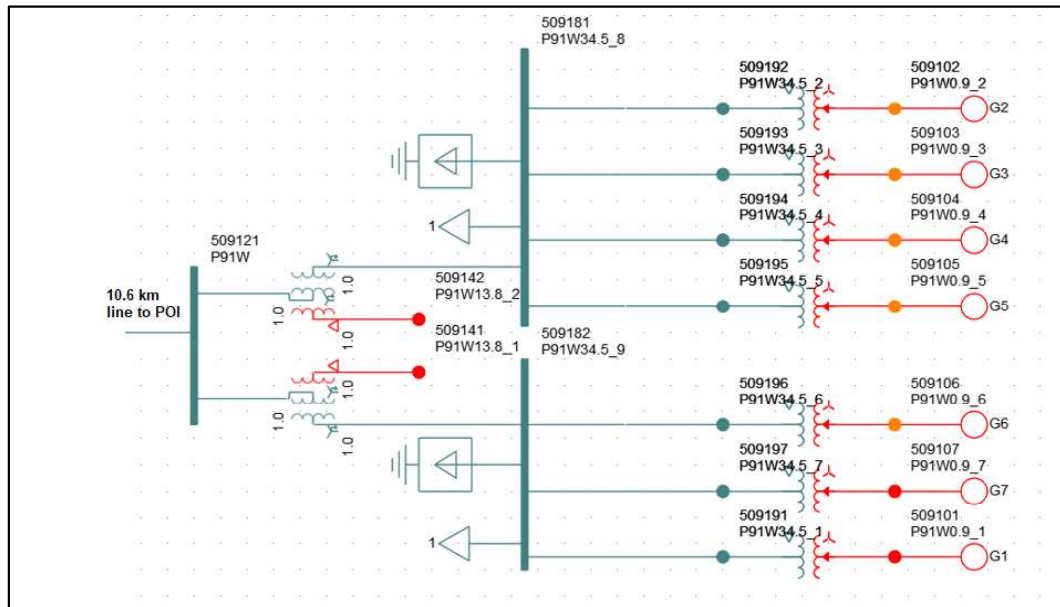

Figure A-1: Survey Mountain Wind Project Single Line Diagram for Power Flow Study.

As seen in the diagram, Survey Mountain Wind Project has two main power transformers dividing the plant into two parts.

- Part 1 has four (4) feeders connecting 21 wind turbines to the collector station, and a 5 Mvar STATCOM.
- Part 2 has three (3) feeders connecting 15 wind turbines to the collector station, and a 5 Mvar STATCOM.

## Appendix B

### One-Line Sketch for New Switching Station

Figure B-1 shows the Stations Planning One-Line Sketch for the New Switching Station P77T.

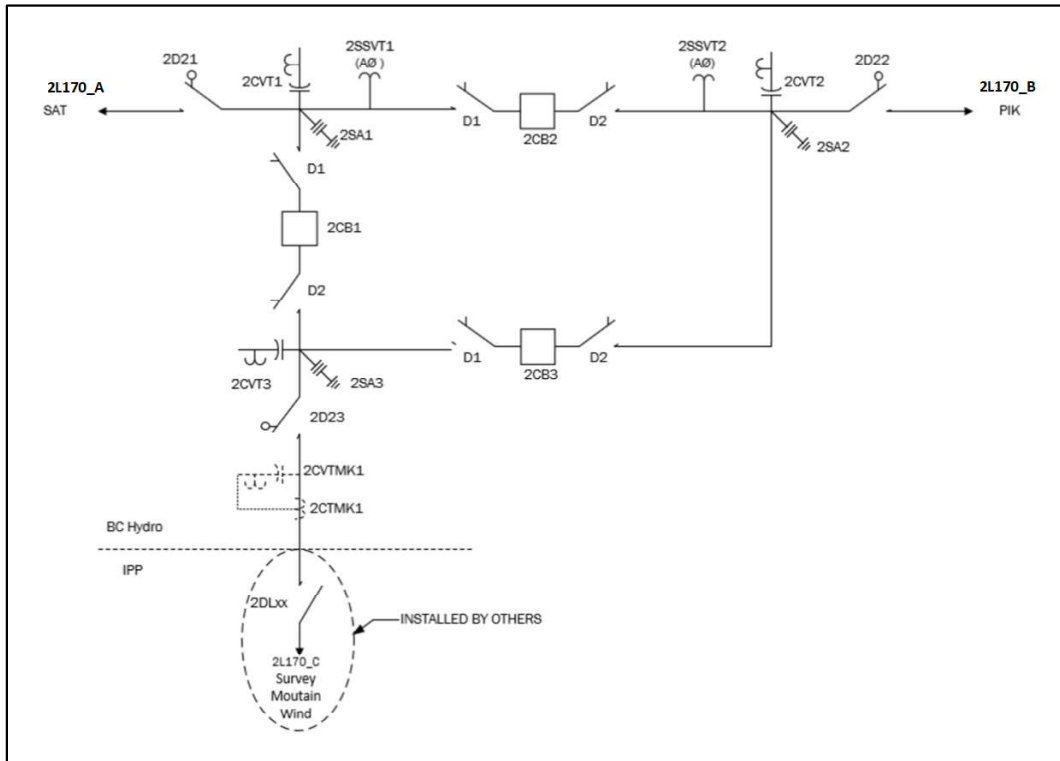

Figure B-1: Stations Planning One-Line Sketch for the New Switching Station P77T.

## Appendix C

### Conceptual One-Line Sketch for the New Switching Station After Potential Conversion to 500/230 kV substation

Figure C-1 shows the Stations Planning Conceptual One-Line Sketch for the New Switching Station P77T After Potential Conversion to 500/230 kV Substation.

This conceptual drawing is provided for information only. The actual ultimate planning oneline will be studied and provided at a later stage as needed.

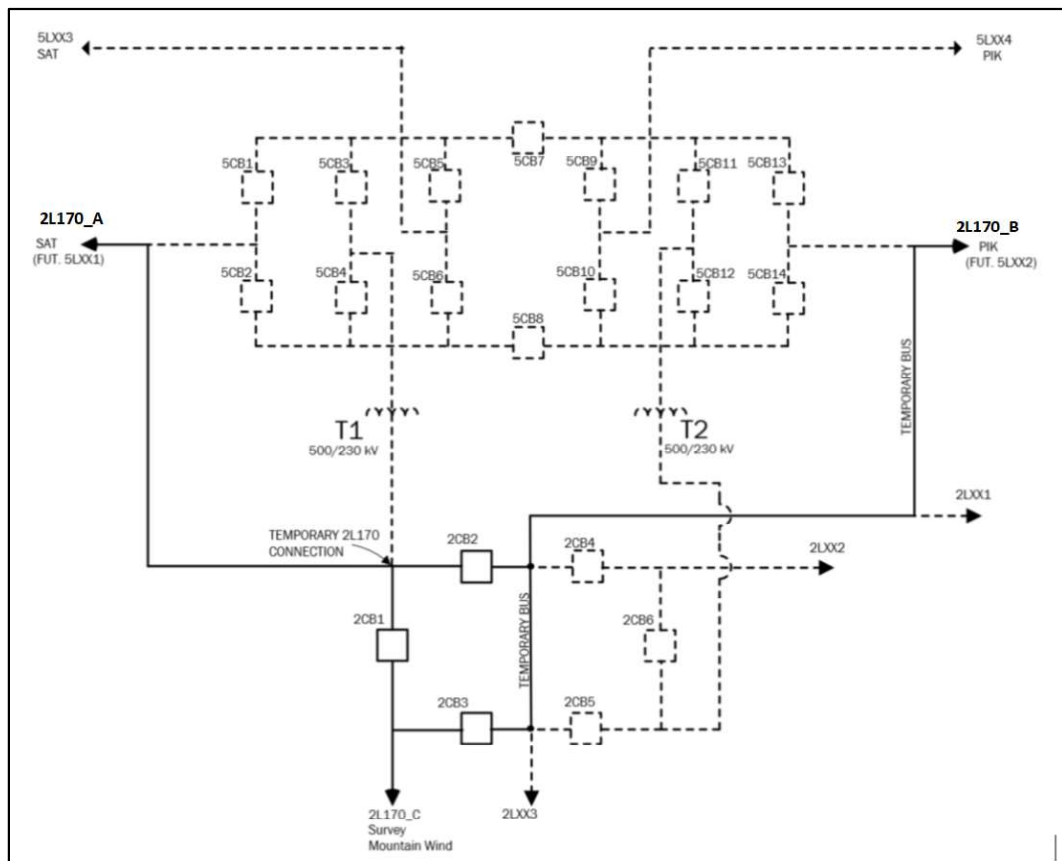

Figure C-1: Stations Planning Conceptual One-Line Sketch for the New Switching Station P77T After Potential Conversion to 500/230 kV Substation.



