

6911 Southpoint Drive (B03)
Burnaby, BC
V3N 4X8

July 30, 2024

[REDACTED]
[REDACTED]
[REDACTED]
[REDACTED]
[REDACTED]
[REDACTED]

RE: CEAP IR 18 - K2 Wind Project - Interconnection Feasibility Study Report

Enclosed is the Interconnection Feasibility study report for the proposed K2 Wind Project submitted under Attachment M-2: Transmission Service and Interconnection Service Procedures for Competitive Electricity Acquisition Process (CEAP) of the Open Access Transmission Tariff (OATT). This letter provides a non-binding good faith estimate of the cost and time to construct the facilities required to interconnect your project to BC Hydro's Transmission System, being the Network Upgrades, based on the findings of the Interconnection Feasibility study.

Open Access Transmission Tariff

The OATT defines Network Upgrades as additions, modifications, and upgrades to BC Hydro's Transmission System required at or beyond the Point of Interconnection to accommodate the interconnection of the Generating Facility to the BC Hydro's Transmission System. Pursuant to the OATT, BC Hydro will design, procure, construct, install, and own the Network Upgrades. While BC Hydro will pay the costs for the Network Upgrades, the Interconnection Customer provides security for such costs.

Cost Estimate

Based on the Interconnection Feasibility study, the non-binding good faith estimated cost (typical accuracy range of +150%/-50%) for Network Upgrades required to interconnect your project is \$79.9 M.

Major Scope of Work Identified:

- Acquire adequate property for a new substation close to the existing transmission line 1L244.
- Construct a new outdoor 138 kV, 3-circuit breaker ring bus switching substation
- Supply and install telecom towers, racks, waveguides and antennas
- Supply and install protection relays and other required protection equipment
- Supply and install digital teleprotection circuits and connect to protective equipment
- Other Telecom and Protection work, as required

Exclusions:

- GST
- Right-of-Way
- Permits

Key Assumptions:

- Construction will be done by contractor
- Early Engineering and Procurement
- 3 years of construction
- No expansion of existing station or control building to accommodate new equipment
- No ground improvements will be required
- No piles will be required for construction
- No contaminated soil will be encountered during construction

Key Risks:

- Additional right of way or acquisition of more property may be required
- Cost of obtaining new property for the new switching station may be higher than estimated which may significantly increase the project cost
- Cost of construction may increase based on geotechnical condition of the actual project site
- No defined supply chain strategy, construction costs may increase depending on delivery method
- Project schedule may be longer than expected, leading to increase loading costs
- Costs may be affected by market conditions and escalation

Please note that the Revenue Metering requirements and associated costs required to interconnect your project have not been determined at this stage and, therefore, not included in the above estimate. Revenue Metering costs that are attributable to the Interconnection Customer are to be paid in cash. For more details on Revenue Metering requirements and responsibilities, please refer to:

<https://www.bchydro.com/content/dam/BCHydro/customer-portal/documents/distribution/standards/ds-rmr-complex-revenue-metering.pdf>.

Schedule

Based on the Interconnection Feasibility study, the non-binding good faith estimated in-service date for your project's Network Upgrades is Quarter 3, 2031 (calendar year). To achieve this timeline, we may need to expedite certain activities, including engineering design and procurement of long-lead equipment.

Timely actions required from you to minimize risks to the schedule:

- Submission of additional technical data required for the System Impact Study and Facilities Study
- Submission of any required information or document such as demonstration of Site Control
- Execution of Combined Study Agreement and Standard Generator Interconnection Agreement
- Financial commitments and securities

Please note that changes to your interconnection request, delays in data submission, or financial commitments may also impact the target in-service date.

Next Steps

In September 2024, we will issue a final invoice for the Feasibility Study costs. This invoice will reflect the total amount due, taking into account the \$15,000 Feasibility Study deposit you have already paid and any remaining amount on the non-refundable \$15,000 Interconnection request deposit that we did not spend in reviewing and validating your interconnection request.

If you have any questions, please contact the BC Hydro CEAP Team at ceap2024@bchydro.com.

Sincerely,

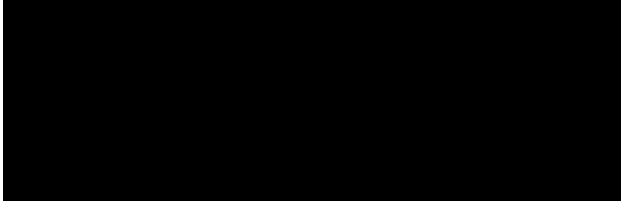

Senior Manager, Transmission Interconnections

BC Hydro

Encl.: CEAP2024_IR_18_K2 Wind_FeS_Report_final.pdf



K2 Wind Project

Interconnection Feasibility Study

BC Hydro EGBC Permit to Practice No: 1002449

2024 CEAP IR # 18

Prepared for:

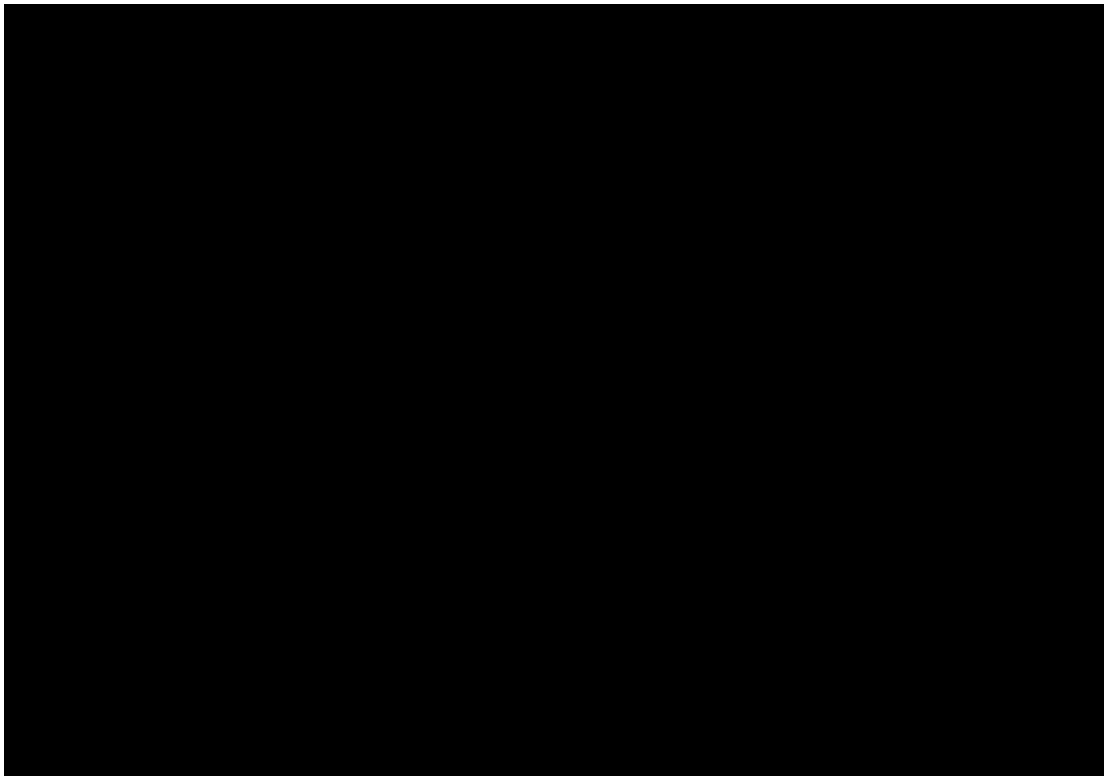



Report Metadata

Header: K2 Wind Project
Subheader: Interconnection Feasibility Study
Title: K2 Wind Project
Subtitle: 2024 CEAP IR # 18
Report Number: 300-APR-00009
Revision: 0
Confidentiality: Public
Date: 2024 Jul 30
Volume: 1 of 1

[Redacted text block]

Related Facilities: 1L244
Additional Metadata: Transmission Planning 2024-042
Filing Subcode 1350



Revisions

Revision	Date	Description
0	2024 Jul	Initial release



Disclaimer of Warranty, Limitation of Liability

This report was prepared solely for internal purposes. All parties other than BC Hydro are third parties.

BC Hydro does not represent, guarantee or warrant to any third party, either expressly or by implication:

any information, product or process disclosed, described or recommended in this report.

BC Hydro does not accept any liability of any kind arising in any way out of the use by a third party of any information, product or process disclosed, described or recommended in this report, nor does BC Hydro accept any liability arising out of reliance by a third party upon any information, statements or recommendations contained in this report. Should third parties use or rely on any information, product or process disclosed, described or recommended in this report, they do so entirely at their own risk.

This report was prepared by the British Columbia Hydro And Power Authority ("BCH") or, as the case may be, on behalf of BCH by persons or entities including, without limitation, persons or entities who are or were employees, agents, consultants, contractors, subcontractors, professional advisers or representatives of, or to, BCH (individually and collectively, "BCH Personnel").

This report is to be read in the context of the methodology, procedures and techniques used, BCH's or BCH's Personnel's assumptions, and the circumstances and constraints under which BCH's mandate to prepare this report was performed. This report is written solely for the purpose expressly stated in this report, and for the sole and exclusive benefit of the person or entity who directly engaged BCH to prepare this report. Accordingly, this report is suitable only for such purpose, and is subject to any changes arising after the date of this report. This report is meant to be read as a whole, and accordingly no section or part of it should be read or relied upon out of context.

Unless otherwise expressly agreed by BCH:

- (a) any assumption, data or information (whether embodied in tangible or electronic form) supplied by, or gathered from, any source (including, without limitation, any consultant, contractor or subcontractor, testing laboratory and equipment suppliers, etc.) upon which BCH's opinion or conclusion as set out in this report is based (individually and collectively, "Information") has not been verified by BCH or BCH's Personnel; BCH makes no representation as to its accuracy or completeness and disclaims all liability with respect to the Information;
- (b) except as expressly set out in this report, all terms, conditions, warranties, representations and statements (whether express, implied, written, oral, collateral, statutory or otherwise) are excluded to the maximum extent permitted by law and, to the extent they cannot be excluded, BCH disclaims all liability in relation to them to the maximum extent permitted by law;
- (c) BCH does not represent or warrant the accuracy, completeness, merchantability, fitness for purpose or usefulness of this report, or any information contained in this report, for use or consideration by any person or entity. In addition, BCH does not accept any liability arising out of reliance by a person or entity on this report, or any information contained in this report, or for any errors or omissions in this report. Any use, reliance or publication by any person or entity of this report or any part of it is at their own risk; and
- (d) In no event will BCH or BCH's Personnel be liable to any recipient of this report for any damage, loss, cost, expense, injury or other liability that arises out of or in connection with this report including, without limitation, any indirect, special, incidental, punitive or consequential loss, liability or damage of any kind.

Copyright Notice

Copyright and all other intellectual property rights in, and to, this report are the property of, and are expressly reserved to, BCH. Without the prior written approval of BCH, no part of this report may be reproduced, used or distributed in any manner or form whatsoever.



Executive Summary

█ the interconnection customer (IC), requests to interconnect its K2 Wind Project (2024 CEAP IR # 18) to the BC Hydro (BCH) system. K2 Wind Project has twenty-eight (28) █ type-3 wind turbine generators with total installed capacity of 159.6 MW. The proposed Point of Interconnection (POI) is on BC Hydro's 138 kV line 1L244, approx. 39 km from Nicola substation (NIC). The IC's project will connect to the POI via a 5 km 138 kV interconnection line. The IC's proposed commercial operation date (COD) is Oct 1, 2029.

To interconnect the K2 Wind Project and its facilities to the BCH Transmission System at the proposed POI, this Feasibility Study has identified the following conclusions and requirements:

1. A new 138 kV switching station (referred to as "P18T") on 1L244 is required at the proposed POI for interconnecting the IC's generating project to the BCH system. With the new switching station P18T, 1L244 will be segregated into three new lines, temporarily referred to as: 1L244_A (NIC-P18T), 1L244_B (P18T-WBK) and 1L244_C (P18T-P18). The temporary line designations will be replaced by permanent designations at a later stage of interconnection study.
2. The connection of K2 Wind Project does not cause any performance violation (i.e. thermal overload, voltage performance violation or voltage stability concern) under system normal conditions.
3. The connection of K2 Wind Project will cause an overload on 1L244_A (NIC-PSW tap) under single contingencies. If an overload on 1L244_A is detected, a signal from NIC will be initiated to shed or run back generation at the IC's facility. The overload detection mechanism and exact mitigation actions will be determined in discussion with BCH at the next study stage.
4. A direct transfer trip (DTT) from NIC to P18T is required to isolate the wind farm for protective and unintentional tripping of 1L244_A. In addition, the IC is required to install anti-islanding protection within their facility to disconnect the IC's wind farm from the grid when an inadvertent island with the local loads forms.



5. According to BC Hydro's TIR, the IC's project must have sufficient reactive power capability over full MW operating range including at the zero MW output level. The K2 wind farm as submitted does not meet the reactive capability requirement at zero MW output level, which will need to be addressed.
6. The line 1L244_A will become part of BC Hydro BES and need to be compliant with applicable NERC MRS requirements. The line 1L244_B (P18T-WBK) will remain as a non-BES line.
7. BC Hydro will provide line protections for 1L244_A, 1L244_B and 1L244_C (BC Hydro end only). As part of the line protection replacements for each of the three lines, telecommunication facilities will be required to accommodate the new protection schemes. The IC shall provide required relays, telecom facility and associated equipment at its facilities to accommodate the new protection schemes.

The above conclusions are made based on the IC's input data and study assumptions listed in Section 4, which represent the best available information on May 22, 2024.

A non-binding good faith estimated cost and time to construct the Network Upgrades required to interconnect the proposed project will be provided in a separate letter to the IC.



Contents

Executive Summary	vii
1 Introduction	1
2 Purpose and Scopes of Study	4
3 Standard and Criteria	5
4 Assumptions and Conditions	6
5 System Studies and Results	7
5.1 Power Flow Study Results	7
5.1.1 Branch Loading Analysis	8
5.1.2 Steady-State Voltage Performance	9
5.1.3 Reactive Power Capability Evaluation	10
5.1.4 Anti-Islanding	10
5.2 Fault Analysis	10
5.3 Stations Requirements	10
5.4 Protection & Control Requirements	11
5.5 Telecommunications Requirements	12
6 Cost Estimate and Schedule	13
7 Conclusions	14

Appendices

Appendix A	One-Line Sketch for New Switching Station
Appendix B	BC Hydro Report - K2 Wind Project Interconnection Feasibility Study Power Flow Analysis Results

Acronyms

The following are acronyms used in this report.

BCH	BC Hydro
CEAP	Competitive Electricity Acquisition Process
COD	Commercial Operation Date
DTT	Direct Transfer Trip
ERIS	Energy Resource Interconnection Service
FeS	Feasibility Study
IBR	Inverter-Based Resources
IC	Interconnection Customer
MPO	Maximum Power Output
NERC	North American Electric Reliability Corporation
NRIS	Network Resource Interconnection Service
OATT	Open Access Transmission Tariff
POI	Point of Interconnection
RAS	Remedial Action Scheme
TIR	BC Hydro “60 kV to 500 kV Technical Interconnection Requirements for Power Generators”
WECC	Western Electricity Coordinating Council
WTG	Wind Turbine Generator
EDM	Edmonds Office
FVO	Fraser Valley Office
SIC	South Interior Control
SIO	South Interior Office

1 Introduction

*Note: The power flow study results and conclusions included in this report is based on the **BC Hydro Report - K2 Wind Project Interconnection Feasibility Study Power Flow Analysis Results**, which is included in the Appendix B. The content of Section 1 is reproduced here from the Appendix B for reader's convenience.*

Table 1-1 below summarizes the project reviewed in this Feasibility Study.

Table 1-1 Summary of Project Information

Project Name	K2 Wind Project	
Name of Interconnection Customer (IC)	[REDACTED]	
Point of Interconnection (POI)	on 1L244 at 39 km from NIC	
IC's Proposed COD	1st October 2029	
Type of Interconnection Service	NRIS <input checked="" type="checkbox"/>	ERIS <input type="checkbox"/>
Maximum Power Injection ¹ (MW)	155 MW (Summer)	155 MW (Winter)
Number of Generator Units	28 x 5.7 MW WTGs	
Plant Fuel	Wind	
Note 1: The maximum achievable power injection at the POI is approx. 155 MW after accounting for MW losses and service load which is lower than the IC proposed 160 MW.		

[REDACTED] the interconnection customer (IC), requests to interconnect its K2 Wind Project (2024 CEAP IR # 18) to the BC Hydro system. K2 Wind Project has twenty-eight (28) [REDACTED] type-3 wind turbine generators with total installed capacity of 159.6 MW. The IC's proposed Point of Interconnection (POI) is on BC Hydro's 138 kV line 1L244, approx. 39 km from Nicola substation (NIC). The IC's project will connect to the POI via a 5 km 138 kV interconnection line. The proposed commercial operation date (COD) is Oct 1, 2029.

Figure 1-1 shows the Nicola-Highland region transmission system diagram. Nicola substation (NIC) is a major substation in this area with two existing 500/230 kV transformers (NIC T2 & T3) and two 230/138 kV transformers (NIC T5 & T6). NIC presently supplies three 138 kV transmission lines — 1L251 to the Copper Mountain Mine (BC) Ltd.'s Copper Mountain substation (CUM) and Similco

substation (SCO), 1L243 to BC Hydro's Highland substation (HLD) and 1L244 to BC Hydro's Westbank substation (WBK).

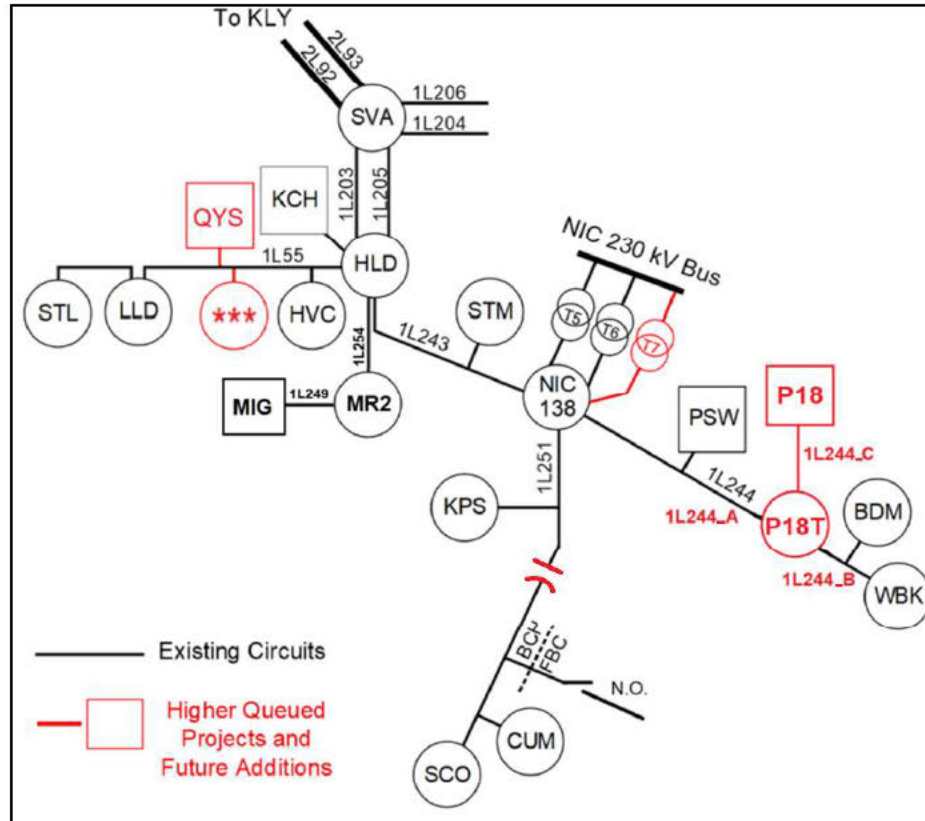

Figure 1-1: Nicola-Highland region 138/230 kV Transmission System Diagram

The existing line 1L244 is a radial circuit that mainly supplies WBK. There are two existing customers' facilities tap-connected on the line – Pennask-Shinish Wind Farm (PSW) and Brenda Mines Substation (BDM). PSW is an IPP wind farm with total capacity of 30 MW.

In addition to PSW, there are three other customers' owned power plants in the study region.

- Kwoiek Creek Generating Station (KCH) has a total capacity of 60 MW and is connected to HLD via the line 1L57.
- Merritt Green Energy Project Generating Station (MIG) has a total capacity of 40 MW and is connected to Merritt 2 Substation (MR2) via 1L249.

- quA-ymn Solar farm (QYS) is a 15 MW IPP generating project currently under construction. It is connected to 1L55 via a tap.

There are several high-queued load interconnections and their associated network upgrades in the study area. The relevant network upgrades being planned in the study region are as follows.

- Nicola Substation Transformation Capacity Reinforcement: this project will add a new 230 kV/138 kV transformer at NIC (i.e. NIC T7) to mitigate the possible transformer overload associated with the industrial load increase in Highland region.
- 1L243 reconductoring: this line rating upgrade is required to accommodate an industrial load increase in Highland region.
- 1L251 series capacitor project: Line 1L251 will be series compensated to accommodate an industrial load increase on 1L251.

2 Purpose and Scopes of Study

This Feasibility Study is a preliminary evaluation of the system impact of interconnecting the proposed project to the BC Hydro system based on power flow and short circuit analysis in accordance with BCH's Open Access Transmission Tariff (OATT). A non-binding good faith estimated cost of required Network Upgrades and estimated time to construct will be provided.

Per OATT, the feasibility study is performed individually for each of the participating projects in the CEAP process and focuses specifically on the BC Hydro regional transmission system where the proposed generating project is proposed to be constructed. An assessment of the incremental effect on the 500kV bulk transmission system is beyond this study scope.

This is a "limited scope" study which is restricted to power flow studies of P0, P1, and P2 planning events as defined in TPL-001-4 Table 1 and short circuit analysis. The study does not address other technical aspects such as transient stability and switching transients and impact of multiple contingencies. These subjects would be addressed in subsequent System Impact Study if the project is a Successful Participant of the CEAP.

In case impact to the adjacent external systems to BC Hydro is observed, such impact would be addressed in subsequent detailed and coordinated studies with the relevant adjacent entities if the proposed interconnection proceeds further.

3 Standard and Criteria

The Feasibility Study is performed in compliance with the North American Electric Reliability Corporation (NERC) and Western Electricity Coordinating Council (WECC) reliability standards, and the BCH interconnection requirements in the TIR, and upon the ratings of the existing BCH transmission facilities described in Operating Orders, specifically:

- NERC standards: TPL-001-4 and FAC-002-3 relevant to the scope of this Feasibility Study.
- WECC criteria TPL-001-WECC-CRT-4 Transmission System Planning Performance, July 1, 2023.
- BC Hydro's 60 kV to 500 kV Technical Interconnection Requirements for Power Generators.
- BC Hydro Operating Order 5T-10, Ratings for All Transmission Circuits 60 kV or Higher, April 16, 2024.
- BC Hydro Operating Order 5T-14, Ratings for All Transmission and Distribution Transformer, November 8, 2022.
- BC Hydro System Operating Order 7T-22 System Voltage Control, September 19, 2023.

4 Assumptions and Conditions

*Note: The power flow study results and conclusions included in this report is based on the **BC Hydro Report - K2 Wind Project Interconnection Feasibility Study Power Flow Analysis Results**, which is included in the Appendix B. The study assumptions of the power flow studies were included in the Section 4 of the report in Appendix B and reproduced here for reader's convenience.*

This Feasibility Study is performed based on the IC's submitted data and information available to BC Hydro on May 22, 2024 for the study purpose. Appendix A shows the plant single line diagram for the IC's project used in the study model. Certain assumptions were, as set out below, made to the extent required.

The power flow study cases used in this Feasibility Study are established based upon the BC Hydro's base resource plan and load forecasts available at the time of performing the study, which includes existing and future generations, transmission facilities, and loads in addition to the subject interconnection project in this study. Applicable seasonal conditions and the appropriate study years for the study planning horizon are also incorporated.

Additional assumptions are listed as follows.

- 1) The regional generation are dispatched to the patterns that stress the transmission system in the study area. In these patterns, the regional generations are typically set to their Maximum Power Outputs (MPO) unless otherwise specified.
- 2) West Kelowna Transmission Project (WKTP) is not included in the Feasibility Study model, as the project scope is undetermined at the time of performing this study.
- 3) For the purpose of performing this study, Nicola Substation Transformation Capacity Reinforcement project (i.e. addition of NIC T7) and 1L243 reconductoring is assumed completed by the time the IC's generating project enters service.
- 4) 1L243 after reconductoring is assumed to have a conductor rating of 1145 A (summer) and 1388 A (winter).

5 System Studies and Results

*Note: The power flow study results and conclusions included in this report is based on the **BC Hydro Report - K2 Wind Project Interconnection Feasibility Study Power Flow Analysis Results**, which is included in the Appendix B. The content of Section 5.1 is reproduced here from the Appendix B for reader's convenience. Please refer to the Appendix B for more details on the power flow study results and conclusion.*

Based upon the IC's submitted information and the area system conditions, a new switching station (referred to as "P18T") at the proposed POI on 1L244 is required to interconnect the IC's generating project to the BCH system. There are multiple terminals and multiple sources on the existing line 1L244. The addition of the new switching station would help to maintain reliability and adequate protection performance to serve the existing customers and the new addition.

With the new switching station P18T, the existing line 1L244 will be segregated into three new lines, temporarily referred to as: 1L244_A (NIC-P18T), 1L244_B (P18T-WBK) and 1L244_C (P18T-P18). The temporary line designations will be replaced by permanent designations at a later stage of interconnection study.

The existing line 1L244 does not meet BES criteria and is excluded from the Bulk Electric System (BES) list. The line 1L244_A (NIC-P18T) will become part of BC Hydro BES and need to be compliant with applicable MRS requirements. The line 1L244_B will remain as a non-BES line.¹

5.1 Power Flow Study Results

Power flow studies were performed to evaluate whether the IC's generating project would cause any unacceptable system performance (e.g. equipment overloads, steady-state voltage violation and voltage instability) and to determine the reinforcement requirement based on steady state performance analysis.

The study focuses on the 2030 light summer (30LS) system condition which is typically a stressed condition for a generation interconnection project, taking into

¹ Conclusion of line 1L244_C in BC Hydro BES is removed from this report as it will be part of Generator Owner asset. This is the change made after K2 Wind Project Interconnection Feasibility Study Power Flow Analysis Results which was prepared by [REDACTED] on June 28, 2024.

considerations of factors such as load conditions, seasons and generation patterns. The 2030 heavy summer (30HS) and 2029 heavy winter (29HW) cases are also checked at a high level to capture any possibility of performance violations under heavy load scenarios.

5.1.1 Branch Loading Analysis

Table 5-1 shows a summary of branch loading analysis under system normal and single contingencies (P1, P2) for the load conditions studied (30LS, 30HS, 29HW).

The study finds no transformer or line overload under system normal conditions for the load conditions studied. For single contingencies, the connection of the K2 Wind Project causes a line overload in the summer load conditions (30HS & 30LS). In summer conditions with high outputs from PSW and the IC's project, part of the new line 1L244_A (NIC to PSW tap) could be loaded up to 110% of its normal rating following the 1L244_B contingency. Similarly, other contingencies that results in the entire loss of WBK load (such as WBK T1 fault or WBK 1CB4 fault) may also result in the 1L244_A overload.

A generator shedding or runback signal from NIC is required to address the 1L244_A overload under contingencies. If an overload on 1L244_A is detected, a signal will be initiated from NIC to shed or run back generation at the IC's facility. The overload detection mechanism and exact mitigation actions will be determined in discussion with BCH at the next study stage.

In addition to the base generation pattern, a sensitivity case with low generation in the Highland region (MIG, KCH, QYS) is checked to stress the 138 kV line 1L243 from NIC to HLD. Tripping of 5L87 is the most severe contingency for this scenario, resulting in a higher flow on 1L243 from NIC to HLD. 1L243 line rating is found adequate to accommodate high flows under the sensitivity case.

Table 5-1: Summary of Branch Loading Analysis Results

Case	IC's Plant Output	Contingency		Branch Loading		
				1L244_A	1L244_A	NIC T5
		Cat.	Description	NIC-PSW tap	PSW tap-P57T	
Winter Rating				220 MVA	220 MVA	287 MVA
29HW	Max	P0	System Normal	50%	36%	5%
	Max	P1	NIC T6	50%	36%	7%
Summer Rating				169.7 MVA	169.7 MVA	287 MVA
30HS	Max	P0	System Normal	58%	43%	6%
	Max	P1	NIC T6	58%	43%	8%
	Max	P1	1L244 B	109%	94%	8%
30LS	Max	P0	System Normal	88%	70%	6%
	Max	P1	1L244_B	110%	93%	9%
	Max	P1	1L251	87%	70%	11%

5.1.2 Steady-State Voltage Performance

Table 5-2 shows a summary of steady-state voltage performance under various system conditions and contingencies. With the connection of the IC's project, the steady-state voltage performance under system normal and single contingency condition is acceptable for all the studied load conditions.

West Bank substation (WBK) is a summer peaking substation and the line flow on line 1L244 is highest in the heavy summer condition. In 30HS case, the single contingency that leads to the worse voltage performance is NIC 500 kV Circuit Breaker fault (e.g. NIC 5CB11). No voltage violation is observed for these contingencies. The study also finds that K2 Wind Project could improve the load bus voltage at WBK under heavy load conditions.

Table 5-2: Summary of Steady-State Voltage Study Results

Case	IC's Plant Output	Contingency		Bus Voltage (PU)		
				NIC 138	WBK 138	P18T 138
		Cat.	Description			
29HW	Max	P0	system normal	1.02	0.99	1.01
30HS	Max	P0	system normal	1.02	0.97	1.01
	0 MW	P0	system normal	1.02	0.97	1.01
	0 MW	P2.3	NIC 5CB11	1.02	0.97	1.01
30LS	Max	P0	system normal	1.02	1.00	1.01
	0 MW	P0	system normal	1.02	1.00	1.01

5.1.3 Reactive Power Capability Evaluation

The BC Hydro TIR requires IBR power plant to have the dynamic reactive power capability at a minimum of +/- 33% of its MPO at the high voltage side of the IC's switchyard over the full MW operating range.

Based on the PSS/E power flow data submitted by the IC, the proposed generating project would be capable to meet the BC Hydro's reactive capability requirement, which is subjected to further verification at the next stage of interconnection study.

Furthermore, the BCH TIR requires the IC's project to provide sufficient reactive power capability over full MW operating range including at zero MW output level. According to the IC-provided reactive capability curve, the proposed WTG has +/- 3.0 Mvar reactive capability at zero MW output, which needs to be re-confirmed if the IC's project proceeds further.

5.1.4 Anti-Islanding

If 1L244_A between NIC and P18T is open at either end, the IC's project may be inadvertently islanded with the existing generators and BC Hydro loads, which is not allowed. A direct transfer trip (DTT) from NIC to P18T is required to isolate the wind farm for protective and unintentional tripping of 1L244_A.

In addition, the IC is required to install anti-islanding protection within its facility to disconnect the IC's wind farm from the grid when an inadvertent island with the local load forms.

5.2 Fault Analysis

The short circuit analysis in the FeS is based upon the latest BC Hydro system model, which includes the generating facility information and associated impedance data provided by the IC. A more detailed study will be performed at the system impact study stage if needed.

5.3 Stations Requirements

A new outdoor 138 kV, 3-circuit breaker ring bus switching substation (P18T temporarily) will be built at the proposed POI, close to the existing 138 kV transmission line 1L244. The existing transmission line 1L244 will be cut and

looped in to, and 138 kV line of K2 Wind Project (1L244_C) will be terminated at the new substation.

The station scope of work at the new switching station P18T is as follows.

- Acquire adequate property for a new substation close to the existing transmission line 1L244.
- Construct a new outdoor 138 kV, 3-circuit breaker ring bus switching substation. Refer to the one-line Sketch in Appendix A for details.

Note:

- The designations of the new station, the new line connecting to the customer and the two new lines derived from 1L244 will be assigned in later stage.
- The Installation location of the metering kits will be decided in later stage.

5.4 Protection & Control Requirements

BC Hydro will provide line protections 1L244_A (NIC-P18T), 1L244_B (P18T-WBK) and 1L244_C (P18T-P18) (BC Hydro end only) protections. As part of the line protection replacements for each of the three lines, telecommunication facilities will be required to accommodate the new protection schemes.

The IC is to provide the following for the interconnection of K2 wind project:

- Entrance protection that complies with the latest version of the “60 kV to 500 kV BC Hydro Technical Interconnection Requirements for Power Generators.”
- Provide two SEL-411L-1 relays (firmware and options specified by BC Hydro) at the entrance of P18 to provide protection coverage for 1L244_C. BC Hydro P&C Planning will provide core protection settings for these relays to protect transmission line 1L244_C during a transmission line fault. Non-core protection such as local breaker failure, auto-reclosing, backup protection for station elements will not be provided by BC Hydro P&C Planning.
- The IC is responsible for NERC PRC-related tasks, settings to compliance standards within their facilities.
- The IC is responsible for providing a communications link for remote interrogation of the PPIS equipment by BCH servers.

- Provide anti-islanding protection as stated in Section 5.1.

The runback schemes or RAS requirements stated in Section 5.1 are mainly to address the overloading concerns under contingencies, which are preliminary. These RAS requirements may utilize the communication channels required for protection purposes included in the cost estimate. If the proposed project proceeds through the CEAP process, subsequent System Impact Studies may identify additional RAS requirements for this interconnection. These RAS functional requirements will include initiating events, control actions, and latency times. Depending on these supplementary requirements, additional telecommunication facilities may be needed to facilitate signal transmission between the BC Hydro substations and customer facilities.

5.5 Telecommunications Requirements

BC Hydro performed a high-level feasibility assessment of a telecom solution to meet the following requirements.

Teleprotection Requirements for Telecom

- WECC Level 3 PY & SY, NIC – P18T, with C37.94 interfaces.
- WECC Level 3 PY & SY, P18T – P18, with C37.94 interfaces.
- WECC Level 3 PY & SY, P18T – PSW, with C37.94 interfaces.

Telecontrol Requirements for Telecom

- One P18 SCADA circuit off SIC.
- Two P18T SCADA circuits off FVO & SIO.
- One P18T REMACC circuit off EDM.

Other Requirements for Telecom

- None identified.

Certain assumptions were made for determining a potential telecom solution. Details of the telecom solution (e.g. assumptions made, alternatives investigated and work required for BCH and the IC) would be provided at the next study stage.

6 Cost Estimate and Schedule

The non-binding good faith estimated cost and time to construct the Network Upgrades required to interconnect the proposed project will be provided in a separate letter to the IC.

7 Conclusions

To interconnect the K2 Wind Project and its facilities to the BCH Transmission System at the POI, this Feasibility Study has identified the following conclusions and requirements:

1. A new 138 kV switching station (referred to as “P18T”) on 1L244 is required at the proposed POI for interconnecting the IC’s generating project to the BCH system.
2. The connection of K2 Wind Project does not cause any performance violation (i.e. thermal overload, voltage performance violation or voltage stability concern) under system normal conditions.
3. The connection of K2 Wind Project will cause an overload on 1L244_A (NIC-PSW tap) under single contingencies. If an overload on 1L244_A is detected, a signal from NIC will be initiated to shed or run back generation at the IC’s facility. The overload detection mechanism and exact mitigation actions will be determined in discussion with BCH at the next study stage.
4. A direct transfer trip (DTT) from NIC to P18T is required to isolate the wind farm for protective and unintentional tripping of 1L244_A. In addition, the IC is required to install anti-islanding protection within their facility to disconnect the IC’s wind farm from the grid when an inadvertent island with the local loads forms.
5. According to BC Hydro’s TIR, the IC’s project must have sufficient reactive power capability over full MW operating range including at the zero MW output level. The K2 wind farm as submitted does not meet the reactive capability requirement at zero MW output level, which will need to be addressed.
6. The line 1L244_A will become part of BC Hydro BES and need to be compliant with applicable NERC MRS requirements. The line 1L244_B (P18T-WBK) will remain as a non-BES line.
7. BC Hydro will provide line protections for 1L244_A, 1L244_B and 1L244_C (BC Hydro end only). As part of the line protection replacements for each of the three lines, telecommunication facilities will be required to accommodate the new protection schemes. The IC shall provide required

relays, telecom facility and associated equipment at its facilities to accommodate the new protection schemes.

Appendix A One-Line Sketch for New Switching Station

Figure A-1 shows the Stations Planning One-Line Sketch for the New Switching Station P18T. Temporary line designations 1L244A and 1L244B corresponds to 1L244_A and 1L244_B in Figure 1-1, respectively.

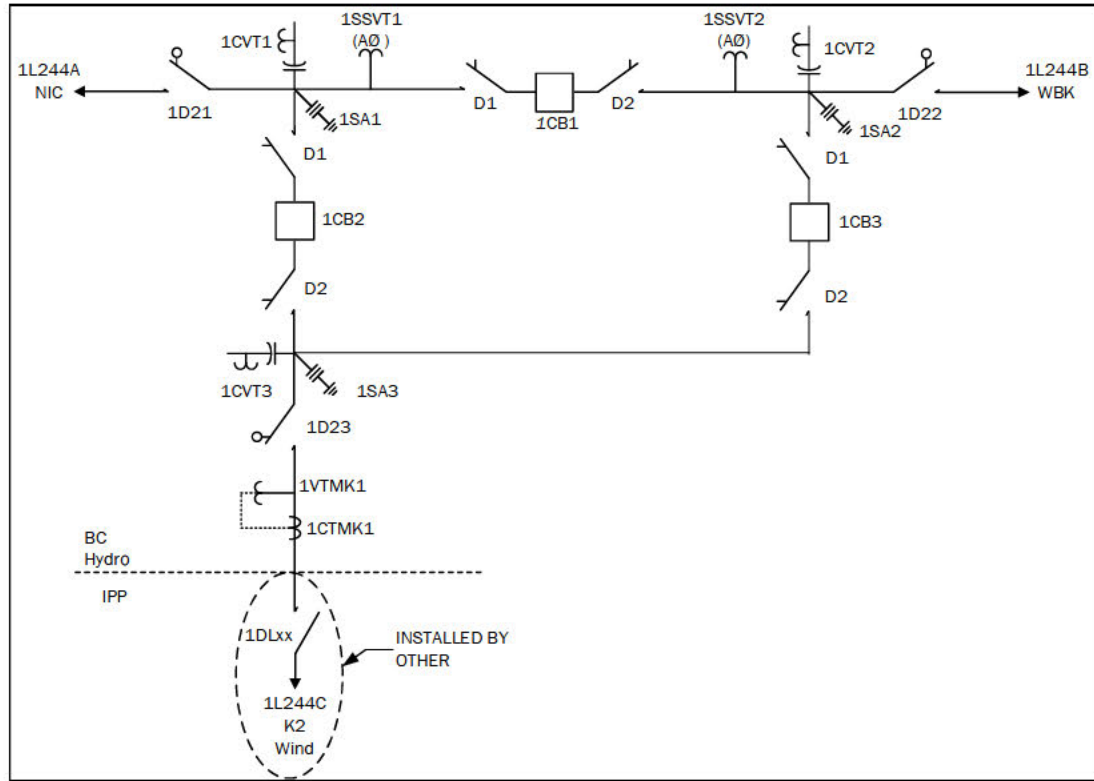

Figure A-1: Stations Planning One-Line Sketch for the New Switching Station P18T.

Appendix B BC Hydro Report - K2 Wind Project Interconnection Feasibility Study Power Flow Analysis Results



CEAP2024_IR_18_K2
_Wind_FeS_Report_