

6911 Southpoint Drive (B03)  
Burnaby, BC  
V3N 4X8

December 17, 2025

[REDACTED]

via email: [REDACTED]

**RE: CEAP IR #58 – [REDACTED] – Interconnection Feasibility Study**

Dear [REDACTED]:

Enclosed is the Interconnection Feasibility Study for the proposed Interconnection Request (IR), [REDACTED], submitted under Attachment M-2: Transmission Service and Interconnection Service Procedures for Competitive Electricity Acquisition Process (CEAP) of the Open Access Transmission Tariff (OATT). This letter provides a non-binding good faith estimate of the cost and time to construct the facilities required to interconnect your project to BC Hydro's Transmission System, being the Network Upgrades, based on the findings of the Interconnection Feasibility Study.

### **Open Access Transmission Tariff**

The OATT defines Network Upgrades as additions, modifications, and upgrades to BC Hydro's Transmission System required at or beyond the Point of Interconnection (POI) to accommodate the interconnection of the Generating Facility to the BC Hydro's Transmission System. Pursuant to the OATT, BC Hydro will design, procure, construct, install, and own the Network Upgrades. While BC Hydro will pay the costs for the Network Upgrades, the Interconnection Customer provides security for such costs.

### **Interconnection Study Costs**

The Interconnection Customer is responsible for paying the full cost of all Interconnection Studies in cash. Interconnection Study costs vary depending on the scope, complexity, and other factors such as whether any scope is shared with another Interconnection Customer (not applicable to this Interconnection Feasibility Study). The deposit amounts specified in the OATT are not proxy Interconnection Study costs. If actual Interconnection Study costs exceed the deposit amount, the Interconnection Customer must pay the remaining balance in cash. Please refer to the answer for question no. 53 in the posted [Questions & Answers for 2025 Call for Power](#) for typical study cost ranges.

### **Cost Estimate**

Based on the Interconnection Feasibility Study, the non-binding good faith estimated cost (typical accuracy range of +150%/-50%) for Network Upgrades required to interconnect your project is \$59.0 M.

### **Major Scope of Work Identified:**

- Supply and install one motor-operated disconnect switch, one 12 kV circuit breaker, and one 12 kV, 75 MVAR switched shunt reactor with AutoVar control scheme at the tertiary winding of the T1 transformer of the 230 kV bus at Kennedy substation (KDS)

- Upgrade required substation facilities, infrastructures, and bus work to support new station equipment
- Supply and install required Protection, Control and Telecommunications equipment

**Exclusions:**

- GST
- Permits
- Right-of-Way & property costs

**Key Assumptions:**

- Construction by contractor
- 12 months of construction is considered
- No construction during winter season
- Execution of early Engineering and Procurement Agreement
- Impact Benefit Agreements with First Nations are not considered
- No station or control room expansion

**Key Risks:**

- Major equipment delivery presents potential project cost and schedule risks, based on variance in equipment lead times
- If station or control room expansion is required, it may present project cost and schedule risks
- No defined supply chain strategy; construction costs may increase depending on delivery method
- Project schedule may be longer than expected, leading to increased overhead costs
- Ground improvements may be required leading to increased construction costs
- Contaminated soil may be encountered leading to increased construction costs
- Cost of materials and major equipment may be affected by market conditions and escalation

**Indirect Interconnection**

Your IR involves an indirect interconnection to the BC Hydro Transmission System. Under the OATT Attachment M-1: Standard Generator Interconnection Procedures (SGIP) and the Standard Generator Interconnection Agreement (SGIA), the party executing the SGIA must be the owner of the Interconnection Customer Interconnection Facilities up to the POI. Depending on the scope of required Network Upgrades, this execution may occur years before the Commercial Operation Date.

**Study Limitations and Exclusions**

***Protection, Control, and Telecommunications***

The Interconnection Feasibility Study does not include a detailed review of the protection, control, and telecommunications system requirements specific to your Interconnection Request. Based on a high-level review, we have identified proxy costs for protection, control, and telecom Network Upgrades drawn from comparable interconnection projects with similar scope and complexity; these proxy costs have been included solely for indicative budgeting purposes. The relative interconnection cost determined by the Interconnection Feasibility Study includes a telecommunications component based on an assumed solution to deliver teleprotection and telecontrol circuit requirements necessary for the Interconnection Request.

Protection, control, and telecommunications system requirements will be reviewed in detail in the System Impact Study if you are a successful participant of the CEAP and meet applicable requirements.

For Interconnection Feasibility Study purposes, it is assumed that any applicant-proposed works that could obstruct or impair the performance of existing BC Hydro microwave systems or new links from the proposed ICIF to the BC Hydro microwave system would be identified and either relocated or repositioned as determined in a System Impact Study if you are a successful participant of the CEAP and meet applicable requirements. Such works may include, but are not limited to, towers, turbines, dams, support structures, panels, surface materials deposited or redistributed, water surface changes, or vegetation.

It is also assumed that there will be some telecom telecommunications system requirements and associated costs that fall under the Interconnection Customer Interconnection Facilities (ICIF) that is not included in the estimated cost for Network Upgrades.

### ***Generation Shedding/Curtailment Scheme and Electromagnetic Transient (EMT) Studies***

The generation shedding/curtailment scheme reviews (e.g., Remedial Action Scheme (RAS), and a direct transfer trip for anti-islanding scheme) and EMT studies are completed in a System Impact Study. The outcomes of these studies may result in additional requirements, which could include Network Upgrades or ICIF. Any costs associated with completion of these studies, and resulting requirements, are not included in the Interconnection Feasibility Study cost estimate.

### ***Revenue Metering***

Please note that revenue metering requirements have not been determined with the Interconnection Feasibility Study. As such, any costs associated with revenue metering and other interconnection components are not included in the cost estimate provided above. Once these requirements are defined, costs that are attributable to the Interconnection Customer are to be paid in cash. For more details on revenue metering requirements and responsibilities, please refer to:

<https://www.bchydro.com/content/dam/BCHydro/customer-portal/documents/distribution/standards/ds-rmr-complex-revenue-metering.pdf>.

### **Schedule**

Based on the Interconnection Feasibility Study, the non-binding good faith estimated in-service date for your Interconnection Request's Network Upgrades is Quarter 3 2030 (calendar year). To achieve this timeline, we may need to expedite certain activities, including engineering design and procurement of long-lead equipment.

Timely actions required from you to minimize risks to the schedule:

- Submission of additional technical data required for the System Impact Study and Facilities Study
- Submission of any required information or document such as demonstration of Site Control
- Execution of Combined Study Agreement and Standard Generator Interconnection Agreement
- Financial commitments and securities

Please note that changes to your Interconnection Request or delays in data submission or financial commitments may also impact the target in-service date.

If you have any questions, please contact the BC Hydro CEAP team at [ceap2025@bchydro.com](mailto:ceap2025@bchydro.com).

Sincerely,

[Redacted signature block]

[Redacted name]

Manager, Customer Interconnections

BC Hydro

Encl.: CEAP\_2025\_IR58\_ [Redacted] Feasibility\_Study.pdf

  
**Interconnection Feasibility Study**

**BC Hydro EGBC Permit to Practice No: 1002449**

**2025 CEAP IR #58**

Prepared for:



Prepared by:

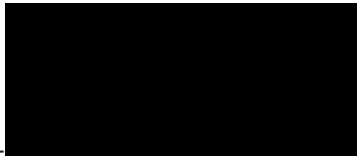

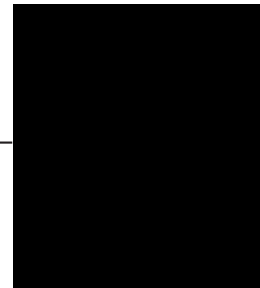

  
Specialist Engineer, Transmission

Reviewed by:



Technical Strategic Principle, Transmission

Accepted by:

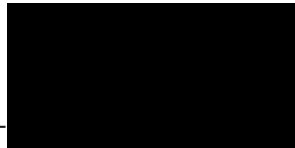

Division Manager, Transmission Planning

## Report Metadata

Header: 2025 CEAP IR #58  
Subheader: Interconnection Feasibility Study  
Title: [REDACTED]

Subtitle: 2025 CEAP IR #58  
Report Number: 850-APR-00015  
Revision: 0  
Confidentiality: Public  
Date: 2025 Dec 05  
Volume: 1 of 1

Prepared for: [REDACTED]  
Prepared by: [REDACTED]  
Title: Specialist Engineer, Transmission Planning  
Checked by: N/A  
Title: N/A  
Reviewed by: [REDACTED]  
Title: Technical Strategic Principle, Transmission Planning

Related Facilities: 2L320, KDS, P58, KMI  
Additional Metadata: Transmission Planning 2025-135  
Filing Subcode 1350

## Revisions

| Revision | Date     | Description     |
|----------|----------|-----------------|
| 0        | 2025 Dec | Initial release |

## Disclaimer of Warranty, Limitation of Liability

This report was prepared solely for internal purposes. All parties other than BC Hydro are third parties.

BC Hydro does not represent, guarantee or warrant to any third party, either expressly or by implication: any information, product or process disclosed, described or recommended in this report.

BC Hydro does not accept any liability of any kind arising in any way out of the use by a third party of any information, product or process disclosed, described or recommended in this report, nor does BC Hydro accept any liability arising out of reliance by a third party upon any information, statements or recommendations contained in this report. Should third parties use or rely on any information, product or process disclosed, described or recommended in this report, they do so entirely at their own risk.

This report was prepared by the British Columbia Hydro And Power Authority ("BCH") or, as the case may be, on behalf of BCH by persons or entities including, without limitation, persons or entities who are or were employees, agents, consultants, contractors, subcontractors, professional advisers or representatives of, or to, BCH (individually and collectively, "BCH Personnel").

This report is to be read in the context of the methodology, procedures and techniques used, BCH's or BCH's Personnel's assumptions, and the circumstances and constraints under which BCH's mandate to prepare this report was performed. This report is written solely for the purpose expressly stated in this report, and for the sole and exclusive benefit of the person or entity who directly engaged BCH to prepare this report. Accordingly, this report is suitable only for such purpose, and is subject to any changes arising after the date of this report. This report is meant to be read as a whole, and accordingly no section or part of it should be read or relied upon out of context.

Unless otherwise expressly agreed by BCH:

- (a) any assumption, data or information (whether embodied in tangible or electronic form) supplied by, or gathered from, any source (including, without limitation, any consultant, contractor or subcontractor, testing laboratory and equipment suppliers, etc.) upon which BCH's opinion or conclusion as set out in this report is based (individually and collectively, "Information") has not been verified by BCH or BCH's Personnel; BCH makes no representation as to its accuracy or completeness and disclaims all liability with respect to the Information;
- (b) except as expressly set out in this report, all terms, conditions, warranties, representations and statements (whether express, implied, written, oral, collateral, statutory or otherwise) are excluded to the maximum extent permitted by law and, to the extent they cannot be excluded, BCH disclaims all liability in relation to them to the maximum extent permitted by law;
- (c) BCH does not represent or warrant the accuracy, completeness, merchantability, fitness for purpose or usefulness of this report, or any information contained in this report, for use or consideration by any person or entity. In addition, BCH does not accept any liability arising out of reliance by a person or entity on this report, or any information contained in this report, or for any errors or omissions in this report. Any use, reliance or publication by any person or entity of this report or any part of it is at their own risk; and
- (d) In no event will BCH or BCH's Personnel be liable to any recipient of this report for any damage, loss, cost, expense, injury or other liability that arises out of or in connection with this report including, without limitation, any indirect, special, incidental, punitive or consequential loss, liability or damage of any kind.

## Copyright Notice

Copyright and all other intellectual property rights in, and to, this report are the property of, and are expressly reserved to, BCH. Without the prior written approval of BCH, no part of this report may be reproduced, used or distributed in any manner or form whatsoever.

## Contributors

The following accept responsibility for the content in the specified sections. Professionals apply their signature and/or seal as appropriate.

**Section:**

Entire report  
except listed  
below

**Discipline:**

Transmission Planning

Contributed by:

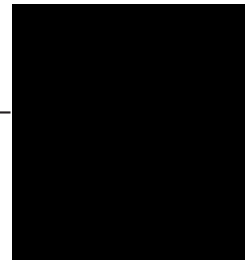

---

Specialist Engineer, Transmission  
Planning

**Section:**

5.2, 5.3

**Discipline:**

Stations Planning

Contributed by:

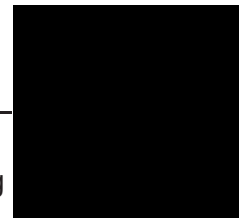

---

Specialist Engineer, Station Planning

## Executive Summary

██████████ the Interconnection Customer (IC), requests to interconnect its ██████████ wind project (2025 CEAP IR #58) to the BC Hydro (BCH) system. ██████████ has thirty (30) ██████████ type-3 wind turbine generators (WTG), adding a total installed capacity of 204 MW and maximum power injection of 188 MW into the BCH system. The IC proposes an indirect tap connection on 2L320, a third-party owned 230 kV transmission line, at approximately 113 km from Kennedy substation (KDS). 2L320 currently radially serves a Transmission Voltage Customer (TVC) at Kemess Mines substation (KMI). The Point of Interconnection (POI) for this study is the KDS 230 kV bus. The IC will construct a 230 kV transmission line, totalling approximately 20 km in length, connecting to the proposed tapping structure on 2L320.

The proposed Commercial Operation Date (COD) of this project is October 1, 2029.

During the data review phase of this Feasibility Study, the IC clarified that a new series capacitor, 50  $\Omega$  capacitive reactance, will be installed on 2L320 between the tap-point and KDS 230 kV bus, close to the tap-point end. This series capacitor was implicitly modelled into the impedance of 2L320 in the IC-submitted PSS/E model to BCH.

To interconnect ██████████ and its facilities to the BCH Transmission System at the proposed POI, this Feasibility Study has made the recommendations and conclusions as follows:

1. An indirect transmission tap connection on a third-party owned transmission line, 2L320, is acceptable for interconnecting the IC's generating project to the BCH system. However, the POI to the BCH system shall be considered at the KDS 230 kV bus.
2. The connection of ██████████ may contribute towards high voltage conditions on the 230 kV system when the generators are not online in System Normal operating condition. A 75 MVAR switched shunt reactor with AutoVAr control scheme connecting to the tertiary winding of the KDS T1 transformer is required to mitigate the high voltage concerns. The size and exact location of the reactor at the KDS substation will be explored in the later stages of the interconnection of this project.

3. For single contingency operating conditions, potential thermal overloads of 500 kV series capacitors at Kennedy Series Capacitor Station (KDY) and McLeese Series Capacitor Station (MLS) and 500 kV transmission lines are observed. These violations can be addressed by the existing GMS Area Gen Shedding remedial action scheme (RAS). The new wind generators at [REDACTED] may need to participate in the existing GMS Area Gen Shedding RAS. The RAS function scope will be specified in the System Impact Study (SIS), if the need for RAS is determined.
4. Connecting a large wind farm to a series-compensated transmission line may cause sub-synchronous interaction (SSI), a technical issue that could lead to instability. This shall be evaluated in a generator interconnection SIS if this project proceeds to the next stage of the interconnection process.
5. [REDACTED] is required to install anti-islanding protection within its facility to disconnect the IC's generating plant from the grid when an inadvertent island with the local loads forms. The anti-islanding protection shall be configured in the manner that does not compromise the required ride-through performance.
6. [REDACTED] would be islanded with the TVC or BCH loads for certain fault and no-fault contingencies at KDS. A Direct Transfer Trip (DTT) protection scheme is required to isolate the IC's wind project at the IC's entrance circuit breaker to avoid potential islanding operations with the existing loads.
7. [REDACTED] is required to have the dynamic reactive power capability at a minimum of +/- 33% of its MPO at the high voltage side of the IC's switchyard over the full MW operating range, per BCH's TIR Section 6.4.2. Based on the IC-submitted PSS/E model, the proposed [REDACTED] does not meet the reactive capability requirement above, which needs to be addressed if the project proceeds to the next stage of the interconnection process.
8. The "STATCOM option" for the proposed WTGs is required so that each turbine can provide reactive power capability at zero MW output. BCH recognizes that Type-3 WTGs with the STATCOM option have an inherent limitation—providing only partial reactive power capability during turbine standstill.

9. Fast Frequency Response (FFR), as per BCH TIR Section 6.4.5, is required at [REDACTED]. The proposed WTGs, when the FFR function is enabled, are expected to temporarily boost the MW output to limit the system frequency drop during a major frequency event. The FFR settings should be determined in coordination with BCH in the later stage of the interconnection process.

The above conclusions are made based on the IC's input data and study assumptions listed in Section 4, which represent the best available information on October 14, 2025.

A non-binding good faith cost for required network upgrades and estimated schedule for construction is included in a separate letter to the IC.

Please note that, this Feasibility Study report does not include the descriptions of Protection, Control, and Telecommunications requirements and the associated upgrade scopes; however, as discussed in Section 2 "Purpose and Scopes of Study", the associated cost implications are captured and delivered in the cover letter to the IC.

# Contents

|  |           |
|--|-----------|
| <b>Executive Summary</b>                   | <b>vi</b> |
| <b>1 Introduction</b>                      | <b>1</b>  |
| <b>2 Purpose and Scopes of Study</b>       | <b>4</b>  |
| <b>3 Standard and Criteria</b>             | <b>5</b>  |
| <b>4 Assumptions and Conditions</b>        | <b>6</b>  |
| <b>5 System Studies and Results</b>        | <b>7</b>  |
| 5.1 Power Flow Study Results               | 7         |
| 5.1.1 Thermal Overload Analysis            | 7         |
| 5.1.2 Steady-State Voltage Analysis        | 8         |
| 5.1.3 Reactive Power Capability Evaluation | 8         |
| 5.1.4 Anti-Islanding Requirements          | 8         |
| 5.1.5 Other Performance Requirements       | 9         |
| 5.2 Fault Analysis                         | 9         |
| 5.3 Stations Requirements                  | 9         |
| <b>6 Cost Estimate and Schedule</b>        | <b>10</b> |
| <b>7 Conclusions</b>                       | <b>11</b> |

## Appendices

|            |  |
|------------|--|
| Appendix A | Schematic Diagram of the IC's Project      |
| Appendix B | Power Flow Study Results                   |
| Appendix C | One-Line Sketch for Work at KDS Substation |

## Acronyms

The following are acronyms used in this report.

|      |  |
|------|--|
| BCH  | BC Hydro   |
| CEAP | Competitive Electricity Acquisition Process  |
| COD  | Commercial Operation Date  |
| DTT  | Direct Transfer Trip   |
| ERIS | Energy Resource Interconnection Service  |
| FeS  | Feasibility Study  |
| IBR  | Inverter-Based Resources   |
| IC   | Interconnection Customer   |
| IR   | Interconnection Request  |
| LAPS | Local Area Protection Schemes  |
| MPO  | Maximum Power Output   |
| NERC | North American Electric Reliability Corporation  |
| NRIS | Network Resource Interconnection Service   |
| OATT | Open Access Transmission Tariff  |
| POI  | Point of Interconnection   |
| RAS  | Remedial Action Scheme   |
| TIR  | BC Hydro “60 kV to 500 kV Technical Interconnection Requirements for Power Generators” |
| WECC | Western Electricity Coordinating Council   |
| WTG  | Wind Turbine Generator   |

# 1 Introduction

Table 1-1 below summarizes the project reviewed in this Feasibility Study.

Table 1-1 Summary of Project Information

|                                       |   |                               |
|---------------------------------------|---|-------------------------------|
| Project Name                          | [REDACTED]  |                               |
| Name of Interconnection Customer (IC) | [REDACTED]  |                               |
| Point of Interconnection (POI)        | Tap on 2L320 (third-party owned) at 113 km from KDS |                               |
| IC's Proposed COD                     | October 1, 2029                                     |                               |
| Type of Interconnection Service       | NRIS <input checked="" type="checkbox"/>            | ERIS <input type="checkbox"/> |
| Maximum Power Injection (MW)          | 188 MW (Summer)                                     | 188 MW (Winter)               |
| Number of Turbines                    | 30 x 6.8 MW WTGs                                    |                               |
| Plant Fuel                            | Wind  |                               |

CPD Peace Region Corp., the Interconnection Customer (IC), requests to interconnect its [REDACTED] wind project (2025 CEAP IR #58) to the BC Hydro (BCH) system. [REDACTED] has thirty (30) [REDACTED] type-3 wind turbine generators (WTG), adding a total installed capacity of 204 MW with a maximum power injection of 188 MW into the BCH system. A 34.5 kV collector system transmits the energy from the wind turbines to two on-site 34.5/230 kV transformers that are connected to the BCH system through IC-built 20 km long 230 kV line via an indirect tap on 2L320. 2L320 is a third-party owned 230 kV transmission line that radially serves a Transmission Voltage Customer (TVC) at Kemess Mines substation (KMI). The IC proposes to tap 2L320 at approximately 113 km from Kennedy substation (KDS). The Point of Interconnection (POI) for this study is the KDS 230 kV bus.

During the Data Review phase of the IR submission, the IC clarified that the TVC at KMI is under care and maintenance with minimum load assumed to be 0 MW, which results in maximum injection of 188 MW into the BCH system when the IBR Plant is generating at MPO. Also, the IC clarified that the IC will install a new series capacitor, 50 Ω capacitive reactance, on 2L320 between the tap-point and KDS 230 kV bus, close to the tap-point end. This series capacitor was implicitly modelled into the impedance of 2L320 in the IC-submitted PSS/E model to BCH.

Figure 1-1 shows the Mackenzie and Central Interior (CI) regional 138/230/500 kV transmission system diagram. The Mackenzie electric system is supplied via a single 500/230 kV transformer (three single phase units) at KDS. The 230 kV voltage level is stepped down to 138 kV via two transformers operated in parallel to further supply additional transmission and distribution customers. There is also an Independent Power Producer (IPP) in the region. The IC is interconnecting on 2L320 that radially supplies a TVC at KMI substation.

There are no existing branch overload or voltage stability concerns for single or multiple contingencies in the Mackenzie region. There is, however, the GMS Area Gen Shedding Remedial Action Scheme (RAS) that is relied on to secure the Northern Division 500 kV transmission system from which the Mackenzie region is supplied.

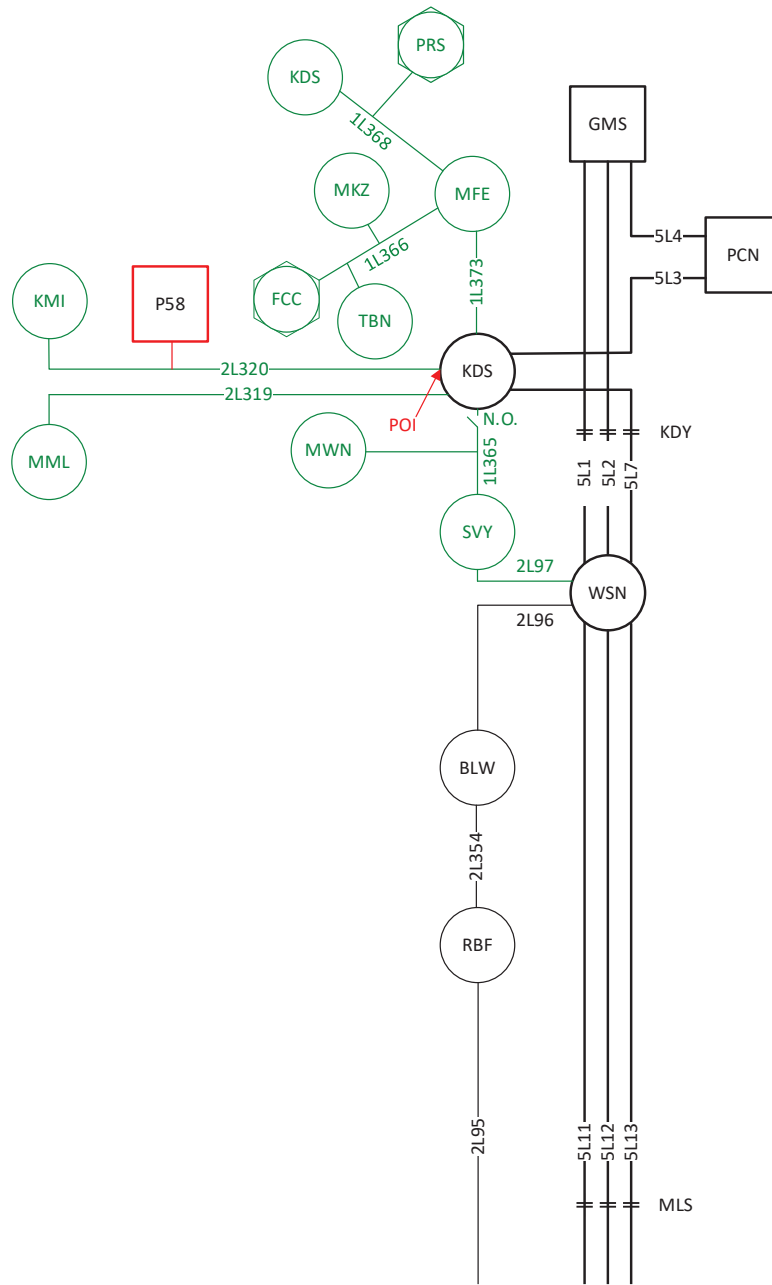

Figure 1-1: Mackenzie and CI Region 138/230/500 kV Transmission System Diagram with [REDACTED] and POI shown in red.

## 2 Purpose and Scopes of Study

This Feasibility Study is a preliminary evaluation of the system impact of interconnecting the proposed project to the BCH system based on power flow and short circuit analysis in accordance with BCH's Open Access Transmission Tariff (OATT) and produces the estimated cost of required network upgrades and the implementation schedule.

Per OATT, the Feasibility Study is performed individually for each of the participating projects in the CEAP process and focuses specifically on the BCH regional transmission system where the proposed generating project is connected and affects.

This is a "limited scope" study which is restricted to power flow studies of P0, P1 and P2 planning events as defined in TPL-001-4 and short circuit analysis. The study does not address other technical aspects such as transient stability and switching transients and impact of multiple contingencies. These subjects will be addressed in subsequent System Impact Study (SIS) if the project proceeds further. In addition, any potential impacts to the adjacent external systems to BCH would be addressed in subsequent detailed and coordinated studies with the relevant adjacent entities if the proposed generator project proceeds further.

Please note that, due to the compressed study timeline for 2025 CEAP Feasibility Studies, this report does not include the descriptions of the Protection, Control, and Telecommunication requirements and the associated upgrade scopes. Instead, the network upgrades associated with Protections, Controls and Telecommunications are incorporated with cost estimates in a separate cover letter to the IC.

### 3 Standard and Criteria

The Feasibility Study is performed in compliance with the North American Electric Reliability Corporation (NERC) and Western Electricity Coordinating Council (WECC) reliability standards, and the BCH interconnection requirements in the TIR, and upon the ratings of the existing BCH transmission facilities described in Operating Orders, specifically:

- NERC standards: TPL-001-4 and FAC-002-3 relevant to the scope of this Feasibility Study.
- WECC criteria TPL-001-WECC-CRT-4 Transmission System Planning Performance, July 1, 2023.
- BC Hydro's 60 kV to 500 kV Technical Interconnection Requirements for Power Generators, Rev 2.1.1, Effective: Sept 22, 2025.
- BC Hydro Operating Order 5T-10, Ratings for All Transmission Circuits 60 kV or Higher, Sept 17, 2025.
- BC Hydro Operating Order 5T-14, Ratings for All Transmission and Distribution Transformer, Sept 22, 2025.
- BC Hydro System Operating Order 7T-22 System Voltage Control, Sept 19, 2023.

## 4 Assumptions and Conditions

This Feasibility Study is performed based on the IC's submitted data and information available to BCH on October 14, 2025 for the study purpose. Assumptions are made wherever the IC's input is unavailable. Appendix A shows the schematic diagram of the IC's Project IC's project used in the study model.

The power flow study cases used in this Feasibility Study are established based upon BCH's base resource plan and load forecasts available at the time of performing the study, which includes existing and future generators, transmission facilities, and loads in addition to the subject interconnection project in this study. Applicable seasonal conditions and the appropriate study years for the study planning horizon are also incorporated. Additional assumptions are listed as follows.

- 1) The generation in the study area are dispatched to the patterns that stress the transmission system in the study area. In these patterns, the associated generators are typically set to their Maximum Power Outputs (MPO) unless otherwise specified.
- 2) 1L365 will be normal opened at KDS.
- 3) 2L320, the third-party owned transmission line, has sufficient capacity to accommodate the IC's wind project.

## 5 System Studies and Results

### 5.1 Power Flow Study Results

Power flow studies were performed to evaluate whether the IC's generating project would cause any unacceptable system performance (e.g. equipment overloads, steady-state voltage violation and voltage instability) and to determine the system reinforcement requirement based on steady state performance analysis.

The study focuses on the base scenario — 29HW/30HS/30LS — system conditions that include all the higher-queued generation projects in the region. These base cases were prepared based on factors such as load conditions, seasonal variation in ambient temperatures, and generation patterns that stress the transmission system.

The studies are performed for system normal conditions and under critical system contingencies specified in the P1 and P2 events by NERC Standard TPL-001-4. Study results are summarized below.

#### 5.1.1 Thermal Overload Analysis

The study shows that the addition of [REDACTED] would not cause thermal overloads under System Normal condition (P0).

For summer load conditions, overload of 500 kV series capacitors at Kennedy Series Capacitor Station (KDY) and 500 kV transmission lines is observed under single 500 kV contingencies in the GM Shrum (GMS)/Peace Canyon (PCN) – Williston (WSN) – Kelly Lake (KLY) corridor when [REDACTED] [REDACTED] interconnects. Additionally, in light summer conditions, overload on 500 kV series capacitors at McLeese Series Capacitor Station (MLS) is observed under single 500 kV contingencies in the WSN – KLY corridor following [REDACTED] interconnection. These overloads are mostly associated with the existing generation in the Peace Region. These overloads are addressed by the existing GMS Area Gen Shedding RAS.

The [REDACTED] wind project marginally contributes to these overloads and may need to participate in the existing generation shedding RAS, which will be determined in the SIS.

Appendix B contains the details of thermal overload analysis results.

### 5.1.2 Steady-State Voltage Analysis

With the connection of the IC's project, the steady-state voltage performance under system normal and single contingency conditions is acceptable for all heavy winter and summer conditions (30HS, 29HW).

However, for light summer condition (30LS), the IBR plant may contribute towards high voltage conditions on the 230 kV system when the generators are not online, but the plant remains connected to BCH system.

A 75 MVAR switched shunt reactor with AutoVAr control scheme at the tertiary winding of the KDS T1 transformer is required to address these overvoltage conditions. The size and exact location of the reactor at the KDS substation will be determined during the SIS stage.

Appendix B contains the details of steady-state voltage study results.

### 5.1.3 Reactive Power Capability Evaluation

The BCH TIR requires IBR power plant to have the dynamic reactive power capability at a minimum of +/- 33% of its MPO at the high voltage side of the IC's switchyard over the full MW operating range.

Based on the power flow model data submitted by the IC, the proposed [REDACTED] does not meet the requirements above, which needs to be addressed if the project proceeds to the next stage of the interconnection process.

In addition, according to the IC-provided reactive capability data, the proposed WTG would provide +1.7 MVAR to -1.7 MVAR reactive capability at the zero MW output if the turbine's "STATCOM" function is enabled. This function needs to be re-confirmed if the IC's project proceeds to next stage of the interconnection process.

### 5.1.4 Anti-Islanding Requirements

[REDACTED] is not arranged for islanded operation. In addition, the IC is required to install anti-islanding protection within its facility to disconnect the IC's wind farm from the grid when an inadvertent island with the local loads forms.

[REDACTED] would be islanded with the TVC loads or BCH loads for certain fault and no-fault contingencies at KDS. A Direct Transfer Trip (DTT) protection

scheme is required to isolate the IC's wind project at the IC's entrance circuit breaker to avoid potential islanding operations with the existing loads.

### **5.1.5 Other Performance Requirements**

Fast Frequency Response (FFR), as per BCH TIR Section 4.6.5, is required at the [REDACTED]. The proposed WTGs, when the FFR function is enabled, are expected to temporarily boost the MW output to limit the system frequency drop during a major frequency event. The FFR settings should be determined in coordination with BCH in the later stage of the interconnection process.

Connecting a large wind farm to a series-compensated transmission line may cause sub-synchronous interaction (SSI), a technical issue that could lead to instability. This shall be evaluated in a generator interconnection SIS if this project proceeds to the next stage of the interconnection process.

## **5.2 Fault Analysis**

The short circuit analysis in the FeS is based upon the latest BCH system model, which includes the generating facility information and associated impedance data provided by the IC. A more detailed study will be performed at the SIS stage if needed.

## **5.3 Stations Requirements**

It is assumed that a 75 MVar switched shunt reactor with AutoVAr control scheme connects at the 12 kV tertiary winding of the KDS T1 transformer. If the size or exact location of the reactor changes, the Station Scope of Work will also change.

The scope of work at the KDS substation is as follows.

- Add one 12 kV motor-operated disconnect switch, one 12 kV circuit breaker, and one 12 kV 75 MVar shunt reactor with AutoVAr control scheme at the tertiary winding of the existing KDS T1 transformer.
- Other associated station work including P&C, telecom, and SCADA.
- No station expansion is required for the above-mentioned facilities.

Refer to the one-line diagram in Appendix C for details.

## 6 Cost Estimate and Schedule

The non-binding good faith estimated cost and time to construct the network upgrades required to interconnect the proposed project will be provided in a separate letter to the IC.

## 7 Conclusions

To interconnect the [REDACTED] wind project and its facilities to the BCH Transmission System at the POI, this Feasibility Study has identified the following conclusions and requirements:

1. An indirect transmission tap connection on a third-party owned transmission line, 2L320, is acceptable for interconnecting the IC's generating project to the BCH system. However, the POI to the BCH system shall be considered at the KDS 230 kV bus.
2. The connection of [REDACTED] may contribute towards high voltage conditions on the 230 kV system when the generators are not online in System Normal operating condition. A 75 MVAR switched shunt reactor with AutoVAr control scheme connecting to the tertiary winding of the KDS T1 transformer is required to mitigate the high voltage concerns. The size and exact location of the reactor at the KDS substation will be explored in the later stages of the interconnection of this project.
3. For single contingency operating conditions, potential thermal overloads of 500 kV series capacitors at KDY and MLS and 500 kV transmission lines are observed. These violations can be addressed by the existing GMS Area Gen Shedding RAS. The new wind generators at [REDACTED] may need to participate in the existing GMS Area Gen Shedding RAS. The RAS function scope will be specified in the SIS, if the need for RAS is determined.
4. Connecting a large wind farm to a series-compensated transmission line may cause sub-synchronous interaction, a technical issue that could lead to instability. This shall be evaluated in a generator interconnection SIS if this project proceeds to the next stage of the interconnection process.
5. [REDACTED] is required to install anti-islanding protection within its facility to disconnect the IC's generating plant from the grid when an inadvertent island with the local load forms. The anti-islanding protection shall be configured in the manner that does not compromise the required ride-through performance.
6. [REDACTED] would be islanded with the TVC loads or BCH loads for certain fault and no-fault contingencies at KDS. A DTT protection

scheme is required to isolate the IC's wind project at the IC's entrance circuit breaker to avoid potential islanding operations with the existing loads.

7. [REDACTED] is required to have the dynamic reactive power capability at a minimum of +/- 33% of its MPO at the high voltage side of the IC's switchyard over the full MW operating range, per BCH's TIR Section 6.4.2. Based on the IC-submitted PSS/E model, the proposed [REDACTED] does not meet the reactive capability requirement above, which needs to be addressed if the project proceeds to the next stage of the interconnection process.
8. The "STATCOM option" for the proposed WTGs is required so that each turbine can provide reactive power capability at zero MW output. BCH recognizes that Type-3 WTGs with the STATCOM option have an inherent limitation—providing only partial reactive power capability during turbine standstill.
9. Fast Frequency Response (FFR), as per BCH TIR Section 6.4.5, is required at [REDACTED]. The proposed WTGs, when the FFR function is enabled, are expected to temporarily boost the MW output to limit the system frequency drop during a major frequency event. The FFR settings should be determined in coordination with BCH in a later stage of the interconnection process.



## Appendix B

### Power Flow Study Results

#### Base Scenario (29HW/30HS/30LS)

Table B-1: Thermal Overload Study Results

| Case                   | Peace Regional Generation (MW) | Contingency Identified |                  | Branch Loading (A/MVA/% of its seasonal normal rating) |               |               |            |
|------------------------|--------------------------------|------------------------|------------------|--|---------------|---------------|------------|
|                        |                                |                        |                  | 2L320  | KDY CX 500 kV | MLS CX 500 kV | KDS T1     |
|                        |                                |                        |                  | P58-KDS  |               |               | 230/500 kV |
| Winter Rating in MVA/A |                                |                        |                  | -  | 2300 A        | 1950 A        | 356 MVA    |
| 29HW                   | Max                            | P0                     | System Normal    | 498.30   | 1512.90       | 1114.90       | 100.80     |
|                        |                                |                        |                  | 71.00 %  | 65.80 %       | 57.20 %       | 28.30 %    |
|                        |                                | P1                     | 2L319 OOS        | 508.40   | 1585.10       | 1134.20       | 148.10     |
|                        |                                |                        |                  | 72.80  | 68.90         | 58.20         | 41.60      |
|                        |                                | P1                     | 5L2 OOS w/o RAS  | 492.10   | 2248.10       | 1123.70       | 93.50      |
|                        |                                |                        |                  | 69.80 %  | 97.70 %       | 57.60 %       | 26.30 %    |
|                        |                                | P1                     | 5L13 OOS w/o RAS | 487.60   | 1519.70       | 1687.50       | 83.50      |
|                        |                                |                        |                  | 68.90 %  | 66.10 %       | 86.50 %       | 23.40 %    |
| Summer Rating in MVA/A |                                |                        |                  | -  | 2300 A        | 1950 A        | 300 MVA    |
| 30HS                   | Max                            | P0                     | System Normal    | 497.40   | 1553.10       | 1248.50       | 100.40     |
|                        |                                |                        |                  | 70.80 %  | 67.50 %       | 64.00 %       | 33.50 %    |
|                        |                                | P1                     | 2L319 OOS        | 506.20   | 1620.80       | 1265.70       | 149.20     |
|                        |                                |                        |                  | 72.40 %  | 70.50 %       | 64.90 %       | 49.70 %    |
|                        |                                | P1                     | 5L2 OOS w/o RAS  | 488.40   | 2312.50       | 1265.10       | 87.40      |
|                        |                                |                        |                  | 69.00 %  | 100.50 %      | 64.90 %       | 29.10 %    |
|                        |                                | P1                     | 5L13 OOS w/o RAS | 487.70   | 1565.50       | 1890.70       | 86.00      |
|                        |                                |                        |                  | 68.90 %  | 68.10 %       | 97.00 %       | 28.70 %    |
| 30LS                   | Max                            | P0                     | System Normal    | 501.30   | 1602.40       | 1326.30       | 121.90     |
|                        |                                |                        |                  | 71.50 %  | 69.70 %       | 68.00 %       | 40.60 %    |
|                        |                                | P1                     | 2L319 OOS        | 509.20   | 1660.60       | 1339.20       | 173.80     |
|                        |                                |                        |                  | 73.00 %  | 72.20 %       | 68.70 %       | 57.90 %    |
|                        |                                | P1                     | 5L2 OOS w/o RAS  | 496.10   | 2369.30       | 1341.50       | 115.60     |
|                        |                                |                        |                  | 70.60 %  | 103.00 %      | 68.80 %       | 38.50 %    |
|                        |                                | P1                     | 5L13 OOS w/o RAS | 500.62   | 1467.79       | 2005.03       | 105.07     |
|                        |                                |                        |                  | 68.70%   | 63.80%        | 102.80%       | 35.00%     |

**Table B-2: Steady-State Voltage Study Results**

| Case | IC's Generator Output | Contingency |                            | Bus Voltage (PU) |            |                  |
|------|-----------------------|-------------|----------------------------|------------------|------------|------------------|
|      |                       | Category    | Description                | KDS 230 kV       | KDS 500 kV | P58 Tap on 2L320 |
| 29HW | Max                   | P0          | System Normal              | 1.01             | 1.06       | 1.04             |
|      | 0 MW                  | P0          | System Normal (no outputs) | 1.05             | 1.07       | 1.05             |
|      | Max                   | P1          | 2L319 OOS                  | 1.02             | 1.06       | 1.04             |
|      |                       | P1          | 1L368 OOS                  | 1.01             | 1.06       | 1.04             |
| 30HS | Max                   | P0          | System Normal              | 1.01             | 1.06       | 1.04             |
|      | 0 MW                  | P0          | System Normal (no outputs) | 1.05             | 1.07       | 1.05             |
|      | Max                   | P1          | 2L319 OOS                  | 1.01             | 1.06       | 1.04             |
|      |                       | P1          | 1L368 OOS                  | 1.01             | 1.06       | 1.04             |
| 30LS | Max                   | P0          | System Normal              | 1.02             | 1.08       | 1.05             |
|      | 0 MW                  | P0          | System Normal (no outputs) | 1.08             | 1.08       | 1.09             |
|      | Max                   | P1          | 2L319 OOS                  | 1.03             | 1.08       | 1.05             |
|      |                       | P1          | 1L368 OOS                  | 1.02             | 1.08       | 1.05             |

## Appendix C One-Line Sketch for Work at KDS Substation

Figure C-1 shows the Stations Planning One-Line Sketch for the substation work required at KDS.

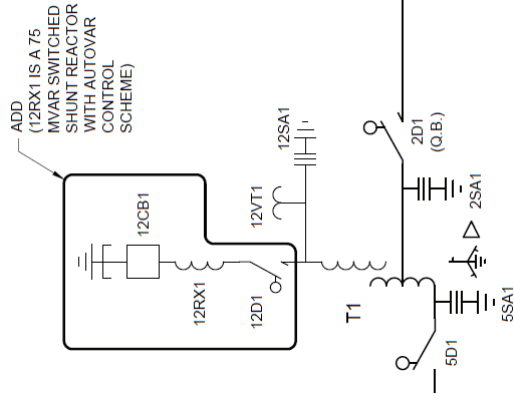

Figure C-1: Stations Planning One-Line Sketch for the substation work required at KDS.