

6911 Southpoint Drive (B03)  
Burnaby, BC  
V3N 4X8

November 24, 2025

[REDACTED]  
[REDACTED]  
[REDACTED]  
[REDACTED]

via email [REDACTED]

**RE: CEAP IR #88 [REDACTED]**  
**Interconnection Feasibility Study**

Dear [REDACTED]

Enclosed is the Interconnection Feasibility Study for the proposed Interconnection Request (IR), [REDACTED], submitted under Attachment M-2: Transmission Service and Interconnection Service Procedures for Competitive Electricity Acquisition Process (CEAP) of the Open Access Transmission Tariff (OATT). This letter provides a non-binding good faith estimate of the cost and time to construct the facilities required to interconnect your project to BC Hydro's Transmission System, being the Network Upgrades, based on the findings of the Interconnection Feasibility Study.

### **Open Access Transmission Tariff**

The OATT defines Network Upgrades as additions, modifications, and upgrades to BC Hydro's Transmission System required at or beyond the Point of Interconnection to accommodate the interconnection of the Generating Facility to the BC Hydro's Transmission System. Pursuant to the OATT, BC Hydro will design, procure, construct, install, and own the Network Upgrades. While BC Hydro will pay the costs for the Network Upgrades, the Interconnection Customer provides security for such costs.

### **Interconnection Study Costs**

The Interconnection Customer is responsible for paying the full cost of all Interconnection Studies in cash. Interconnection Study costs vary depending on the scope, complexity, and other factors such as whether any scope is shared with another Interconnection Customer (not applicable to this Interconnection Feasibility Study). The deposit amounts specified in the OATT are not proxy Interconnection Study costs. If actual Interconnection Study costs exceed the deposit amount, the Interconnection Customer must pay the remaining balance in cash. Please refer to the answer for question no. 53 in the posted [Questions & Answers for 2025 Call for Power](#) for typical study cost ranges.

### **Cost Estimate**

Based on the Interconnection Feasibility Study, the non-binding good faith estimated cost (typical accuracy range of +150%/-50%) for Network Upgrades required to interconnect your project is \$136.1 M.

### **Major Scope of Work Identified:**

- Thermally upgrade the overhead circuit 2L93 between the POI and Kelly Lake substation (KLY)
- Acquire property and construct a new 230 kV, 3-circuit breaker ring bus switching substation

- Construct a new control building and other required substation facilities and infrastructures
- Cut the existing 2L93 and loop into the substation
- Terminate 230 kV line of [REDACTED] at the substation
- Supply and install required Protection, Control and Telecommunications equipment

**Exclusions:**

- GST
- Permits
- Right-of-Way & property costs

**Key Assumptions:**

- Construction by contractor
- 24 months of construction is considered
- No construction during winter season
- Execution of early Engineering and Procurement Agreement
- Ability to acquire adequate property for a new switching station close to the existing transmission line 2L93
- No expansion of existing stations or control buildings to accommodate new equipment
- Impact Benefit Agreements with First Nations are not considered
- Only structure replacements, no reconductoring were assumed for line upgrade (33km)

**Key Risks:**

- Cost and ability of obtaining new property for the new switching station may be higher than estimated which may increase the Network Upgrade cost estimate and schedule.
- Expansion of the existing control building may be required leading to increased costs and/or a longer project schedule
- Transmission scope may be different than assumed, including number of structure replacements. Major equipment delivery presents potential project cost and schedule risks, based on variance in equipment lead times
- No defined supply chain strategy; construction costs may increase depending on delivery method
- Project schedule may be longer than expected, leading to increased overhead costs
- Ground improvements may be required leading to increased construction costs
- Contaminated soil may be encountered leading to increased construction costs
- Cost of materials and major equipment may be affected by market conditions and escalation

**Study Limitations and Exclusions*****Protection, Control, and Telecommunications***

The Interconnection Feasibility Study does not include a detailed review of the protection, control, and telecommunications system requirements specific to your Interconnection Request. Based on a high-level review, we have identified proxy costs for protection, control, and telecom Network Upgrades drawn from comparable interconnection projects with similar scope and complexity; these proxy costs have been included solely for indicative budgeting purposes. The relative interconnection cost determined by the Interconnection Feasibility Study includes a telecommunications component based on an assumed solution

to deliver teleprotection and telecontrol circuit requirements necessary for the Interconnection Request. Protection, control, and telecommunications system requirements will be reviewed in detail in the System Impact Study if you are a successful participant of the CEAP and meet applicable requirements.

For Interconnection Feasibility Study purposes, it is assumed that any applicant-proposed works that could obstruct or impair the performance of existing BC Hydro microwave systems or new links from the proposed Interconnection Customer Interconnection Facilities (ICIF) to the BC Hydro microwave system would be identified and either relocated or repositioned as determined in a System Impact Study if you are a successful participant of the CEAP and meet applicable requirements. Such works may include, but are not limited to, towers, turbines, dams, support structures, panels, surface materials deposited or redistributed, water surface changes, or vegetation.

### ***Generation Shedding/Curtailment Scheme and Electromagnetic Transient (EMT) Studies***

The generation shedding/curtailment scheme reviews (e.g., Remedial Action Scheme (RAS), and a direct transfer trip for anti-islanding scheme) and EMT studies are completed in a System Impact Study. The outcomes of these studies may result in additional requirements, which could include Network Upgrades or ICIF. Any costs associated with completion of these studies, and resulting requirements, are not included in the Interconnection Feasibility Study cost estimate.

### ***Revenue Metering***

Please note that revenue metering requirements have not been determined with the Interconnection Feasibility Study. As such, any costs associated with revenue metering and other interconnection components are not included in the cost estimate provided above. Once these requirements are defined, costs that are attributable to the Interconnection Customer are to be paid in cash. For more details on revenue metering requirements and responsibilities, please refer to:

<https://www.bchydro.com/content/dam/BCHydro/customer-portal/documents/distribution/standards/ds-rmr-complex-revenue-metering.pdf>.

### **Schedule**

Based on the Interconnection Feasibility Study, the non-binding good faith estimated in-service date for your Interconnection Request's Network Upgrades is Quarter 3 2033 (calendar year). To achieve this timeline, we may need to expedite certain activities, including engineering design and procurement of long-lead equipment.

Timely actions required from you to minimize risks to the schedule:

- Submission of additional technical data required for the System Impact Study and Facilities Study
- Submission of any required information or document such as demonstration of Site Control
- Execution of Combined Study Agreement and Standard Generator Interconnection Agreement
- Financial commitments and securities

Please note that changes to your Interconnection Request or delays in data submission or financial commitments may also impact the target in-service date.

If you have any questions, please contact the BC Hydro CEAP team at [ceap2025@bchydro.com](mailto:ceap2025@bchydro.com).

Sincerely,

[Redacted signature]

[Redacted name]

Manager, Customer Interconnections

BC Hydro

Encl.: CEAP\_2025\_IR88\_ [Redacted] \_Feasibility\_Study.pdf



## Interconnection Feasibility Study

**BC Hydro EGBC Permit to Practice No: 1002449**

**2025 CEAP IR #88**

Prepared for:



Prepared by:

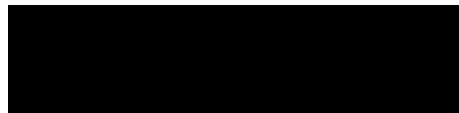

Engineer, Transmission Planning

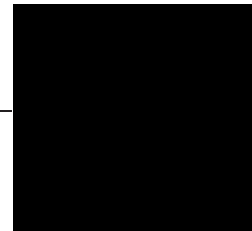

Reviewed by:

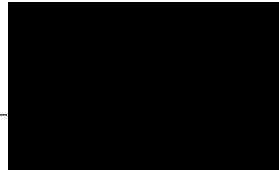

Principal Engineer, Transmission Planning

Accepted by:

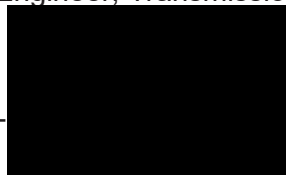

Manager, Growth Capital Planning

## Report Metadata

Header: 2025 CEAP IR #88  
Subheader: Interconnection Feasibility Study  
Title: [REDACTED]  
Subtitle: 2025 CEAP IR #88  
Report Number: 300-APR-00052  
Revision: 0  
Confidentiality: Public  
Date: 2025 Nov 21  
Volume: 1 of 1

Prepared for: [REDACTED]  
Prepared by: [REDACTED]  
Title: Engineer, Transmission Planning  
Checked by: [REDACTED]  
Title: Consultant, Transmission Planning  
Reviewed by: [REDACTED]  
Title: Principal Engineer, Transmission Planning

Related Facilities: KLY, SVA, 2L93 (230kV)  
Additional Metadata: Transmission Planning 2025-108  
Filing Subcode 1350

## Revisions

Revision	Date	Description
0	2025 Nov	Initial release

## Disclaimer of Warranty, Limitation of Liability

This report was prepared solely for internal purposes. All parties other than BC Hydro are third parties.

BC Hydro does not represent, guarantee or warrant to any third party, either expressly or by implication:

any information, product or process disclosed, described or recommended in this report.

BC Hydro does not accept any liability of any kind arising in any way out of the use by a third party of any information, product or process disclosed, described or recommended in this report, nor does BC Hydro accept any liability arising out of reliance by a third party upon any information, statements or recommendations contained in this report. Should third parties use or rely on any information, product or process disclosed, described or recommended in this report, they do so entirely at their own risk.

This report was prepared by the British Columbia Hydro And Power Authority ("BCH") or, as the case may be, on behalf of BCH by persons or entities including, without limitation, persons or entities who are or were employees, agents, consultants, contractors, subcontractors, professional advisers or representatives of, or to, BCH (individually and collectively, "BCH Personnel").

This report is to be read in the context of the methodology, procedures and techniques used, BCH's or BCH's Personnel's assumptions, and the circumstances and constraints under which BCH's mandate to prepare this report was performed. This report is written solely for the purpose expressly stated in this report, and for the sole and exclusive benefit of the person or entity who directly engaged BCH to prepare this report. Accordingly, this report is suitable only for such purpose, and is subject to any changes arising after the date of this report. This report is meant to be read as a whole, and accordingly no section or part of it should be read or relied upon out of context.

Unless otherwise expressly agreed by BCH:

- (a) any assumption, data or information (whether embodied in tangible or electronic form) supplied by, or gathered from, any source (including, without limitation, any consultant, contractor or subcontractor, testing laboratory and equipment suppliers, etc.) upon which BCH's opinion or conclusion as set out in this report is based (individually and collectively, "Information") has not been verified by BCH or BCH's Personnel; BCH makes no representation as to its accuracy or completeness and disclaims all liability with respect to the Information;
- (b) except as expressly set out in this report, all terms, conditions, warranties, representations and statements (whether express, implied, written, oral, collateral, statutory or otherwise) are excluded to the maximum extent permitted by law and, to the extent they cannot be excluded, BCH disclaims all liability in relation to them to the maximum extent permitted by law;
- (c) BCH does not represent or warrant the accuracy, completeness, merchantability, fitness for purpose or usefulness of this report, or any information contained in this report, for use or consideration by any person or entity. In addition, BCH does not accept any liability arising out of reliance by a person or entity on this report, or any information contained in this report, or for any errors or omissions in this report. Any use, reliance or publication by any person or entity of this report or any part of it is at their own risk; and
- (d) In no event will BCH or BCH's Personnel be liable to any recipient of this report for any damage, loss, cost, expense, injury or other liability that arises out of or in connection with this report including, without limitation, any indirect, special, incidental, punitive or consequential loss, liability or damage of any kind.

## Copyright Notice

Copyright and all other intellectual property rights in, and to, this report are the property of, and are expressly reserved to, BCH. Without the prior written approval of BCH, no part of this report may be reproduced, used or distributed in any manner or form whatsoever.

## Contributors

The following accept responsibility for the content in the specified sections. Professionals apply their signature and/or seal as appropriate.

**Section:** The entire report except those listed below  
**Discipline:** Transmission Planning

Contributed by:

  
Principal Engineer, Transmission Planning

**Section:** 5.2, 5.3  
**Discipline:** Substations Growth and Sustainment

Contributed by:

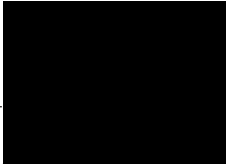
  
Specialist Engineer, Substations Growth and Sustainment

**Section:** 5.4  
**Discipline:** Transmission Line Engineering

Contributed by:

  
Senior Engineer, Transmission Line Engineering

## Executive Summary

██████████ the Interconnection Customer (IC), requests to interconnect its ██████████ (2025 CEAP IR #88) to the BC Hydro (BCH) system. ██████████ has fifty-one (51) ██████████ Type-3 wind turbine generators, adding a total installed capacity of 300.9 MW with a maximum power injection of 292 MW into the BCH system. The IC requests a Point of Interconnection (POI) on 2L93 (Kelly Lake substation (KLY) – Savona substation (SVA)), approximately 33 km from KLY. The IC’s project will connect to the POI via a 25 km long 230 kV customer-owned transmission line. The IC’s plant will have a total rated capacity of 300.9 MW and its proposed commercial operation date (COD) is October 31, 2032.

To interconnect the ██████████ ██████████ ██████████ and its facilities to the BCH Transmission System at the proposed POI, this Feasibility Study has identified the following conclusions and requirements:

1. A new 230 kV switching station on 2L93 is required to interconnect the customer’s generating project to the BCH system.
2. The interconnection of the ██████████ results in one system performance violation under system normal conditions – a thermal overload on circuit 2L93\_A between the POI in the new switching station and KLY under summer light load conditions. The system reinforcement required is provided below.
  - Thermal upgrade 2L93\_A between the POI and KLY with a minimum summer rating of 805 Amperes.
3. The connection of ██████████ results in multiple transmission circuits thermal violations under various single contingency conditions including loss of 2L92 KLY-SVA, breaker faults at KLY or SVA, no-fault open line terminals on 2L92 at KLY or SVA, loss of 2L93\_A KLY and POI section, loss of 2L93 POI and SVA section, and 138 kV line contingencies in the local regional system, etc. To mitigate the post contingency overloading concerns, gen-shedding at the project site is required. Further investigation into gen-shedding and Remedial Action Scheme

(RAS) will be conducted in a later System Impact Study (SIS) stage if the project proceeds.

4. The [REDACTED] is required to have the dynamic reactive power capability at a minimum of +/- 33% of its MPO at the high voltage side of the IC's switchyard over the full MW operating range, per BCH's TIR Section 6.4.2.
5. The BCH TIR requires the IC's project to provide sufficient reactive power capability over full MW operating range including at zero MW output level.
6. Fast Frequency Response, also known as Virtual Inertia Control (VIC) in the proposed wind turbines, is required at the [REDACTED]. The proposed wind turbine generators, when equipped with the VIC option, are expected to temporarily boost the MW output to limit the system frequency drop during a major frequency event. The VIC settings should be determined in coordination with BCH in the later stage of the interconnection process.

The above conclusions are made based on the IC's input data and study assumptions listed in Section 4, which represent the best available information on October 14, 2025.

A non-binding good faith cost for required network upgrades and estimated schedule for construction are included in a separate letter to the IC.

Please note that, this Feasibility Study report does not include the descriptions of Protection, Control, and Telecommunications requirements and the associated upgrade scopes; however, as discussed in Section 2 "Purpose and Scopes of Study", the associated cost implications are captured and delivered in the cover letter to the IC.

# Contents

<b>Executive Summary</b>	<b>vi</b>
<b>1 Introduction</b>	<b>1</b>
<b>2 Purpose and Scopes of Study</b>	<b>3</b>
<b>3 Standard and Criteria</b>	<b>4</b>
<b>4 Assumptions and Conditions</b>	<b>5</b>
<b>5 System Studies and Results</b>	<b>6</b>
5.1 Power Flow Study Results	6
5.1.1 Branch Loading Analysis	6
5.1.2 Steady-State Voltage Analysis	7
5.1.3 Reactive Power Capability Evaluation	7
5.1.4 Anti-Islanding Requirements	7
5.2 Fault Analysis	7
5.3 Stations Requirements	7
5.4 Transmission Line Requirements	8
<b>6 Cost Estimate and Schedule</b>	<b>9</b>
<b>7 Conclusions</b>	<b>10</b>

## Appendices

Appendix A	Plant Single Line Diagram Used for Power Flow Study
Appendix B	Power Flow Study Results
Appendix C	One-Line Sketch for New Switching Station

## Acronyms

The following are acronyms used in this report.

BCH	BC Hydro
CEAP	Competitive Electricity Acquisition Process
COD	Commercial Operation Date
ERIS	Energy Resource Interconnection Service
FeS	Feasibility Study
FVO	Fraser Valley Office
IBR	Inverter-Based Resources
IC	Interconnection Customer
IR	Interconnection Request
MPO	Maximum Power Output
NERC	North American Electric Reliability Corporation
NRIS	Network Resource Interconnection Service
OATT	Open Access Transmission Tariff
■	■ ■ ■
POI	Point of Interconnection
RAS	Remedial Action Scheme
SIO	South Interior Office
SIS	System Impact Study
SIW	South Interior West
TIR	BC Hydro “60 kV to 500 kV Technical Interconnection Requirements for Power Generators”
WECC	Western Electricity Coordinating Council
WTG	Wind Turbine Generator

# 1 Introduction

Table 1-1 below summarizes the project reviewed in this Feasibility Study.

Table 1-1 Summary of Project Information

Project Name	[REDACTED]	
Name of Interconnection Customer (IC)	[REDACTED]	
Point of Interconnection (POI)	2L93, 33 km from KLY substation	
IC's Proposed COD	October 31, 2032	
Type of Interconnection Service	NRIS <input checked="" type="checkbox"/>	ERIS <input type="checkbox"/>
Maximum Power Injection (MW)	292 (Summer)	292 (Winter)
Number of Generator Units	51 x 5.9 MW WTGs	
Plant Fuel	Wind	

[REDACTED] the Interconnection Customer (IC), requests to interconnect its [REDACTED] (2025 CEAP IR # 88) to the BC Hydro (BCH) system adding a total installed capacity of 292 MW with a maximum power injection of 292 MW into the BCH system. The [REDACTED] has fifty-one (51) [REDACTED] wind turbine generators rated 6.35 MVA/5.9 MW, 0.75 kV, each with a 6.35 MVA, 0.75/34.5 kV wye/delta step-up transformer. Eleven 34.5 kV collector feeders connect the generators to a 34.5/230 kV collector station/substation with 2 – 225 MVA, 34.5/230 kV YG-YG transformers. The IC's 25 km, 230 kV transmission line interconnects the substation to the POI. The Point of Interconnection (POI) is a new 230 kV switching station on BCH's 230 kV line 2L93, approximately 33 km from Kelly Lake (KLY) Substation. Refer to appendix A for a plant single-line diagram.

Figure 1 shows a portion of the South Interior West (SIW) regional transmission system in which the IPP is located. The Kamloops-Highland-Merritt area in the SIW region of BC is supplied primarily by three 230 kV transmission lines and one 138 kV transmission line: 2L93 KLY-SVA, 2L92 KLY-SVA, 2L265 NIC-Valleyview (VWV) and 1L243 NIC-Highland (HLD). 2L93 primarily supplies the western half of the Kamloops area and part of the Highland area along with 2L92.

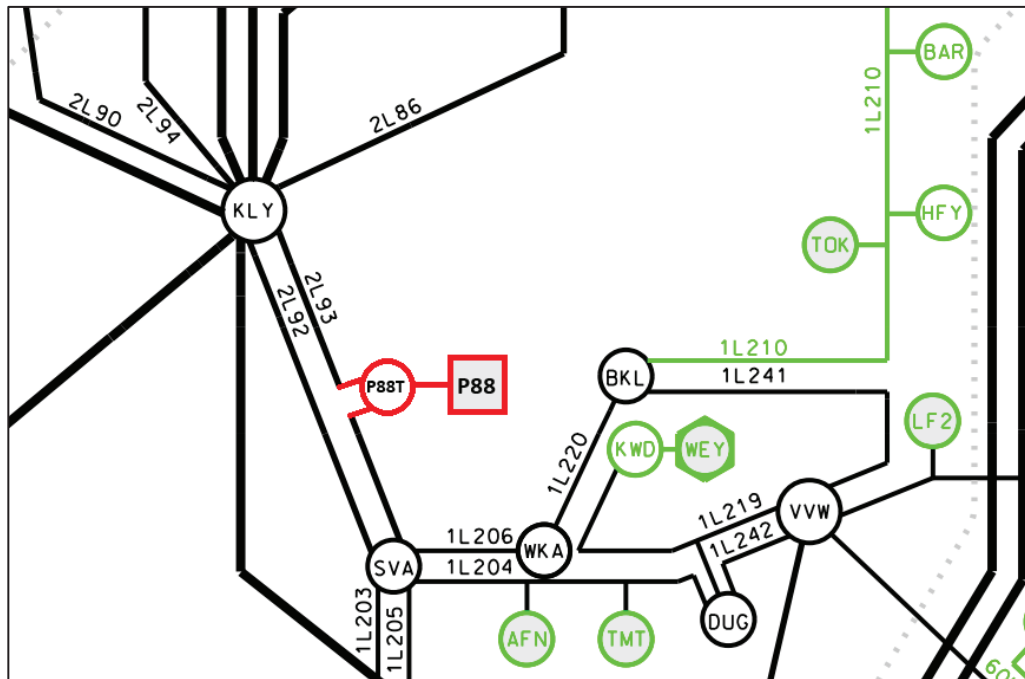

Figure 1-1: Existing SIW Transmission System with [REDACTED] Added.

## 2 Purpose and Scopes of Study

This Feasibility Study is a preliminary evaluation of the system impact of interconnecting the proposed project to the BCH system based on power flow and short circuit analysis in accordance with BCH's Open Access Transmission Tariff (OATT) and produces the estimated cost of required Network Upgrades and the implementation schedule.

Per OATT, the feasibility study is performed individually for each of the participating projects in the CEAP and focuses specifically on the BCH regional transmission system where the proposed generating project is proposed to be constructed.

This is a "limited scope" study which is restricted to power flow studies of P0, P1 and P2 planning events as defined in TPL-001-4 and short circuit analysis. The study does not address other technical aspects such as transient stability and switching transients and impact of multiple contingencies. These subjects will be addressed in subsequent System Impact Study (SIS) if the project proceeds further. In addition, any potential impacts to the adjacent external systems to BCH would be addressed in subsequent detailed and coordinated studies with the relevant adjacent entities if the proposed generator project proceeds further.

Please note that, due to the compressed study timeline for 2025 CEAP Feasibility Studies, this report does not include the descriptions of the Protection, Control, and Telecommunication requirements and the associated upgrade scopes. Instead, the network upgrades associated with Protections, Controls and Telecommunications are incorporated with cost estimates in a separate cover letter to the IC.

### 3 Standard and Criteria

The Feasibility Study is performed in compliance with the North American Electric Reliability Corporation (NERC) and Western Electricity Coordinating Council (WECC) reliability standards, and the BCH interconnection requirements in the TIR, and upon the ratings of the existing BCH transmission facilities described in Operating Orders, specifically:

- NERC standards: TPL-001-4 and FAC-002-3 relevant to the scope of this Feasibility Study.
- WECC criteria TPL-001-WECC-CRT-4 Transmission System Planning Performance, July 1, 2023.
- BCH's 60 kV to 500 kV Technical Interconnection Requirements for Power Generators, Rev 2.1.1, Effective: Sept 22, 2025.
- BCH Operating Order 5T-10, Ratings for All Transmission Circuits 60 kV or Higher, Sept 17, 2025.
- BCH Operating Order 5T-14, Ratings for All Transmission and Distribution Transformer, Sept 22, 2025.
- BCH System Operating Order 7T-22 System Voltage Control, Sept 19, 2023.

## 4 Assumptions and Conditions

This Feasibility Study is performed based on the IC's submitted data and information available to BCH on Oct 14, 2025 for the study purpose. Assumptions are made wherever the IC's input is unavailable. Appendix A shows the schematic diagram of the IC's project used in the study model.

The power flow study cases used in this Feasibility Study are established based upon the BCH's base resource plan and load forecasts available at the time of performing the study, which includes existing and future generators, transmission facilities, and loads in addition to the subject interconnection project in this study. Applicable seasonal conditions and the appropriate study years for the study planning horizon are also incorporated. Additional assumptions are listed as follows.

- The generation in the study area are dispatched to the patterns that stress the transmission system in the study area. In these patterns, the associated generators are typically set to their Maximum Power Outputs (MPO) unless otherwise specified.
- The study area was assumed to include the 230 kV system between KLY and SVA and adjacent 138 kV transmission systems.

## 5 System Studies and Results

Based upon the IC's submitted information and the area system conditions, a new switching station (referred to as "P88T") on 2L93 is proposed as the POI to interconnect the IC's generating project with the BCH system. There are multiple terminals and multiple sources on the existing line 2L93. The addition of the new switching station is required to maintain reliability performance to accommodate the new interconnection and serve the existing customers.

With the new switching station P88T, the existing line 2L93 will be segregated into two new lines, temporarily referred to as: 2L93\_A (KLY-P88T), 2L93\_B (P88T-SVA). The proposed IC-built 230 kV line (P88T-P88) will be designated as 2L93\_C. The temporary circuit designations will be replaced by permanent designations at a later stage of interconnection study.

### 5.1 Power Flow Study Results

Power flow studies were performed to evaluate whether the IC's generating project would cause any unacceptable system performance (e.g. equipment overloads, steady-state voltage violation and voltage instability) and to determine the reinforcement requirement based on steady state performance analysis.

The study has been conducted with the focus on the 2033 light summer (33LS) system condition, taking into considerations of factors such as load conditions, seasonal variation in ambient temperatures, and generation patterns that stress the transmission system. The 2032 heavy winter (32HW), 2033 light summer (33LS), and 2033 heavy summer (33HS) cases are also checked at a high level to capture any performance violations under high load conditions.

#### 5.1.1 Branch Loading Analysis

The study finds one thermal violation under system normal conditions – an overload on circuit 2L93\_A between the POI at the new switching station and KLY under summer light load conditions and the proposed system upgrade is as follows:

- Upgrade circuit 2L93\_A between the POI and KLY for a minimum summer rating of 805 A.

Table B-1 in appendix B shows the details of branch loading analysis under system normal and single contingencies (P1, P2) for various load conditions.

### **5.1.2 Steady-State Voltage Analysis**

For all the studied load conditions (33LS, 33HS, and 32HW), the voltage performance under system normal condition (P0) is acceptable.

### **5.1.3 Reactive Power Capability Evaluation**

The BCH TIR requires IBR generators have the dynamic reactive power capability at a minimum of +/- 33% of its Maximum Power Output (MPO) at the high voltage side of the IC's switchyard over the full MW operating range.

Based on the power flow model data submitted by the IC, the proposed [REDACTED] [REDACTED] would be capable of meeting the BCH's reactive capability requirement at the plant's maximum MW output, which is subjected to further verification in the next stage of the interconnection process.

Furthermore, the BCH TIR requires the IC's project to provide sufficient reactive power capability over full MW operating range including at zero MW output level.

### **5.1.4 Anti-Islanding Requirements**

[REDACTED] is not allowed to operate in islanded operation. Anti-islanding protection installed within IC's facility shall be configured in the manner that does not compromise the required ride-through performance.

## **5.2 Fault Analysis**

The short circuit analysis in the Feasibility Study is based upon the latest BCH system model, which includes the generating facility information and associated impedance data provided by the IC. A more detailed study will be performed at the SIS stage if needed.

## **5.3 Stations Requirements**

A new outdoor 230 kV, 3-circuit breaker ring bus switching substation, P88T, will be built at POI, close to the existing 230 kV transmission line 2L93. The existing

transmission line 2L93 will be cut and looped into P88T. The IC's 230 kV circuit will be terminated at the new substation, P88T.

- Acquire adequate property for a new substation close to the existing transmission line 2L93.
- Construct a new outdoor 230 kV, 3-circuit breaker ring bus switching substation. Refer to the one-line diagram in Appendix C for details.
- Construct a new control building and other required substation facilities and infrastructures.
- Loop the existing 2L93 into the substation.
- Terminate 230 kV line of [REDACTED] at the substation.
- The location of metering kits will be determined in next stage.

## 5.4 Transmission Line Requirements

Thermally upgrade the overhead circuit 2L93 (POI to KLY) to required 805 A (40°C ambient summer temperature) by uprating the normal conductor operating temperature from 49° C to 72° C. Structure replacements may be required.

## 6 Cost Estimate and Schedule

The non-binding good faith estimated cost and time to construct the Network Upgrades required to interconnect the proposed project will be provided in a separate letter to the IC.

## 7 Conclusions

To interconnect the [REDACTED] [REDACTED] [REDACTED] and its facilities to the BCH Transmission System at the POI, this Feasibility Study has identified the following conclusions and requirements:

1. A new 230 kV switching station on 2L93 is required to interconnect the customer's generating project to the BCH system.
2. The connection of the [REDACTED] results in one thermal violation under system normal conditions – an overload on circuit 2L93\_A between the POI at the new switching station and KLY under summer light load conditions and the proposed system upgrade is as follows:
  - Thermal upgrade 2L93\_A between POI and KLY with a minimum summer rating of 805 Amperes.
3. The connection of [REDACTED] results in multiple transmission circuits thermal violations under various single contingency conditions including loss of 2L92 KLY-SVA, breaker faults at KLY or SVA, no-fault open line terminals on 2L92 at KLY or SVA, loss of 2L93\_A KLY and POI section, loss of 2L93 POI and SVA section, 138 kV line contingencies in the local regional system, etc. To mitigate the post contingency overloading concerns, gen-shedding at the project site is required. Further investigation into gen-shedding and remedial action scheme (RAS) will be conducted in a later System Impact Study (SIS) stage if the project proceeds.
4. The [REDACTED] is required to have the dynamic reactive power capability at a minimum of +/- 33% of its MPO at the high voltage side of the IC's switchyard over the full MW operating range, per BCH's TIR Section 6.4.2.
5. The BCH TIR requires the IC's project to provide sufficient reactive power capability over full MW operating range including at zero MW output level.

6. Fast Frequency Response, also known as Virtual Inertia Control (VIC) in the proposed wind turbines, is required at the [REDACTED]. The proposed wind turbine generators, when equipped with the VIC option, are expected to temporarily boost the MW output to limit the system frequency drop during a major frequency event. The VIC settings should be determined in coordination with BCH in the later stage of the interconnection process.

## Appendix A

### Plant Single Line Diagram Used for Power Flow Study

Figure A-1 shows [REDACTED] single line diagram used for power flow study.

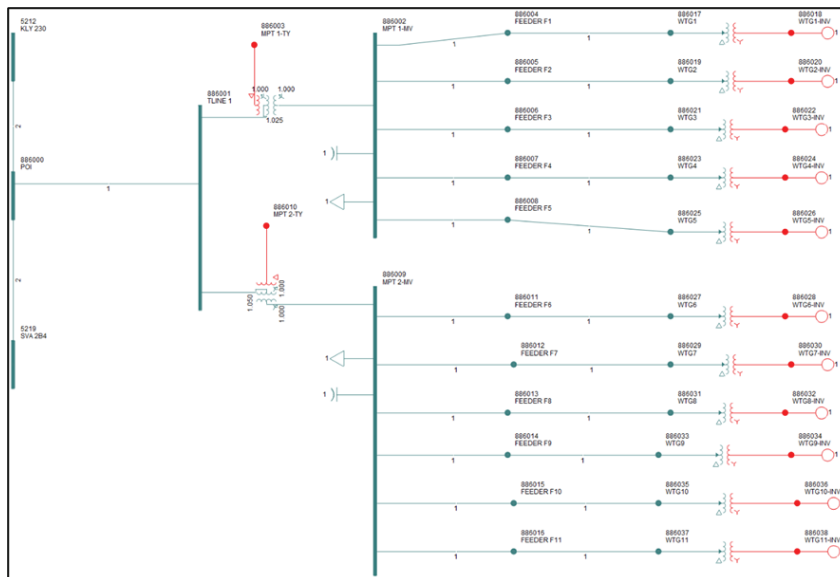

Figure A-1: [REDACTED] Single Line Diagram for Power Flow Study.

As seen in the diagram, [REDACTED] has two main power transformers dividing the plant into two parts. One part has five (5) equivalent feeders and the other six (6) equivalent feeders.

## Appendix B Power Flow Study Results

Table B-1: Summary of branch loading study results.

Case	IPP's Generator Output	Contingency Identified		Branch Loading		
		Category	Description	2L92 KLY-SVA	2L93 A KLY-P88T	2L93 B P88T-SVA
32HW	300.9 MW	P0	System Normal	23.7%	64.2%	6.5%
32HW	300.9 MW	P1.2	2L92 + SVA_T3 OOS	N/A	76.1%	11.8%
32HW	300.9 MW	P1.2	2L93_A OOS	66.9%	N/A	66.4%
32HW	300.9 MW	P1.2	2L93_B + SVA T1 OOS	19.7%	66.2%	N/A
33HS	300.9 MW	P0	System Normal	48.9%	125.3%	16.7%
33HS	300.9 MW	P1.2	2L92 + SVA_T3 OOS	N/A	150%	33.5%
33HS	300.9 MW	P1.2	2L93_A OOS	127.4%	N/A	122.3%
33HS	300.9 MW	P1.2	2L93_B + SVA T1 OOS	45.3%	121.2%	N/A
33LS	300.9 MW	P0	System Normal	50.7%	126.3%	21.8%
33LS	300.9 MW	P1.2	2L92 + SVA_T3 OOS	N/A	151%	37.7%
33LS	300.9 MW	P1.2	2L93_A OOS	129.6%	N/A	123%
33LS	300.9 MW	P1.2	2L93_B + SVA T1 OOS	48.6%	121.3%	N/A

Table B-2: Summary of steady state voltage study results.

Case	IPP's Generator Output	Contingency		Bus Voltage (PU)		
		Category	Description	KLY 230	SVA 230	SVA 138
32HW	300.9 MW	P0	System Normal	1.05	1.051	1.021
32HW	300.9 MW	P1.2	2L92 + SVA_T3 OOS	1.05	1.054	1.019
32HW	300.9 MW	P1.2	2L93_A OOS	1.042	1.039	1.02
32HW	300.9 MW	P1.2	2L93_B + SVA T1 OOS	1.05	1.044	1.014
32HW	300.9 MW	P2.1	2L93_A open at KLY	1.042	1.04	1.02
32HW	300.9 MW	P2.1	2L93_B open at SVA	1.05	1.04	1.016
33HS	300.9 MW	P0	System Normal	1.052	1.046	1.021
33HS	300.9 MW	P1.2	2L92 + SVA_T3 OOS	1.052	1.049	1.019
33HS	300.9 MW	P1.2	2L93_A OOS	1.043	1.033	1.021
33HS	300.9 MW	P1.2	2L93_B + SVA T1 OOS	1.052	1.038	1.014
33HS	300.9 MW	P2.1	2L93_A open at KLY	1.043	1.034	1.021
33HS	300.9 MW	P2.1	2L93_B open at SVA	1.052	1.032	1.015
33LS	300.9 MW	P0	System Normal	1.051	1.038	1.03
33LS	300.9 MW	P1.2	2L92 + SVA_T3 OOS	1.052	1.04	1.023
33LS	300.9 MW	P1.2	2L93_A OOS	1.042	1.024	1.029
33LS	300.9 MW	P1.2	2L93_B + SVA T1 OOS	1.051	1.026	1.016
33LS	300.9 MW	P2.1	2L93_A open at KLY	1.042	1.025	1.029
33LS	300.9 MW	P2.1	2L93_B open at SVA	1.05	1.017	1.02

## Appendix C

### One-Line Sketch for New Switching Station

Figure C-1 shows the Stations Planning One-Line Sketch for the New Switching Station P88T.

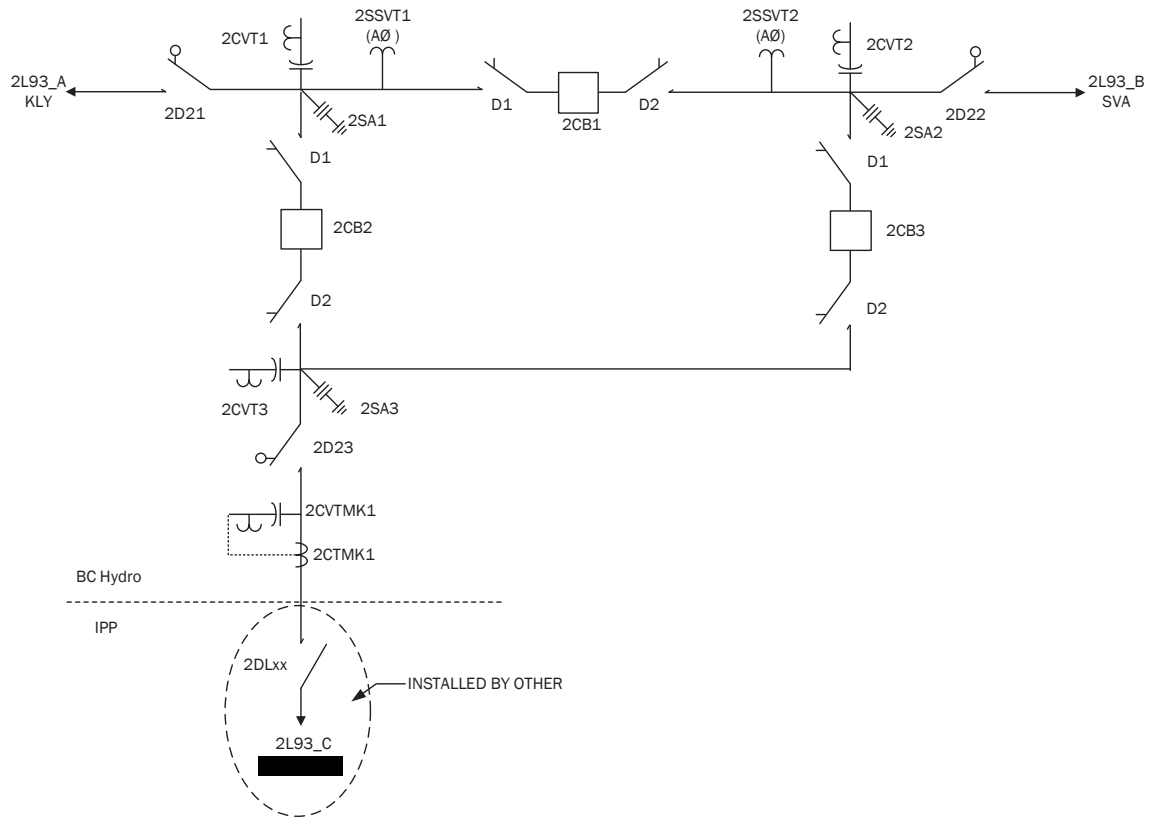

Figure C-1: Stations Planning One-Line Sketch for the New Switching Station P88T.