

6911 Southpoint Drive (B03)
Burnaby, BC
V3N 4X8

November 24, 2025

[REDACTED]

via email: [REDACTED]

RE: CEAP IR #60 – [REDACTED] – Interconnection Feasibility Study

Dear [REDACTED]

Enclosed is the Interconnection Feasibility Study for the proposed Interconnection Request (IR), [REDACTED], submitted under Attachment M-2: Transmission Service and Interconnection Service Procedures for Competitive Electricity Acquisition Process (CEAP) of the Open Access Transmission Tariff (OATT). This letter provides a non-binding good faith estimate of the cost and time to construct the facilities required to interconnect your project to BC Hydro's Transmission System, being the Network Upgrades, based on the findings of the Interconnection Feasibility Study.

Open Access Transmission Tariff

The OATT defines Network Upgrades as additions, modifications, and upgrades to BC Hydro's Transmission System required at or beyond the Point of Interconnection to accommodate the interconnection of the Generating Facility to the BC Hydro's Transmission System. Pursuant to the OATT, BC Hydro will design, procure, construct, install, and own the Network Upgrades. While BC Hydro will pay the costs for the Network Upgrades, the Interconnection Customer provides security for such costs.

Interconnection Study Costs

The Interconnection Customer is responsible for paying the full cost of all Interconnection Studies in cash. Interconnection Study costs vary depending on the scope, complexity, and other factors such as whether any scope is shared with another Interconnection Customer (not applicable to this Interconnection Feasibility Study). The deposit amounts specified in the OATT are not proxy Interconnection Study costs. If actual Interconnection Study costs exceed the deposit amount, the Interconnection Customer must pay the remaining balance in cash. Please refer to the answer for question no. 53 in the posted [Questions & Answers for 2025 Call for Power](#) for typical study cost ranges.

Cost Estimate

Based on the Interconnection Feasibility Study, the non-binding good faith estimated cost (typical accuracy range of +150%/-50%) for Network Upgrades required to interconnect your project is \$70.7 M.

Major Scope of Work Identified:

- At the planned East Groundbirch switching station (EGB), add two, new 230 kV circuit breakers 2CB1 and 2CB5 with associated disconnects to expand the 230 kV three-circuit breaker ring bus to a five-circuit breaker ring bus

- Remove 2L333 connection with bus 2B3 and temporarily re-terminate it on bus 2B1 between 2CB10 and 2CB1
- Add a new 230 kV line terminal with associated disconnect, surge arrester and capacitor voltage transformer between 2CB5 and 2CB10
- Terminate [REDACTED] 230 kV transmission line at the new line terminal
- Other associated station work
- Expand the control building, if required, to accommodate new P&C panels and other equipment
- Expand the existing station fence within the property line to accommodate the additional facilities
- Supply and install required Protection, Control and Telecommunications equipment

Exclusions:

- GST
- Permits
- Right-of-Way & property costs

Key Assumptions:

- Construction by contractor
- 12 months of construction is considered
- No construction during winter season
- Execution of early Engineering and Procurement Agreement
- EGB will be in-service
- Ability to expand EGB
- Site expansion of 71 m × 143 m is assumed to accommodate the new line position at EGB
- No expansion of existing control buildings to accommodate new equipment
- Impact Benefit Agreements with First Nations are not considered

Key Risks:

- Cost and ability to expand EGB may be higher than estimated which may increase the Network Upgrade cost estimate and schedule
- Potential [REDACTED] issues limiting the expansion at EGB
- Expansion of the existing control building may be required leading to increased costs and/or a longer project schedule
- Major equipment delivery presents potential project cost and schedule risks, based on variance in equipment lead times
- No defined supply chain strategy; construction costs may increase depending on delivery method
- Project schedule may be longer than expected, leading to increased overhead costs
- Ground improvements may be required leading to increased construction costs
- Contaminated soil may be encountered leading to increased construction costs
- Cost of materials and major equipment may be affected by market conditions and escalation

Study Limitations and Exclusions

Protection, Control, and Telecommunications

The Interconnection Feasibility Study does not include a detailed review of the protection, control, and telecommunications system requirements specific to your Interconnection Request. Based on a high-level review, we have identified proxy costs for protection, control, and telecom Network Upgrades drawn from comparable interconnection projects with similar scope and complexity; these proxy costs have been included solely for indicative budgeting purposes. The relative interconnection cost determined by the Interconnection Feasibility Study includes a telecommunications component based on an assumed solution to deliver teleprotection and telecontrol circuit requirements necessary for the Interconnection Request. Protection, control, and telecommunications system requirements will be reviewed in detail in the System Impact Study if you are a successful participant of the CEAP and meet applicable requirements.

For Interconnection Feasibility Study purposes, it is assumed that any applicant-proposed works that could obstruct or impair the performance of existing BC Hydro microwave systems or new links from the proposed Interconnection Customer Interconnection Facilities (ICIF) to the BC Hydro microwave system would be identified and either relocated or repositioned as determined in a System Impact Study if you are a successful participant of the CEAP and meet applicable requirements. Such works may include, but are not limited to, towers, turbines, dams, support structures, panels, surface materials deposited or redistributed, water surface changes, or vegetation.

Generation Shedding/Curtailment Scheme and Electromagnetic Transient (EMT) Studies

The generation shedding/curtailment scheme reviews (e.g., Remedial Action Scheme (RAS), and a direct transfer trip for anti-islanding scheme) and EMT studies are completed in a System Impact Study. The outcomes of these studies may result in additional requirements, which could include Network Upgrades or ICIF. Any costs associated with completion of these studies, and resulting requirements, are not included in the Interconnection Feasibility Study cost estimate.

Revenue Metering

Please note that revenue metering requirements have not been determined with the Interconnection Feasibility Study. As such, any costs associated with revenue metering and other interconnection components are not included in the cost estimate provided above. Once these requirements are defined, costs that are attributable to the Interconnection Customer are to be paid in cash. For more details on revenue metering requirements and responsibilities, please refer to:

<https://www.bchydro.com/content/dam/BCHydro/customer-portal/documents/distribution/standards/ds-rmr-complex-revenue-metering.pdf>.

Schedule

Based on the Interconnection Feasibility Study, the non-binding good faith estimated in-service date for your Interconnection Request's Network Upgrades is Quarter 3 2031 (calendar year). To achieve this timeline, we may need to expedite certain activities, including engineering design and procurement of long-lead equipment.

Timely actions required from you to minimize risks to the schedule:

- Submission of additional technical data required for the System Impact Study and Facilities Study
- Submission of any required information or document such as demonstration of Site Control
- Execution of Combined Study Agreement and Standard Generator Interconnection Agreement
- Financial commitments and securities

Please note that changes to your Interconnection Request or delays in data submission or financial commitments may also impact the target in-service date.

If you have any questions, please contact the BC Hydro CEAP team at ceap2025@bchydro.com.

Sincerely,

[Redacted signature block]

[Redacted name]

Manager, Customer Interconnections

BC Hydro

Encl.: CEAP_2025_IR60_[Redacted]_Feasibility_Study.pdf



Interconnection Feasibility Study

BC Hydro EGBC Permit to Practice No: 1002449

2025 CEAP IR #60

Prepared for: [Redacted]

Prepared by: [Redacted] [Redacted]

[Redacted]
Sr. Eng. [Redacted] nning

Reviewed by: [Redacted]

[Redacted]
Technical Strategic Principle, Transmission
Planning

Accepted by: [Redacted]

[Redacted]
Division Manager, Transmission Planning

Report Metadata

Header: [REDACTED]
Subheader: Interconnection Feasibility Study
Title: [REDACTED]
Subtitle: 2025 CEAP IR #60
Report Number: 1000-APR-00056
Revision: 0
Confidentiality: Public
Date: 2025 Nov 21
Volume: 1 of 1

Prepared for: [REDACTED].
Prepared by: [REDACTED]
Title: Sr. Engineer, Transmission Planning
Checked by: N/A
Title: N/A
Reviewed by: [REDACTED]
Title: Technical Strategic Principle, Transmission Planning

Related Facilities: 2L333
Additional Metadata: Transmission Planning 2025-088
Filing Subcode 1350

Revisions

Revision	Date	Description
0	2025 Nov	Initial release

Disclaimer of Warranty, Limitation of Liability

This report was prepared solely for internal purposes. All parties other than BC Hydro are third parties.

BC Hydro does not represent, guarantee or warrant to any third party, either expressly or by implication:

any information, product or process disclosed, described or recommended in this report.

BC Hydro does not accept any liability of any kind arising in any way out of the use by a third party of any information, product or process disclosed, described or recommended in this report, nor does BC Hydro accept any liability arising out of reliance by a third party upon any information, statements or recommendations contained in this report. Should third parties use or rely on any information, product or process disclosed, described or recommended in this report, they do so entirely at their own risk.

This report was prepared by the British Columbia Hydro And Power Authority ("BCH") or, as the case may be, on behalf of BCH by persons or entities including, without limitation, persons or entities who are or were employees, agents, consultants, contractors, subcontractors, professional advisers or representatives of, or to, BCH (individually and collectively, "BCH Personnel").

This report is to be read in the context of the methodology, procedures and techniques used, BCH's or BCH's Personnel's assumptions, and the circumstances and constraints under which BCH's mandate to prepare this report was performed. This report is written solely for the purpose expressly stated in this report, and for the sole and exclusive benefit of the person or entity who directly engaged BCH to prepare this report. Accordingly, this report is suitable only for such purpose, and is subject to any changes arising after the date of this report. This report is meant to be read as a whole, and accordingly no section or part of it should be read or relied upon out of context.

Unless otherwise expressly agreed by BCH:

- (a) any assumption, data or information (whether embodied in tangible or electronic form) supplied by, or gathered from, any source (including, without limitation, any consultant, contractor or subcontractor, testing laboratory and equipment suppliers, etc.) upon which BCH's opinion or conclusion as set out in this report is based (individually and collectively, "Information") has not been verified by BCH or BCH's Personnel; BCH makes no representation as to its accuracy or completeness and disclaims all liability with respect to the Information;
- (b) except as expressly set out in this report, all terms, conditions, warranties, representations and statements (whether express, implied, written, oral, collateral, statutory or otherwise) are excluded to the maximum extent permitted by law and, to the extent they cannot be excluded, BCH disclaims all liability in relation to them to the maximum extent permitted by law;
- (c) BCH does not represent or warrant the accuracy, completeness, merchantability, fitness for purpose or usefulness of this report, or any information contained in this report, for use or consideration by any person or entity. In addition, BCH does not accept any liability arising out of reliance by a person or entity on this report, or any information contained in this report, or for any errors or omissions in this report. Any use, reliance or publication by any person or entity of this report or any part of it is at their own risk; and
- (d) In no event will BCH or BCH's Personnel be liable to any recipient of this report for any damage, loss, cost, expense, injury or other liability that arises out of or in connection with this report including, without limitation, any indirect, special, incidental, punitive or consequential loss, liability or damage of any kind.

Copyright Notice

Copyright and all other intellectual property rights in, and to, this report are the property of, and are expressly reserved to, BCH. Without the prior written approval of BCH, no part of this report may be reproduced, used or distributed in any manner or form whatsoever.

Contributors

The following accept responsibility for the content in the specified sections. Professionals apply their signature and/or seal as appropriate.

Section:

Entire report
except listed
below

Discipline:

Transmission Planning

Contributed by:

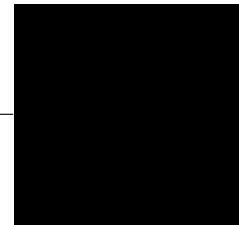

██████████
Sr. Engineer, Transmission Planning

Section:

5.2, 5.3

Discipline:

Stations Planning

Contributed by:

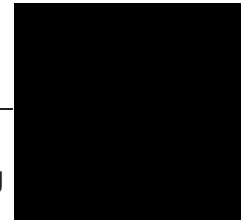
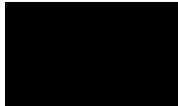

██████████
Specialist Engineer, Station Planning

Executive Summary

██████████ the interconnection customer (IC), requests to interconnect its ██████████ (2025 CEAP IR #60) to the BC Hydro (BCH) system. ██████████ has thirty (30) ██████████ type-3 wind turbine generators (WTG), adding a total installed capacity of 204 MW with a maximum power injection of 199 MW into the BC Hydro system. The IC has proposed to connect their wind project to BCH transmission system at the Point of Interconnection (POI), a tap structure located at approximately 19.5 km from the Shell Groundbirch Substation (SGB) on the BC Hydro 230 kV transmission line 2L333. ██████████ will be interconnected with the BCH transmission system at the POI via an approximately 10.6 km customer-built 230 kV line. The IC's proposed commercial operation date (COD) is Oct 1, 2029.

To interconnect the ██████████ and its facilities to the BCH Transmission System at the proposed POI, this Feasibility Study has made the requirements as follow:

1. The proposed POI, a tap structure on the 2L333 is not acceptable to interconnect the customer's generating project to BCH transmission system. Instead, it is recommended that the POI be changed to the 230 kV bus of the planned East Groundbirch (EGB) switching station, which will loop in the existing line 2L333 and is located approximately 14 km from the SGB. The EGB switching station is being built to support a TVC interconnection request and is currently in the construction phase.
2. No thermal overload or voltage constraints have been identified under system normal conditions.
3. Under single contingency conditions, regional thermal overloads were identified on 230 kV line 2L308 and Gordon M. Shrum G.S. (GMS) 500/230 kV transformers T13 or T14, while bulk system thermal overloads were identified on 500 kV lines 5L1, 5L2 and 5L3. Currently, these overloads are mitigated by the Peace Area Wind Farm Generation Shedding Remedial Action Scheme (RAS) and the G.M. Shrum Area Generation Shedding RAS, respectively. As a result, the ██████████ will be required to participate in and modify the existing Peace Area Wind Farm Gen Shedding RAS and participate in the G.M. Shrum Area Gen Shedding RAS.

The RAS function scope will be specified in the System Impact Study (SIS) stage if the need for RAS is determined.

4. ██████████ is required to install anti-islanding protection within its facility to disconnect the IC's generating plant from the grid when an inadvertent island with the local load forms. The anti-islanding protection shall be configured in the manner that does not compromise the required ride-through performance.
5. A Direct Transfer Trip (DTT) protection scheme is required to isolate the IC's wind project at the IC's entrance circuit breaker to avoid potential islanding operations with the existing or future loads.
6. The ██████████ is required to have the dynamic reactive power capability at a minimum of +/- 33% of its MPO at the high voltage side of the IC's switchyard over the full MW operating range, per BC Hydro's TIR Section 6.4.2. Based on the IC-submitted PSS/E model, the proposed ██████████ does not meet the reactive capability requirement above.
7. The "STATCOM option" for the proposed type-3 WTGs is required so that each turbine can provide reactive power capability at zero MW output. BC Hydro recognizes that Type-3 WTGs with the STATCOM option have an inherent limitation – providing only partial reactive power capability during turbine standstill.
8. Fast Frequency Response, also known as Virtual Inertia Control (VIC) in ██████████ wind turbines, is required at the ██████████. The proposed wind turbine generators, when equipped with the VIC option, are expected to temporarily boost the MW output to limit the system frequency drop during a major frequency event. The VIC settings should be determined in coordination with BC Hydro in the later stage of the interconnection process.

The above conclusions are made based on the IC's input data and study assumptions listed in Section 4, which represent the best available information on October 14, 2025.

A non-binding good faith cost for required network upgrades and estimated schedule for construction are included in a separate letter to the IC.

Please note that, this Feasibility Study report does not include the descriptions of Protection, Control, and Telecommunications requirements and the associated upgrade scopes; however, as discussed in Section 2 “Purpose and Scopes of Study”, the associated cost implications are captured and delivered in the cover letter to the IC.

Contents

Executive Summary	vi
1 Introduction	1
2 Purpose and Scopes of Study	3
3 Standard and Criteria	4
4 Assumptions and Conditions	5
5 System Studies and Results	6
5.1 Power Flow Study Results	6
5.1.1 Thermal Overload Analysis	6
5.1.2 Steady-State Voltage Analysis	7
5.1.3 Reactive Power Capability Evaluation	7
5.1.4 Anti-Islanding Requirements	7
5.1.5 Other Performance Requirements	8
5.2 Fault Analysis	8
5.3 Stations Requirements	8
6 Cost Estimate and Schedule	10
7 Conclusions	11

Appendices

Appendix A	Schematic Diagram of the IC's Project
Appendix B	Power Flow Study Results
Appendix C	One-Line Sketch for the Switching Station

Acronyms

The following are acronyms used in this report.

BCH	BC Hydro
BMT	Bear Mountain Terminal
CEAP	Competitive Electricity Acquisition Process
COD	Commercial Operation Date
DTT	Direct Transfer Trip
EGB	East Groundbirch
ERIS	Energy Resource Interconnection Service
ET3	Cutbank Ridge Partnership- Tower 03/07 Substation
IBR	Inverter-Based Resources
IC	Interconnection Customer
IS	In-Service Date
IR	Interconnection Request
GMS	Gordon M. Shrum G.S.
LAPS	Local Area Protection Schemes
MPO	Maximum Power Output
NERC	North American Electric Reliability Corporation
NRIS	Network Resource Interconnection Service
OATT	Open Access Transmission Tariff
POI	Point of Interconnection
PRES	Peace Region Electric Supply
PLD	ARC Resources Ltd. Parkland Substation
RAS	Remedial Action Scheme
SGB	Shell Groundbirch Substation
TIR	BC Hydro “60 kV to 500 kV Technical Interconnection Requirements for Power Generators”
TVC	Transmission Voltage Customer
VIC	Virtual Inertia Control
WECC	Western Electricity Coordinating Council
WTG	Wind Turbine Generator

segregated into two new circuits, referred to as: 2L333 (SGB-EGB) and 2L334 (EGB-BMT).

The Peace Region transmission system consists of 230 kV and 138 kV transmission infrastructures supplied from Gordon M. Shrum Generating Station (GMS) and South Bank (SBK) substations, which are the major source of supply to the Peace Region transmission system. Figure 1-1 shows the Peace region transmission system diagram.

The Dawson Creek-Groudbirch area is supplied from SGB via two 230 kV lines and multiple radial 138 kV transmission lines, which interconnecting with the two major BC Hydro substations, Bear Mountain Terminal (BMT) and Dawson Creek (DAW) substation, serving major oil and gas customer loads. SGB is fed by 230 kV Peace Region Electric Supply project (PRES) lines from South Bank substation and the other 230 kV lines 2L340 & 2L342 with power sourced from GMS.

There are two new wind farms, [REDACTED] and [REDACTED] wind with installed capacity of 200 MW each, to be added in the Peace region, which are the [REDACTED]. In addition, one wind farm with 56 MW installed capacity will be added in the Peace Region, [REDACTED]. [REDACTED] is connected to the planned BC Hydro 230 kV switching station, EGB, located in the south portion of the Peace Regional System. The wind farms and connection are shown in Figure 1-1 below.

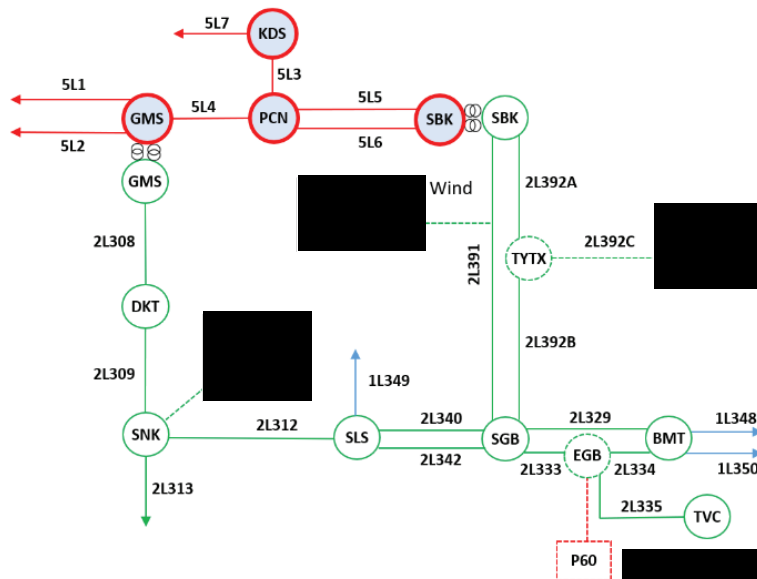

Figure 1-1: Peace Region Transmission System Diagram

2 Purpose and Scopes of Study

This Feasibility Study is a preliminary evaluation of the system impact of interconnecting the proposed project to the BCH system based on power flow and short circuit analysis in accordance with BCH's Open Access Transmission Tariff (OATT) and produces the estimated cost of required Network Upgrades and the implementation schedule.

Per OATT, the Feasibility Study is performed individually for each of the participating projects in the CEAP process and focuses specifically on the BC Hydro regional transmission system where the proposed generating project is connected and affects.

This is a "limited scope" study which is restricted to power flow studies of P0, P1 and P2 planning events as defined in TPL-001-4 and short circuit analysis. The study does not address other technical aspects such as transient stability and switching transients and impact of multiple contingencies. These subjects will be addressed in subsequent System Impact Study (SIS) if the project proceeds further. In addition, any potential impacts to the adjacent external systems to BCH would be addressed in subsequent detailed and coordinated studies with the relevant adjacent entities if the proposed generator project proceeds further.

Please note that, due to the compressed study timeline for CEAP 2025 Feasibility Studies, this report does not include the descriptions of the Protection, Control, and Telecommunication requirements and the associated upgrade scopes. Instead, the network upgrades associated with Protections, Controls and Telecommunications are incorporated with cost estimates in a separate cover letter to the IC.

3 Standard and Criteria

The Feasibility Study is performed in compliance with the North American Electric Reliability Corporation (NERC) and Western Electricity Coordinating Council (WECC) reliability standards, and the BCH interconnection requirements in the TIR, and upon the ratings of the existing BCH transmission facilities described in Operating Orders, specifically:

- NERC standards: TPL-001-4 and FAC-002-3 relevant to the scope of this Feasibility Study.
- WECC criteria TPL-001-WECC-CRT-4 Transmission System Planning Performance, July 1, 2023.
- BC Hydro's 60 kV to 500 kV Technical Interconnection Requirements for Power Generators, Rev 2.1.1, Effective: Sept 22, 2025.
- BC Hydro Operating Order 5T-10, Ratings for All Transmission Circuits 60 kV or Higher, Sept 17, 2025.
- BC Hydro Operating Order 5T-14, Ratings for All Transmission and Distribution Transformer, Sept 22, 2025.
- BC Hydro System Operating Order 7T-22 System Voltage Control, Sept 19, 2023.

4 Assumptions and Conditions

This Feasibility Study is performed based on the IC's submitted data and information available to BCH on Oct 14, 2025, for the study purpose. Assumptions are made wherever the IC's input is unavailable. Appendix A shows the schematic diagram of the IC's project used in the study model.

The power flow study cases used in this Feasibility Study are established based upon the BCH base resource plan and load forecasts available at the time of performing the study, which includes existing and future generators, transmission facilities, and loads in addition to the subject interconnection project in this study. Applicable seasonal conditions and the appropriate study years for the study planning horizon are also incorporated. Additional assumptions are listed as follows.

- 1) The generation in the Peace region are dispatched at Maximum Power Outputs (MPO) to stress the transmission system in the Peace area, unless otherwise specified.
- 2) The 2024 Distribution Substation Load Forecast, 2025 Transmission Voltage Customer (TVC) Load Forecast and 2025 System Peak Forecast are used.
- 3) September 2024 Base Resource Plan
- 4) 200 MW ██████████ will be in service on September 30, 2031, and 200MW ██████████ will be in service on October 1, 2030.
- 5) A new 56 MW Wind project will be in service on October 31, 2028.
- 6) 29HW, 30HS, 30LS, 32HS and 32LS are used as base case in the study to evaluate system impact after █████ █████ █████ █████ plant interconnection.
- 7) The Bear Mountain Terminal T4 will be in service by March 2027.
- 8) 1L377 normally open between ARC Resources Ltd. Parkland Substation (PLD) and Cutbank Ridge Partnership- Tower 03/07 Substation (ET3)
- 9) All BCH TVC load interconnection and associated system reinforcement are modeled in this study.

5 System Studies and Results

Based upon the IC's submitted information and the area system conditions, it is recommended that the proposed POI be changed to the switching station EGB, which is currently under construction, on 230kV line 2L333. This connection is necessary to ensure system reliability and provide adequate protection performance for the new generation interconnection while continuing to serve existing customers.

5.1 Power Flow Study Results

Power flow studies were performed to evaluate whether the IC's generating project would cause any unacceptable system performance (e.g. equipment overloads, steady-state voltage violation and voltage instability) and to determine the system reinforcement requirement based on steady state performance analysis.

The study focuses on the base scenarios – 32HS/32LS system conditions that include all the higher-queued generating projects (██████████, ██████, and generating queue Wind) in the Peace region. These base cases were prepared based on factors such as load conditions, seasonal variation in ambient temperatures, and generation patterns that stress the transmission system.

In addition to the base scenario, an additional scenario is studied for the first year after the ██████████ enters service (29HW/30HS/30LS).

The studies are performed for system normal conditions and under critical system contingencies specified in the P1 and P2 events by NERC TPL-001-4. Study results are summarized below.

5.1.1 Thermal Overload Analysis

For all the studied scenarios (29HW, 30LS, 30HS, 32LS and 32HS), the study shows that the addition of ██████████ would not cause any thermal overloads under system normal conditions.

Under single contingency conditions, regional thermal overloads were observed on 230 kV line 2L308 and GMS 500/230 kV transformers T13 or T14, while bulk system thermal overloads were identified on 500 kV lines 5L1, 5L2 and 5L3. Currently, these overloads are mitigated by the Peace Area Wind Farm Generation

Shedding Remedial Action Scheme (RAS) and the G.M. Shrum Area Generation Shedding RAS, respectively. As a result, the ██████████ will be required to participate in and modify the existing Peace Area Wind Farm Gen Shedding RAS and participate in the G.M. Shrum Area Gen Shedding RAS. The detailed RAS requirements will be confirmed during the SIS stage, if necessary.

Details of the thermal overload analysis are provided in Appendix B.

5.1.2 Steady-State Voltage Analysis

With the connection of the IC's project, the steady-state voltage performance under system normal and single contingency conditions is acceptable for all the studied scenarios (29HW, 30HS, 30LS, 32HS and 32LS). Appendix B shows the details in the steady-state voltage study results.

5.1.3 Reactive Power Capability Evaluation

The BCH TIR requires IBR power plant to have the dynamic reactive power capability at a minimum of +/- 33% of its MPO at the high voltage side of the IC's switchyard over the full MW operating range.

Based on the IC-submitted PSS/E model data, the proposed ██████████ does not meet the requirement above, which needs to be addressed if the project proceeds to the next stage of the interconnection process.

In addition, according to the IC-provided reactive capability data, the proposed WTG would provide +/-1.7 MVAR reactive capability at the zero MW output if the turbine's "STATCOM" function is enabled. This function needs to be re-confirmed if the IC's project proceeds to next stage of the interconnection process.

5.1.4 Anti-Islanding Requirements

██████████ is not arranged for islanded operation. In addition, the IC is required to install anti-islanding protection within its facility to disconnect the IC's wind farm from the grid when an inadvertent island with the local load forms.

A Direct Transfer Trip (DTT) protection scheme is required to isolate the IC's wind project at the IC's entrance circuit breaker to avoid potential islanding operations with the existing loads.

5.1.5 Other Performance Requirements

Fast Frequency Response, also known as Virtual Inertia Control (VIC) in the proposed wind turbines, is required at the ██████████. The proposed wind turbine generators, when equipped with the VIC option, are expected to temporarily boost the MW output to limit the system frequency drop during a major frequency event. The VIC settings should be determined in coordination with BC Hydro in the later stage of the interconnection process.

5.2 Fault Analysis

The short circuit analysis in the Feasibility Study is based upon the latest BC Hydro system model, which includes the generating facility information and associated impedance data provided by the IC. A more detailed study will be performed at the system impact study stage if needed.

5.3 Stations Requirements

The scope of work at EGB is summarized below.

- Add two, new 230 kV circuit breakers 2CB1 and 2CB5 with associated disconnects to expand the 230 kV three-circuit breaker ring bus to a five-circuit breaker ring bus. The purpose of adding 2CB1 is to enable the relocation of line 2L333 to satisfy the functional requirements identified by Transmission Planning.
- Remove 2L333 connection with bus 2B3 and temporarily re-terminate it on bus 2B1 between 2CB10 and 2CB1.
- Add a new 230 kV line terminal with associated disconnect, surge arrester and capacitor voltage transformer between 2CB5 and 2CB10.
- Terminate ██████████ 230 kV transmission line (temporarily designated as 2LXXX) at the new line terminal, if required. Project team to confirm in the future stage.
- Other associated station work.
- Expand the control building, if required, to accommodate new P&C panels and other equipment.

- Expand the existing station fence within the property line to accommodate the above additional facilities.

The station planning study is based on the following assumptions:

1. Coordination with the EGB switching station construction project may be needed.
2. The EGB configuration will be confirmed by Design Engineering and the future configuration may be revised to accommodate evolving requirements.

Refer to the one-line diagram Appendix C for details.

6 Cost Estimate and Schedule

The non-binding good faith estimated cost and time to construct the Network Upgrades required to interconnect the proposed project will be provided in a separate letter to the IC.

7 Conclusions

To interconnect the ██████████ and its facilities to the BCH Transmission System at the POI, this Feasibility Study has identified the following conclusions and requirements:

1. The proposed POI, a tap structure on the 2L333 is not acceptable to interconnect the customer's generating project to BCH transmission system. Instead, it is recommended that the POI be changed to the 230 kV bus of the planned East Groundbirch switching station, which will loop in the existing line 2L333 and is located approximately 14 km from the SGB. The EGB switching station is being built to support a TVC interconnection request and is currently in the construction phase.
2. No thermal overload or voltage constraints have been identified under system normal conditions.
3. Under single contingency conditions, regional thermal overloads were identified on 230 kV line 2L308 and GMS 500/230 kV transformers T13 or T14, while bulk system thermal overloads were identified on 500 kV lines 5L1, 5L2 and 5L3. Currently, these overloads are mitigated by the Peace Area Wind Farm Generation Shedding RAS and the G.M. Shrum Area Generation Shedding RAS, respectively. As a result, the ██████████ will be required to participate in and modify the existing Peace Area Wind Farm Gen Shedding RAS and participate in the G.M. Shrum Area Gen Shedding RAS. The RAS function scope will be specified in the System Impact Study if the need for RAS is determined.
4. ██████████ is required to install anti-islanding protection within its facility to disconnect the IC's generating plant from the grid when an inadvertent island with the local load forms. The anti-islanding protection shall be configured in the manner that does not compromise the required ride-through performance.
5. A DTT protection scheme is required to isolate the IC's wind project at the IC's entrance circuit breaker to avoid potential islanding operations with the existing loads.

6. The ██████████ is required to have the dynamic reactive power capability at a minimum of +/- 33% of its MPO at the high voltage side of the IC's switchyard over the full MW operating range, per BC Hydro's TIR Section 6.4.2. Based on the IC-submitted PSS/E model, the proposed ██████████ does not meet the reactive capability requirement above.
7. The "STATCOM option" for ██████████ type-3 WTGs is required so that each turbine can provide reactive power capability at zero MW output. BC Hydro recognizes that Type-3 WTGs with the STATCOM option have an inherent limitation—providing only partial reactive power capability during turbine standstill.
8. Fast Frequency Response, also known as Virtual Inertia Control (VIC) in ██████████ wind turbines, is required at the ██████████. The proposed wind turbine generators, when equipped with the VIC option, are expected to temporarily boost the MW output to limit the system frequency drop during a major frequency event. The VIC settings should be determined in coordination with BC Hydro in the later stage of the interconnection process.

Appendix A

Schematic Diagram of the IC's Project

Figure A-1 shows the schematic diagram for the [redacted].

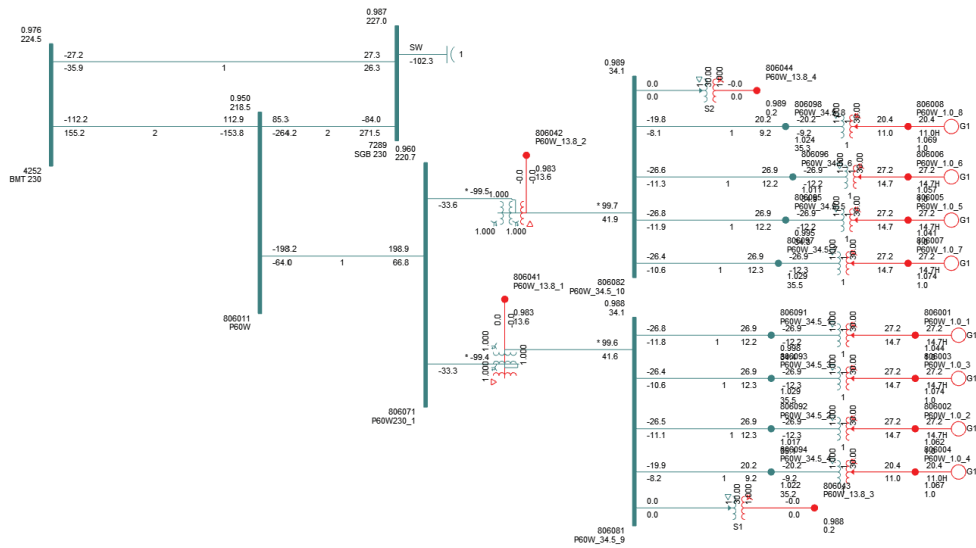

Figure A-1: [redacted] Plant Schematic Diagram.

Appendix B

Power Flow Study Results

Table B-1: Thermal Overload Study Results

Cases	IC's Gen Output (MW)	Contingency		Branch Loading (Amps/MVA)				
				2L308	2L312	5L1	GMS T14	SBK T22
		Cate.	Description	GMS-DKT	SNK-SLS	GMS-WSN	(MVA)	(MVA)
Winter Ratings				1359	1351	3444	356	714
29HW	Max	P0	System Normal	683.8 50.3%	587.8 43.5%	1584.4 52.8%	126.3 35.5%	53.9 7.6%
		P1	2L308	N/A	1270.9 94.1%	1575.0 52.5%	12.9 3.6%	171.4 24.0%
		P1	BMT_T4	683.8 50.3%	587.8 43.5%	1584.4 52.8%	126.3 35.5%	53.9 7.6%
		P1	GMS_T13	620.7 45.7%	651.0 48.2%	1584.3 52.8%	228.2 64.1%	65.0 9.1%
		P1	SBK_T21	698.5 51.4%	572.6 42.4%	1584.6 52.8%	129.2 36.3%	99.2 13.9%
		P1	5L3	729.3 53.7%	554.9 41.1%	2434.8 81.2%	133.9 37.6%	43.9 6.2%
		P1	5L4	752.7 55.4%	518.6 38.4%	1484.6 49.5%	140.0 39.3%	35.6 5.0%
		P1	2L392	714.9 52.6%	555.5 41.1%	1584.9 52.8%	132.5 37.2%	45.3 6.3%
		P2	SBK_2CB21	725.4 53.4%	544.7 40.3%	1585.0 52.8%	134.6 37.8%	84.4 11.8%
		P2	GMS_1CB4	626.3 46.1%	644.1 47.7%	1607.6 53.6%	230.4 64.7%	68.1 9.5%
		P2	SGB_2CB2	714.9 52.6%	555.5 41.1%	1584.9 52.8%	132.5 37.2%	45.3 6.3%
		P2	SLS_2CB21	728.3 53.6%	540.0 40.0%	1584.0 52.8%	135.1 38.0%	66.2 9.3%
		Summer Ratings				1073	1066	2244
30HS	Max	P0	System Normal	730.3 68.1%	577.6 54.2%	1691.7 75.4%	127.6 42.5%	69.2 11.5%
		P1	2L308	N/A	1308.7 122.8%	1681.9 75.0%	19.5 6.5%	193.9 32.3%
		P1	BMT_T4	730.2 68.1%	577.7 54.2%	1691.6 75.4%	127.5 42.5%	69.0 11.5%
		P1	GMS_T13	666.6 62.1%	640.9 60.1%	1691.4 75.4%	231.1 77.0%	80.2 13.4%
		P1	SBK_T21	748.9 69.8%	558.6 52.4%	1691.9 75.4%	131.2 43.7%	126.8 21.1%
		P1	5L3	778.5 72.6%	544.1 51.0%	2610.7 116.3%	134.9 45.0%	58.2 9.7%
		P1	5L4	792.3 73.8%	516.1 48.4%	1602.0 71.4%	139.5 46.5%	52.9 8.8%
		P1	2L392	770.5 71.8%	536.5 50.3%	1692.2 75.4%	135.4 45.1%	57.7 9.6%
		P2	SBK_2CB21	783.7 73.0%	523.1 49.1%	1692.3 75.4%	138.0 46.0%	107.4 17.9%

		P2	GMS_1CB4	671.3 62.6%	636.8 59.7%	1710.1 76.2%	232.8 77.6%	81.6 13.6%		
		P2	SGB_2CB2	770.5 71.8%	536.5 50.3%	1692.2 75.4%	135.4 45.1%	57.7 9.6%		
		P2	SLS_2CB21	771.5 71.9%	535.1 50.2%	1691.0 75.4%	135.6 45.2%	78.5 13.1%		
30LS	Max	P0	System Normal	779.6 72.7%	525.7 49.3%	1660.7 74.0%	141.5 47.2%	97.3 16.2%		
		P1	2L308	N/A	1307.8 122.7%	1649.8 73.5%	16.0 5.3%	231.1 38.5%		
		P1	BMT_T4	779.5 72.6%	526.0 49.3%	1660.6 74.0%	141.5 47.2%	97.2 16.2%		
		P1	GMS_T13	709.5 66.1%	596.2 55.9%	1660.4 74.0%	256.1 85.4%	109.7 18.3%		
		P1	SBK_T21	806.3 75.1%	498.6 46.8%	1661.0 74.0%	146.7 48.9%	178.9 29.8%		
		P1	5L3	826.2 77.0%	492.4 46.2%	2562.2 114.2%	148.6 49.5%	86.7 14.4%		
		P1	5L4	873.4 81.4%	432.6 40.6%	1525.0 68.0%	159.6 53.2%	72.3 12.0%		
		P1	2L392	836.5 78.0%	468.0 43.9%	1661.4 74.0%	152.5 50.8%	81.5 13.6%		
		P2	SBK_2CB21	855.6 79.7%	448.8 42.1%	1661.7 74.0%	156.2 52.1%	151.8 25.3%		
		P2	GMS_1CB4	714.2 66.6%	591.8 55.5%	1675.8 74.7%	258.0 86.0%	111.1 18.5%		
		P2	SGB_2CB2	836.5 78.0%	468.0 43.9%	1661.4 74.0%	152.5 50.8%	81.5 13.6%		
		P2	SLS_2CB21	823.4 76.7%	480.4 45.1%	1660.0 74.0%	150.0 50.0%	109.0 18.2%		
		32HS	Max	P0	System Normal	854.9 79.7%	450.7 42.3%	1716.5 76.5%	150.4 50.1%	193.7 32.3%
				P1	2L308	N/A	1308.0 122.7%	1704.2 75.9%	21.5 7.2%	339.2 56.5%
P1	BMT_T4			854.8 79.7%	451.1 42.3%	1716.4 76.5%	150.4 50.1%	193.7 32.3%		
P1	GMS_T13			780.8 72.8%	525.7 49.3%	1716.1 76.5%	272.3 90.8%	206.9 34.5%		
P1	SBK_T21			909.0 84.7%	396.8 37.2%	1717.3 76.5%	160.9 53.6%	357.3 59.5%		
P1	5L3			902.9 84.1%	417.0 39.1%	2642.8 117.8%	157.6 52.5%	183.5 30.6%		
P1	5L4			978.5 91.2%	329.9 30.9%	1538.4 68.6%	174.2 58.1%	161.1 26.9%		
P1	2L392A			988.1 92.1%	318.9 29.9%	1717.8 76.6%	176.3 58.8%	156.5 26.1%		
P1	2L392B			875.9 81.6%	428.6 40.2%	1717.0 76.5%	154.4 51.5%	188.3 31.4%		
P2	SBK_2CB21			1025.1 95.5%	286.3 26.9%	1718.4 76.6%	183.5 61.2%	291.4 48.6%		
P2	GMS_1CB4			785.4 73.2%	521.9 49.0%	1734.0 77.3%	273.9 91.3%	208.1 34.7%		
P2	SGB_2CB2			875.4 81.6%	430.9 40.4%	1716.9 76.5%	154.4 51.5%	188.2 31.4%		
P2	SLS_2CB21			906.1 84.4%	398.0 37.3%	1715.7 76.5%	160.4 53.5%	210.6 35.1%		
32LS	Max			P0	System Normal	908.4 84.7%	397.8 37.3%	1769.8 78.9%	165.1 55.0%	228.2 38.0%

	P1	2L308	N/A	1307.8 122.7%	1756.6 78.3%	17.5 5.8%	382.7 63.8%
	P1	BMT_T4	908.3 84.6%	398.3 37.4%	1769.8 78.9%	165.1 55.0%	228.2 38.0%
	P1	GMS_T13	827.1 77.1%	480.2 45.1%	1769.4 78.8%	298.9 99.6%	242.7 40.4%
	P1	SBK_T21	972.4 90.6%	334.6 31.4%	1770.8 78.9%	177.5 59.2%	420.9 70.2%
	P1	5L3	958.8 89.4%	364.4 34.2%	2735.8 121.9%	172.4 57.5%	217.7 36.3%
	P1	5L4	1047.1 97.6%	263.9 24.8%	1570.8 70.0%	191.7 63.9%	191.7 31.9%
	P1	2L392A	1059.0 99.0%	251.1 23.6%	1771.1 78.9%	194.1 64.7%	185.9 31.0%
	P1	2L392B	946.5 88.2%	358.6 33.6%	1770.4 78.9%	172.5 57.5%	218.0 36.3%
	P2	SBK_2CB21	1103.6 102.8%	208.8 19.6%	1771.5 78.9%	202.7 67.6%	346.4 57.7%
	P2	GMS_1CB4	832.0 77.5%	476.1 44.7%	1784.6 79.5%	300.6 100.2%	243.9 40.7%
	P2	SGB_2CB2	946.5 88.2%	358.6 33.6%	1770.4 78.9%	172.5 57.5%	218.0 36.3%
	P2	SLS_2CB21	962.2 89.7%	342.5 32.1%	1768.9 78.8%	175.6 58.5%	247.5 41.3%

Table B-2: Steady-State Voltage Study Results

Case	IC's Generator Output	Contingency		Bus Voltage (PU)	
		Cate-gory	Description	SGB 230	BMT 230
29HW	Max	P0	System Normal	1.022	1.024
		P1	GMS_T13	1.021	1.023
		P1	2L308	1.013	1.017
		P2	SBK_2CB21	1.019	1.022
30HS	Max	P0	System Normal	1.022	1.024
		P1	GMS_T13	1.021	1.024
		P1	2L308	1.014	1.022
		P2	SBK_2CB21	1.020	1.023
30LS	Max	P0	System Normal	1.025	1.026
		P1	GMS_T13	1.024	1.026
		P1	2L308	1.016	1.023
		P2	SBK_2CB21	1.023	1.026
32HS	Max	P0	System Normal	1.028	1.027
		P1	GMS_T13	1.027	1.027
		P1	2L308	1.021	1.025
		P2	SBK_2CB21	1.027	1.027
32LS	Max	P0	System Normal	1.029	1.027
		P1	GMS_T13	1.028	1.027
		P1	2L308	1.020	1.025
		P2	SBK_2CB21	1.028	1.027

Appendix C

One-Line Sketch for the Switching Station

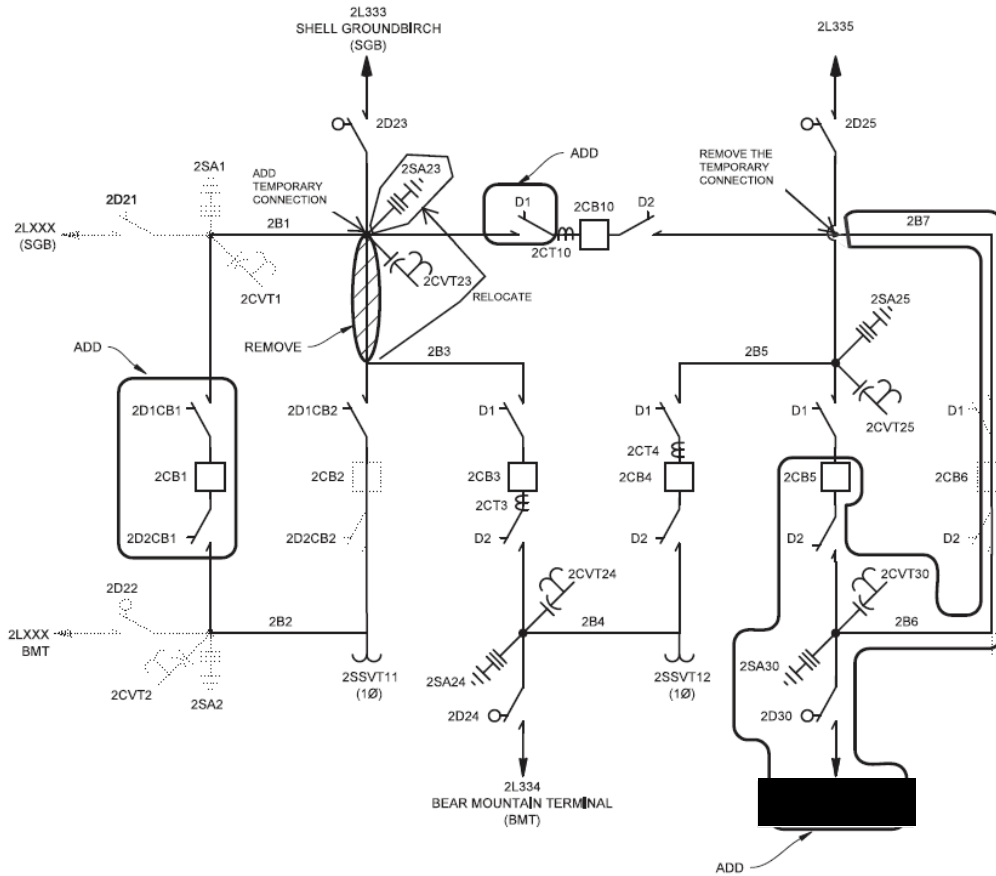

Figure C-1: Stations Planning One-Line Sketch for the Switching Station EGB.