

6911 Southpoint Drive (B03)
Burnaby, BC
V3N 4X8

November 24, 2025

[REDACTED]
[REDACTED]
[REDACTED]
[REDACTED]

via email: [REDACTED]

RE: CEAP IR #43 – [REDACTED] –
Interconnection Feasibility Study

Dear [REDACTED]

Enclosed is the Interconnection Feasibility Study for the proposed Interconnection Request (IR), [REDACTED], submitted under Attachment M-2: Transmission Service and Interconnection Service Procedures for Competitive Electricity Acquisition Process (CEAP) of the Open Access Transmission Tariff (OATT). This letter provides a non-binding good faith estimate of the cost and time to construct the facilities required to interconnect your project to BC Hydro's Transmission System, being the Network Upgrades, based on the findings of the Interconnection Feasibility Study.

Open Access Transmission Tariff

The OATT defines Network Upgrades as additions, modifications, and upgrades to BC Hydro's Transmission System required at or beyond the Point of Interconnection (POI) to accommodate the interconnection of the Generating Facility to the BC Hydro's Transmission System. Pursuant to the OATT, BC Hydro will design, procure, construct, install, and own the Network Upgrades. While BC Hydro will pay the costs for the Network Upgrades, the Interconnection Customer provides security for such costs.

Interconnection Study Costs

The Interconnection Customer is responsible for paying the full cost of all Interconnection Studies in cash. Interconnection Study costs vary depending on the scope, complexity, and other factors such as whether any scope is shared with another Interconnection Customer (not applicable to this Interconnection Feasibility Study). The deposit amounts specified in the OATT are not proxy Interconnection Study costs. If actual Interconnection Study costs exceed the deposit amount, the Interconnection Customer must pay the remaining balance in cash. Please refer to the answer for question no. 53 in the posted [Questions & Answers for 2025 Call for Power](#) for typical study cost ranges.

Cost Estimate

Based on the Interconnection Feasibility Study, the non-binding good faith estimated cost (typical accuracy range of +150%/-50%) for Network Upgrades required to interconnect your project is \$41.2 M.

Major Scope of Work Identified:

- Add one 230kV line position and terminate the customer's line with associated equipment including two circuit breakers and disconnect switches at BC Hydro's Glenannan Substation (GLN)
- Extend 230 kV existing 2M2 main bus to facilitate new 230 kV line position

- Add one line terminal for [REDACTED] line including motor operated disconnect switch, surge arrester, and capacitor voltage transformer
- Upgrade required substation facilities, infrastructures, and bus work to support new station equipment
- Supply and install required Protection, Control and Telecommunications equipment

Exclusions:

- GST
- Permits
- Right-of-Way & property costs

Key Assumptions:

- Construction by contractor
- 8 months of construction is considered
- No construction during winter season
- Execution of early Engineering and Procurement Agreement
- No expansion of existing stations or control buildings to accommodate new equipment
- Impact Benefit Agreements with First Nations are not considered

Key Risks:

- Expansion of the existing control building may be required leading to increased costs and/or a longer project schedule
- Major equipment delivery presents potential project cost and schedule risks, based on variance in equipment lead times
- No defined supply chain strategy; construction costs may increase depending on delivery method
- Project schedule may be longer than expected, leading to increased overhead costs
- Ground improvements may be required leading to increased construction costs
- Contaminated soil may be encountered leading to increased construction costs
- Cost of materials and major equipment may be affected by market conditions and escalation

Study Limitations and Exclusions***Protection, Control, and Telecommunications***

The Interconnection Feasibility Study does not include a detailed review of the protection, control, and telecommunications system requirements specific to your Interconnection Request. Based on a high-level review, we have identified proxy costs for protection, control, and telecom Network Upgrades drawn from comparable interconnection projects with similar scope and complexity; these proxy costs have been included solely for indicative budgeting purposes. The relative interconnection cost determined by the Interconnection Feasibility Study includes a telecommunications component based on an assumed solution to deliver teleprotection and telecontrol circuit requirements necessary for the Interconnection Request. Protection, control, and telecommunications system requirements will be reviewed in detail in the System Impact Study if you are a successful participant of the CEAP and meet applicable requirements.

For Interconnection Feasibility Study purposes, it is assumed that any applicant-proposed works that could obstruct or impair the performance of existing BC Hydro microwave systems or new links from the proposed

Interconnection Customer Interconnection Facilities (ICIF) to the BC Hydro microwave system would be identified and either relocated or repositioned as determined in a System Impact Study if you are a successful participant of the CEAP and meet applicable requirements. Such works may include, but are not limited to, towers, turbines, dams, support structures, panels, surface materials deposited or redistributed, water surface changes, or vegetation.

Generation Shedding/Curtailment Scheme and Electromagnetic Transient (EMT) Studies

The generation shedding/curtailment scheme reviews (e.g., Remedial Action Scheme (RAS), and a direct transfer trip for anti-islanding scheme) and EMT studies are completed in a System Impact Study. The outcomes of these studies may result in additional requirements, which could include Network Upgrades or ICIF. Any costs associated with completion of these studies, and resulting requirements, are not included in the Interconnection Feasibility Study cost estimate.

Revenue Metering

Please note that revenue metering requirements have not been determined with the Interconnection Feasibility Study. As such, any costs associated with revenue metering and other interconnection components are not included in the cost estimate provided above. Once these requirements are defined, costs that are attributable to the Interconnection Customer are to be paid in cash. For more details on revenue metering requirements and responsibilities, please refer to:

<https://www.bchydro.com/content/dam/BCHydro/customer-portal/documents/distribution/standards/ds-rmr-complex-revenue-metering.pdf>.

Schedule

Based on the Interconnection Feasibility Study, the non-binding good faith estimated in-service date for your Interconnection Request's Network Upgrades is Quarter 4 2032 (calendar year). To achieve this timeline, we may need to expedite certain activities, including engineering design and procurement of long-lead equipment.

Timely actions required from you to minimize risks to the schedule:

- Submission of additional technical data required for the System Impact Study and Facilities Study
- Submission of any required information or document such as demonstration of Site Control
- Execution of Combined Study Agreement and Standard Generator Interconnection Agreement
- Financial commitments and securities

Since your proposed POI is located within the North Coast Transmission Line Region, the interconnection of your IR has been determined, at this time, to be dependent upon the completion of the North Coast Transmission Line (NCTL) project.

Accordingly, please note the 2025 Call for Power Addendum 5 and revised Specimen EPA specify that the Guaranteed Commercial Operation Date for a project which is dependent upon the completion of NCTL will be October 1, 2033, notwithstanding that the Interconnection Feasibility Study report may indicate an earlier date.

Please note that changes to your IR or delays in data submission or financial commitments may also impact the target in-service date. Please note that changes to your Interconnection Request or delays in data submission or financial commitments may also impact the target in-service date.

If you have any questions, please contact the BC Hydro CEAP team at ceap2025@bchydro.com.

Sincerely,

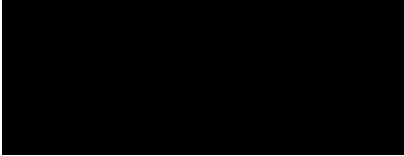

Manager, Customer Interconnections

BC Hydro

Encl.: CEAP_2025_IR43_  Feasibility_Study.pdf



Interconnection Feasibility Study

BC Hydro EGBC Permit to Practice No: 1002449

2025 CEAP IR # 43

Prepared for:



Prepared by:

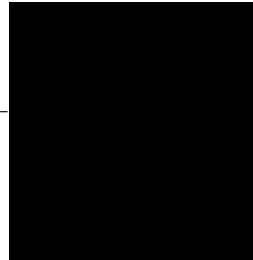
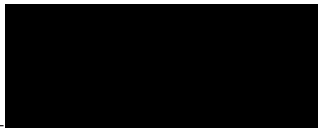

Specialist Engineer, Transmission
Planning

Reviewed by:



Principal Engineer, Transmission Planning

Accepted by:



Manager, Transmission Planning

Report Metadata

Header: 2025 CEAP IR # 43
Subheader: Interconnection Feasibility Study
Title: [REDACTED]
Subtitle: 2025 CEAP IR # 43
Report Number: 900-APR-00032
Revision: 0
Confidentiality: Public
Date: 2025 Nov 21
Volume: 1 of 1

Prepared for: [REDACTED]
Prepared by: [REDACTED]
Title: Specialist Engineer, Transmission Planning
Checked by: [REDACTED]
Title: Specialist Engineer, Transmission Planning
Reviewed by: [REDACTED]
Title: Principal Engineer, Transmission Planning

Related Facilities: GLN
Additional Metadata: Transmission Planning 2025-077
Filing Subcode 1350

Revisions

Revision	Date	Description
0	2025 Nov	Initial release

Disclaimer of Warranty, Limitation of Liability

This report was prepared solely for internal purposes. All parties other than BC Hydro are third parties.

BC Hydro does not represent, guarantee or warrant to any third party, either expressly or by implication:

any information, product or process disclosed, described or recommended in this report.

BC Hydro does not accept any liability of any kind arising in any way out of the use by a third party of any information, product or process disclosed, described or recommended in this report, nor does BC Hydro accept any liability arising out of reliance by a third party upon any information, statements or recommendations contained in this report. Should third parties use or rely on any information, product or process disclosed, described or recommended in this report, they do so entirely at their own risk.

This report was prepared by the British Columbia Hydro And Power Authority ("BCH") or, as the case may be, on behalf of BCH by persons or entities including, without limitation, persons or entities who are or were employees, agents, consultants, contractors, subcontractors, professional advisers or representatives of, or to, BCH (individually and collectively, "BCH Personnel").

This report is to be read in the context of the methodology, procedures and techniques used, BCH's or BCH's Personnel's assumptions, and the circumstances and constraints under which BCH's mandate to prepare this report was performed. This report is written solely for the purpose expressly stated in this report, and for the sole and exclusive benefit of the person or entity who directly engaged BCH to prepare this report. Accordingly, this report is suitable only for such purpose, and is subject to any changes arising after the date of this report. This report is meant to be read as a whole, and accordingly no section or part of it should be read or relied upon out of context.

Unless otherwise expressly agreed by BCH:

- (a) any assumption, data or information (whether embodied in tangible or electronic form) supplied by, or gathered from, any source (including, without limitation, any consultant, contractor or subcontractor, testing laboratory and equipment suppliers, etc.) upon which BCH's opinion or conclusion as set out in this report is based (individually and collectively, "Information") has not been verified by BCH or BCH's Personnel; BCH makes no representation as to its accuracy or completeness and disclaims all liability with respect to the Information;
- (b) except as expressly set out in this report, all terms, conditions, warranties, representations and statements (whether express, implied, written, oral, collateral, statutory or otherwise) are excluded to the maximum extent permitted by law and, to the extent they cannot be excluded, BCH disclaims all liability in relation to them to the maximum extent permitted by law;
- (c) BCH does not represent or warrant the accuracy, completeness, merchantability, fitness for purpose or usefulness of this report, or any information contained in this report, for use or consideration by any person or entity. In addition, BCH does not accept any liability arising out of reliance by a person or entity on this report, or any information contained in this report, or for any errors or omissions in this report. Any use, reliance or publication by any person or entity of this report or any part of it is at their own risk; and
- (d) In no event will BCH or BCH's Personnel be liable to any recipient of this report for any damage, loss, cost, expense, injury or other liability that arises out of or in connection with this report including, without limitation, any indirect, special, incidental, punitive or consequential loss, liability or damage of any kind.

Copyright Notice

Copyright and all other intellectual property rights in, and to, this report are the property of, and are expressly reserved to, BCH. Without the prior written approval of BCH, no part of this report may be reproduced, used or distributed in any manner or form whatsoever.

Contributors

The following accept responsibility for the content in the specified sections. Professionals apply their signature and/or seal as appropriate.

Section:

Entire report
except listed
below

Discipline:

Transmission Planning

Contributed by:

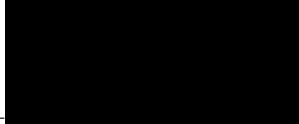

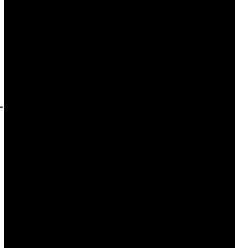
Specialist Engineer, Transmission
Planning 

Section:

5.2, 5.3

Discipline:

Stations Growth and Sustainment

Contributed by:



Senior Engineer, Stations Growth and
Sustainment 

Executive Summary

[REDACTED] the interconnection customer (IC), requests to interconnect its [REDACTED] (2025 CEAP IR # 43) to the BC Hydro (BCH) system. [REDACTED] has sixty-eight (68) [REDACTED] type-3 wind turbine generators with a maximum power injection of 374.8 MW into the BC Hydro system at the proposed Point of Interconnection (POI). The proposed POI is 230 kV bus in Glenannan (GLN) substation. The IC's proposed commercial operation date (COD) is October 31st, 2032.

To interconnect the [REDACTED] and its facilities to the BCH Transmission System at the proposed POI, this Feasibility Study has made the recommendations and conclusions as follow:

1. A new 230 kV line position is required at GLN substation to facilitate the interconnection of [REDACTED]. The 230 kV line position shall have an independent switching and protection zone.
2. The connection of [REDACTED] does not cause any performance violation (i.e. thermal overload, voltage performance violation or voltage stability concern) under system normal and single contingency conditions.
3. The impact on BC Hydro bulk transmission system is not part of the project scope of the feasibility study. However, it should be noted that [REDACTED] is required to participate in the existing BC Hydro generation shedding RAS to address various performance issues for contingencies in BC Hydro's 500 kV transmission system.
4. [REDACTED] is required to install anti-islanding protection within its facility to disconnect the IC's generating plant from the grid when an inadvertent island with the local load forms. The anti-islanding protection shall be configured in the manner that does not compromise the required ride-through performance.

5. The [REDACTED] is required to have the dynamic reactive power capability at a minimum of +/- 33% of its MPO at the high voltage side of the IC's switchyard over the full MW operating range, per BC Hydro's TIR Section 6.4.2.
6. The "STATCOM option" for the proposed type-3 WTGs is required so that each turbine can provide reactive power capability at zero MW output. BC Hydro recognizes that Type-3 WTGs with the STATCOM option have an inherent limitation—providing only partial reactive power capability during turbine standstill.
7. Fast Frequency Response, also known as Virtual Inertia Control (VIC) in the proposed wind turbines, is required at the [REDACTED]. The proposed wind turbine generators, when equipped with the VIC option, are expected to temporarily boost the MW output to limit the system frequency drop during a major frequency event. The VIC settings should be determined in coordination with BC Hydro in the later stage of the interconnection process.

The above conclusions are made based on the IC's input data and study assumptions listed in Section 4, which represent the best available information on October 14, 2025.

A non-binding good faith cost for required network upgrades and estimated schedule for construction are included in a separate letter to the IC.

Please note that, this Feasibility Study report does not include the descriptions of Protection, Control, and Telecommunications requirements and the associated upgrade scopes; however, as discussed in Section 2 "Purpose and Scopes of Study, the associated cost implications are captured and delivered in the cover letter to the IC".

Contents



Executive Summary	vi
1 Introduction	1
2 Purpose and Scopes of Study	4
3 Standard and Criteria	5
4 Assumptions and Conditions	6
5 System Studies and Results	8
5.1 Power Flow Study Results	8
5.1.1 Thermal Overload Analysis	8
5.1.2 Steady-State Voltage Analysis	8
5.1.3 Reactive Power Capability Evaluation	8
5.1.4 Anti-Islanding Requirements	9
5.1.5 Other Performance Requirements	9
5.2 Fault Analysis	9
5.3 Stations Requirements	9
6 Cost Estimate and Schedule	11
7 Conclusions	12

Appendices

Appendix A	Schematic Diagram of the IC's Project
Appendix B	Power Flow Study Results
Appendix C	One-Line Sketch for GLN Substation

Acronyms

The following are acronyms used in this report.

BCH	BC Hydro
BWM	Black Water Mine
CEAP	Competitive Electricity Acquisition Process
COD	Commercial Operation Date
DTT	Direct Transfer Trip
ERIS	Energy Resource Interconnection Service
FeS	Feasibility Study
FGE	Fort St. James Generating Station
FKR	Forrest Kerr Generating Station
GLN	Glenannan Substation
GTTT	Glenannan to Terrace Transmission Project
IBR	Inverter-Based Resources
IC	Interconnection Customer
IPP	Independent Power Producer
IR	Interconnection Request
ISD	In Service Date
KIT	Kitimat Substation
KMO	Kemano Generating Station
MCY	McLymont Creek Generating Station
MPO	Maximum Power Output
NC	North Coast
NERC	North American Electric Reliability Corporation
	
NRIS	Network Resource Interconnection Service
OATT	Open Access Transmission Tariff
PGGT	Prince George to Glenannan Transmission Project
PGTC	Prince George Capacitor Bank Project
PLG	Palling Station
POI	Point of Interconnection
RAS	Remedial Action Scheme

SNV	Saranovich Station
TAC	Tachick Substation
TIR	BC Hydro “60 kV to 500 kV Technical Interconnection Requirements for Power Generators”
TKW	Telkwa Substation
TVC	Transmission Voltage Customer
VIC	Virtual Inertia Control
VOL	Volcano Creek Generating Station
WECC	Western Electricity Coordinating Council
WSN	Williston Substation
WTG	Wind Turbine Generator

1 Introduction

Table 1-1 below summarizes the project reviewed in this Feasibility Study.

Table 1-1 Summary of Project Information

Project Name	[REDACTED]	
Name of Interconnection Customer (IC)	[REDACTED]	
Point of Interconnection (POI)	GLN	
IC's Proposed COD	31 st October 2032	
Type of Interconnection Service	NRIS <input checked="" type="checkbox"/>	ERIS <input type="checkbox"/>
Maximum Power Injection (MW)	374.8 MW (Summer)	374.8 MW (Winter)
Number of Turbines	68 x 5.9 MW WTGs	
Plant Fuel	Wind	

BluEarth Renewables Inc., the interconnection customer (IC), requests to interconnect its [REDACTED] (2025 CEAP IR # 43) to the BC Hydro system. [REDACTED] has sixty-eight (68) [REDACTED] type-3 wind turbine generators with a maximum power injection of 374.8 MW into the BC Hydro system at the POI. The POI is 230 kV bus in Glenannan (GLN) substation. The IC's proposed commercial operation date (COD) is October 31st, 2032.

Figure 1-1 shows the Glenannan (GLN) Regional transmission system diagram. GLN is a major station approximately 175 km from Williston Substation (WSN) located in BC Hydro's North Coast (NC) region. GLN is connected to WSN via 500 kV line 5L61, and it is connected to Telkwa Substation (TKW) via a 500 kV line 5L62. The Williston-Glenannan-Telkwa-Skeena 500 kV transmission system is a radial system starting from WSN, with various IPP generation and customer loads surrounding the series of 500 kV and 230 kV transmission lines, including major loads at Kitimat (KIT), and key regional generation resources such as Kemano (KMO), Forrest Kerr Generating Station (FKR), Volcano Creek Generating Station (VOL), and McLymont Creek Generating Station (MCY). In Figure 1-1, [REDACTED] (2025 CEAP

There are few planned capital projects to reinforce bulk transmission system in NC region, and they are presented below for an information purpose.

- Prince George Capacitor Bank Project (PGTC) is the major capital project under construction, which will add series compensation for 5L61, 5L62, and 5L63 and a new 500KV/230KV transformer at SKA. Scheduled ISD is in Oct. 2027.
- Prince George to Glenannan Transmission Project (PGGT) Project will construct 500 kV line - 5L64 from Williston to Glenannan substation. Scheduled ISD is in Oct. 2030.
- Glenannan to Terrace Transmission Project (GTTT) will construct two 500 kV lines - 5L65 and 5L66 from Glenannan to Skeena substation. Scheduled ISD is in Oct. 2031.
- 5L61/62/63 thermal upgrades project. Scheduled ISD is in Oct. 2031.

There is one new wind farm, [REDACTED] project with a capacity of 205.2 MW to be added in the GLN region. The [REDACTED] project has a COD in October 2030. It is also shown in Figure 1-1 in red.

2 Purpose and Scopes of Study

This Feasibility Study is a preliminary evaluation of the system impact of interconnecting the proposed project to the BC Hydro system based on power flow and short circuit analysis in accordance with BCH's Open Access Transmission Tariff (OATT) and produces the estimated cost of required Network Upgrades and the implementation schedule.

Per OATT, the Feasibility Study is performed individually for each of the participating projects in the CEAP process and focuses specifically on the BC Hydro regional transmission system where the proposed generating project is connected and affects.

This is a "limited scope" study which is restricted to power flow studies of P0, P1 and P2 planning events as defined in TPL-001-4 and short circuit analysis. The study does not address other technical aspects such as transient stability and switching transients and impact of multiple contingencies. These subjects will be addressed in subsequent System Impact Study if the project proceeds further. In addition, any potential impacts to the adjacent external systems to BC Hydro would be addressed in subsequent detailed and coordinated studies with the relevant adjacent entities if the proposed generator project proceeds further.

Please note that, due to the compressed study timeline for 2025 CEAP Feasibility Study, this report does not include the descriptions of the Protection, Control, and Telecommunication requirements and the associated upgrade scopes. Instead, the network upgrades associated with Protections, Controls and Telecommunications are incorporated with cost estimates in a separate cover letter to the IC.

3 Standard and Criteria

The Feasibility Study is performed in compliance with the North American Electric Reliability Corporation (NERC) and Western Electricity Coordinating Council (WECC) reliability standards, and the BCH interconnection requirements in the TIR, and upon the ratings of the existing BCH transmission facilities described in Operating Orders, specifically:

- NERC standards: TPL-001-4 and FAC-002-3 relevant to the scope of this Feasibility Study.
- WECC criteria TPL-001-WECC-CRT-4 Transmission System Planning Performance, July 1, 2023.
- BC Hydro's 60 kV to 500 kV Technical Interconnection Requirements for Power Generators, Rev 2.1.1, Effective: Sept 22, 2025.
- BC Hydro Operating Order 5T-10, Ratings for All Transmission Circuits 60 kV or Higher, Sept 17, 2025.
- BC Hydro Operating Order 5T-14, Ratings for All Transmission and Distribution Transformer, Sept 22, 2025.
- BC Hydro System Operating Order 7T-22 System Voltage Control, Sept 19, 2023.

4 Assumptions and Conditions

This Feasibility Study is performed based on the IC's submitted data and information available to BC Hydro on Oct 14, 2025 for the study purpose. Assumptions are made wherever the IC's input is unavailable. Appendix A shows the schematic diagram of the IC's Project used in the study model.

The power flow study cases used in this Feasibility Study are established based upon the BC Hydro's base resource plan and load forecasts available at the time of performing the study, which includes existing and future generators, transmission facilities, and loads in addition to the subject interconnection project in this study. Applicable seasonal conditions and the appropriate study years for the study planning horizon are also incorporated. Additional assumptions are listed as follows.

- 1) The generation in the study area are dispatched to the patterns that stress the transmission system in the study area. In these patterns, the associated generators are typically set to their Maximum Power Outputs (MPO) unless otherwise specified.
- 2) RTA to BCH power transfer is set to 420 MW to achieve higher power transfer from GLN to WSN.
- 3) There is an ongoing 500 KV transmission reinforcement project: PGTC which includes series compensations on 5L61, 5L62, and 5L63, and a new 500KV/230KV transformer SKA T3. This project will be in service by Oct. 2027, and it has been taken into account in this study.
- 4) There is a planned capital project called PGGT to add a new line 5L64 in parallel with 5L61 connecting GLN and WSN with a preliminarily in-service date in Oct. 2030. It is included in power flow cases for this study.
- 5) There is a planned capital project called GTTT will construct two 500 kV lines 5L65 and 5L66 from Glenannan to Skeena substation. The scheduled ISD of GTTT is Oct. 2031, therefore it is included in power flow cases for this study.
- 6) There is a planned capital project: 5L61/62/63 thermal upgrades. The scheduled ISD of this project is Oct. 2031, therefore it is included in power flow cases for this study.

- 7) [REDACTED] project has a POI at GLN 230kV bus. The [REDACTED]
[REDACTED] project is included in power flow cases for this study.

5 System Studies and Results

5.1 Power Flow Study Results

Power flow studies were performed to evaluate whether the IC's generating project would cause any unacceptable system performance (e.g. equipment overloads, steady-state voltage violation and voltage instability) and to determine the system reinforcement requirement based on steady state performance analysis.

The study focuses on the base scenario — 32HW/33LS/33HS system conditions. These base cases were prepared based on factors such as load conditions, seasonal variation in ambient temperatures, and generation patterns that stress the transmission system.

The studies are performed for system normal conditions and under critical system contingencies specified in the P1 and P2 events by NERC TPL-001-4. Study results are summarized below.

5.1.1 Thermal Overload Analysis

For all the studied load conditions (32HW, 33LS, 33HS) there is no branch overload identified under system normal condition (P0) and single contingency conditions (P1 and P2). Appendix B shows the details in the branch loading study results.

5.1.2 Steady-State Voltage Analysis

With the connection of the IC's project, the steady-state voltage performance under system normal and single contingency conditions is acceptable for all the three load conditions (33LS, 33HS, 32HW). Appendix B shows the details in the steady-state voltage study results.

5.1.3 Reactive Power Capability Evaluation

The BC Hydro TIR requires IBR power plant to have the dynamic reactive power capability at a minimum of +/- 33% of its MPO at the high voltage side of the IC's switchyard over the full MW operating range.

Based on the IC-submitted PSS/E model, the proposed [REDACTED] project does not meet the [REDACTED]

requirement above, which needs to be addressed if the project proceeds to the next stage of the interconnection process.

In addition, according to the IC-provided reactive capability data, the proposed WTG would provide +1.7 Mvar to -1.9 Mvar reactive capability at the zero MW output if the turbine's "STATCOM" function is enabled. This function needs to be re-confirmed if the IC's project proceeds to next stage of the interconnection process.

5.1.4 Anti-Islanding Requirements

[REDACTED] is not arranged for islanded operation. In addition, the IC is required to install anti-islanding protection within its facility to disconnect the IC's wind farm from the grid when an inadvertent island with the local loads forms.

5.1.5 Other Performance Requirements

Fast Frequency Response, also known as Virtual Inertia Control (VIC) in the proposed wind turbines, is required at the [REDACTED]. The proposed wind turbine generators, when equipped with the VIC option, are expected to temporarily boost the MW output to limit the system frequency drop during a major frequency event. The VIC settings should be determined in coordination with BC Hydro in the later stage of the interconnection process.

5.2 Fault Analysis

The short circuit analysis in the FeS is based upon the latest BC Hydro system model, which includes the generating facility information and associated impedance data provided by the IC. A more detailed study will be performed at the System Impact Study stage if needed.

5.3 Stations Requirements

The Point of Interconnection (POI) is 230 kV switchyard of the existing GLN Substation.

Following station work is required at Gelnannan Substation:

- Extend 230 kV existing 2M2 main bus to facilitate 230 kV line position.
- Add two new 230 kV circuit breakers and the associated disconnect switches to create line position for the [REDACTED] customer.
- Add one line terminal 2LXXX for [REDACTED] customer including the associate motor operated disconnect switch, surge arrester, and capacitor voltage transformer.
- Expand the control building, if required, to accommodate new P&C panels and other equipment.
- Other associated station work.
- All the above-mentioned additions and modifications will be implemented within the existing property boundaries.

Refer to the one-line diagram in Appendix C for details.

6 Cost Estimate and Schedule

The non-binding good faith estimated cost and time to construct the Network Upgrades required to interconnect the proposed project will be provided in a separate letter to the IC.

7 Conclusions

To interconnect the [REDACTED] and its facilities to the BCH Transmission System at the POI, this Feasibility Study has identified the following conclusions and requirements:

1. A new 230 kV line position is required at GLN substation to facilitate the interconnection of [REDACTED]. The 230 kV line position shall have an independent switching and protection zone.
2. The connection of [REDACTED] does not cause any performance violation (i.e. thermal overload, voltage performance violation or voltage stability concern) under system normal and single contingency conditions.
3. The impact on BC Hydro bulk transmission system is not part of the project scope of the feasibility study. However, it should be noted that [REDACTED] is required to participate in the existing BC Hydro generation shedding RAS to address various performance issues for contingencies in BC Hydro's 500 kV transmission system.
4. [REDACTED] is required to install anti-islanding protection within its facility to disconnect the IC's generating plant from the grid when an inadvertent island with the local load forms. The anti-islanding protection shall be configured in the manner that does not compromise the required ride-through performance.
5. The [REDACTED] is required to have the dynamic reactive power capability at a minimum of +/- 33% of its MPO at the high voltage side of the IC's switchyard over the full MW operating range, per BC Hydro's TIR Section 6.4.2.
6. The "STATCOM option" for the proposed type-3 WTGs is required so that each turbine can provide reactive power capability at zero MW output. BC Hydro recognizes that Type-3 WTGs with the STATCOM option have an

inherent limitation—providing only partial reactive power capability during turbine standstill.

7. Fast Frequency Response, also known as Virtual Inertia Control (VIC) in the proposed wind turbines, is required at the [REDACTED]. [REDACTED]. The proposed wind turbine generators, when equipped with the VIC option, are expected to temporarily boost the MW output to limit the system frequency drop during a major frequency event. The VIC settings should be determined in coordination with BC Hydro in the later stage of the interconnection process.

Appendix A

Schematic Diagram of the IC's Project

Figure A-1 shows the schematic diagram for the [REDACTED] as submitted.

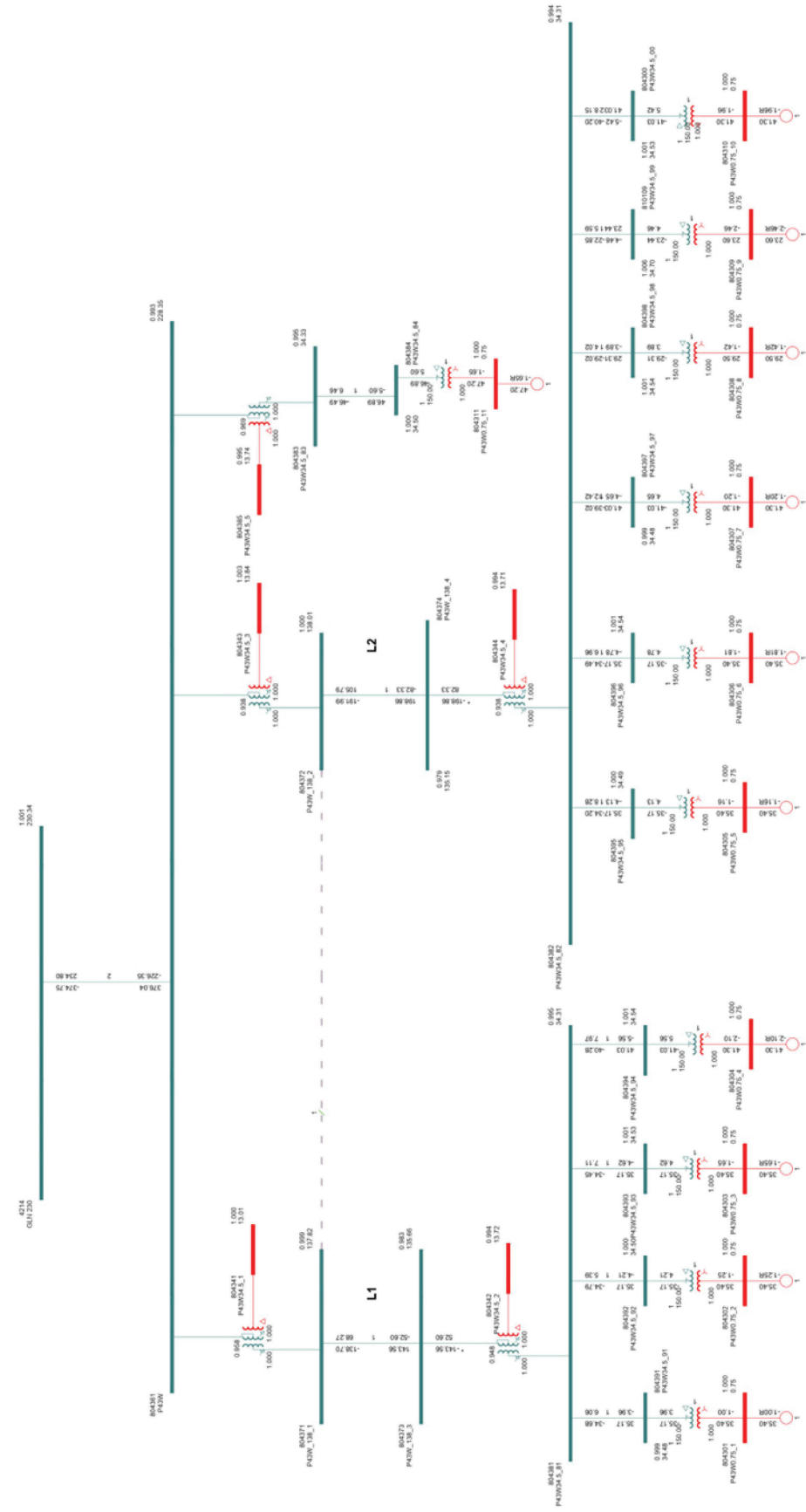

Figure A-1: Plant Schematic Diagram.

Appendix B

Power Flow Study Results

Table B-1: Thermal Overload Study Results

Case	IC's Plant Output	Contingency		Branch Loading	
		Category	Description	GLN T1 500/230KV	2L353 GLN-TAC
Winter Rating (MVA)				714	119.5
32HW	MAX	P0	System Normal	36%	22%
	MAX	P1.3	GLN T2&T5 (Note 1)	73%	20%
	MAX	P2.3	GLN 1CB2 (Note 2)	77%	20%
Summer Rating (MVA)				600	119.5
33HS	MAX	P0	System Normal	46%	25%
	MAX	P1.3	GLN T2&T5	92%	25%
	MAX	P2.3	GLN 1CB2	95%	25%
33LS	MAX	P0	System Normal	46%	30%
	MAX	P1.3	GLN T2&T5	93%	29%
	MAX	P2.3	GLN 1CB2	96%	30%

Note 1: GLN T2 and GLN T5 are in the same protection zone.

Note 2: GLN 1CB2 internal fault results in loss of GLN T2, T5 and 1L384.

Table B-2: Steady-State Voltage Study Results

Case	IC's Plant Output	Contingency		Bus Voltage (PU)		
		Category	Description	GLN 500 KV	GLN 230 KV	TAC 230 KV
32HW	MAX	P0	System Normal	1.061	1.026	1.014
	MAX	P1.3	GLN T2&T5	1.059	1.013	1.002
	MAX	P2.3	GLN 1CB2	1.059	1.013	1.002
33HS	MAX	P0	System Normal	1.048	1.015	1.004
	MAX	P1.3	GLN T2&T5	1.046	1.000	0.989
	MAX	P2.3	GLN 1CB2	1.046	0.999	0.988
33LS	MAX	P0	System Normal	1.060	1.026	1.014
	MAX	P1.3	GLN T2&T5	1.058	1.013	1.002
	MAX	P2.3	GLN 1CB2	1.057	1.010	0.998

Appendix C

One-Line Sketch for GLN Substation

Figure C-1 shows the Stations Planning One-Line Sketch for GLN Substation updates to interconnect IC's [REDACTED].

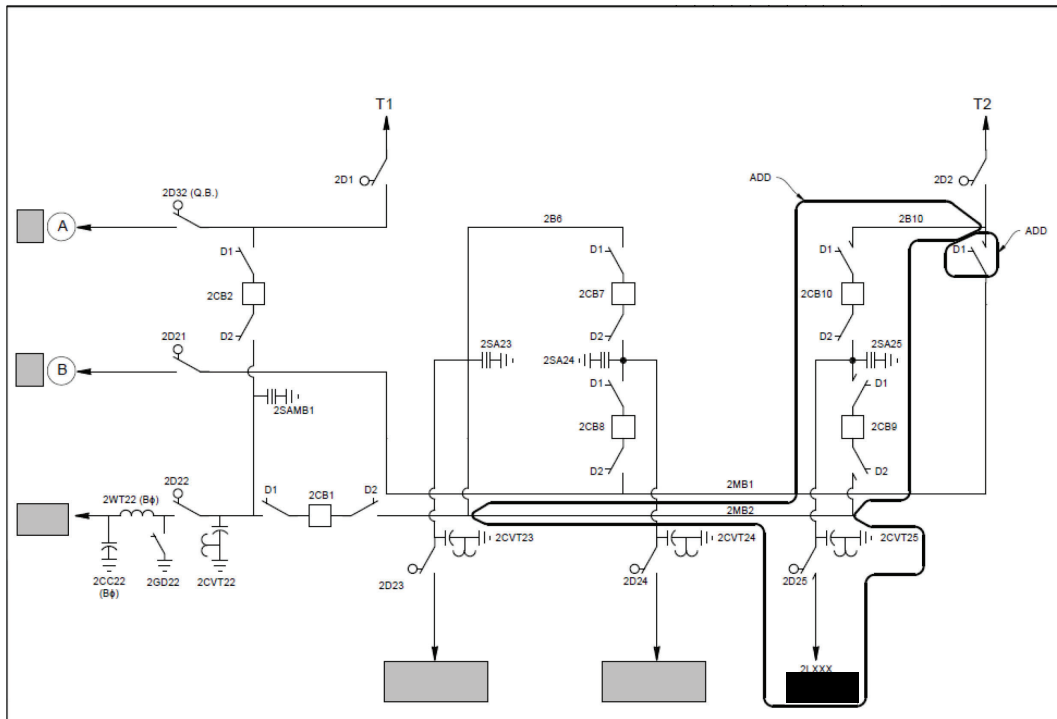

Figure C-1: Stations Planning One-Line Sketch for GLN.