

6911 Southpoint Drive (B03)
Burnaby, BC
V3N 4X8

November 24, 2025

[REDACTED]
[REDACTED]
[REDACTED]
via email: [REDACTED]

RE: CEAP IR #120 – [REDACTED] – Interconnection Feasibility Study

Dear [REDACTED]

Enclosed is the Interconnection Feasibility Study for the proposed Interconnection Request (IR), [REDACTED] submitted under Attachment M-2: Transmission Service and Interconnection Service Procedures for Competitive Electricity Acquisition Process (CEAP) of the Open Access Transmission Tariff (OATT). This letter provides a non-binding good faith estimate of the cost and time to construct the facilities required to interconnect your project to BC Hydro's Transmission System, being the Network Upgrades, based on the findings of the Interconnection Feasibility Study.

Open Access Transmission Tariff

The OATT defines Network Upgrades as additions, modifications, and upgrades to BC Hydro's Transmission System required at or beyond the Point of Interconnection to accommodate the interconnection of the Generating Facility to the BC Hydro's Transmission System. Pursuant to the OATT, BC Hydro will design, procure, construct, install, and own the Network Upgrades. While BC Hydro will pay the costs for the Network Upgrades, the Interconnection Customer provides security for such costs.

Interconnection Study Costs

The Interconnection Customer is responsible for paying the full cost of all Interconnection Studies in cash. Interconnection Study costs vary depending on the scope, complexity, and other factors such as whether any scope is shared with another Interconnection Customer (not applicable to this Interconnection Feasibility Study). The deposit amounts specified in the OATT are not proxy Interconnection Study costs. If actual Interconnection Study costs exceed the deposit amount, the Interconnection Customer must pay the remaining balance in cash. Please refer to the answer for question no. 53 in the posted [Questions & Answers for 2025 Call for Power](#) for typical study cost ranges.

Cost Estimate

Based on the Interconnection Feasibility Study, the non-binding good faith estimated cost (typical accuracy range of +150%/-50%) for Network Upgrades required to interconnect your project is \$230.2 M.

Major Scope of Work Identified:

- Acquire property and construct a new 138 kV, 3-circuit breaker ring bus switching substation on 1L274
- Construct a new control building and other required substation facilities and infrastructures
- Cut the existing 1L274 and loop into the substation

- Terminate 138 kV line of [REDACTED] at the substation
- Supply and install required Protection, Control and Telecommunications equipment

Exclusions:

- GST
- Permits
- Right-of-Way & property costs
- Worker camp costs

Key Assumptions:

- Construction by contractor
- 30 months of construction is considered
- No construction during winter season
- Execution of early Engineering and Procurement Agreement
- Ability to acquire adequate property for a new switching station close to the existing transmission line 1L274 No expansion of existing stations or control buildings to accommodate new equipment
- Impact Benefit Agreements with First Nations are not considered

Key Risks:

- Cost and ability of obtaining new property for the new switching station may be higher than estimated which may increase the Network Upgrade cost estimate and schedule.
- Expansion of the existing control building may be required leading to increased costs and/or a longer project schedule
- Major equipment delivery presents potential project cost and schedule risks, based on variance in equipment lead times
- No defined supply chain strategy; construction costs may increase depending on delivery method
- Project schedule may be longer than expected, leading to increased overhead costs
- Ground improvements may be required leading to increased construction costs
- Contaminated soil may be encountered leading to increased construction costs
- Cost of materials and major equipment may be affected by market conditions and escalation

Study Limitations and Exclusions***Protection, Control, and Telecommunications***

The Interconnection Feasibility Study does not include a detailed review of the protection, control, and telecommunications system requirements specific to your Interconnection Request. Based on a high-level review, we have identified proxy costs for protection, control, and telecom Network Upgrades drawn from comparable interconnection projects with similar scope and complexity; these proxy costs have been included solely for indicative budgeting purposes. The relative interconnection cost determined by the Interconnection Feasibility Study includes a telecommunications component based on an assumed solution to deliver teleprotection and telecontrol circuit requirements necessary for the Interconnection Request. Protection, control, and telecommunications system requirements will be reviewed in detail in the System Impact Study if you are a successful participant of the CEAP and meet applicable requirements.

For Interconnection Feasibility Study purposes, it is assumed that any applicant-proposed works that could obstruct or impair the performance of existing BC Hydro microwave systems or new links from the proposed Interconnection Customer Interconnection Facilities (ICIF) to the BC Hydro microwave system would be identified and either relocated or repositioned as determined in a System Impact Study if you are a successful participant of the CEAP and meet applicable requirements. Such works may include, but are not limited to, towers, turbines, dams, support structures, panels, surface materials deposited or redistributed, water surface changes, or vegetation.

Generation Shedding/Curtailment Scheme and Electromagnetic Transient (EMT) Studies

The generation shedding/curtailment scheme reviews (e.g., Remedial Action Scheme (RAS), and a direct transfer trip for anti-islanding scheme) and EMT studies are completed in a System Impact Study. The outcomes of these studies may result in additional requirements, which could include Network Upgrades or ICIF. Any costs associated with completion of these studies, and resulting requirements, are not included in the Interconnection Feasibility Study cost estimate.

Revenue Metering

Please note that revenue metering requirements have not been determined with the Interconnection Feasibility Study. As such, any costs associated with revenue metering and other interconnection components are not included in the cost estimate provided above. Once these requirements are defined, costs that are attributable to the Interconnection Customer are to be paid in cash. For more details on revenue metering requirements and responsibilities, please refer to:

<https://www.bchydro.com/content/dam/BCHydro/customer-portal/documents/distribution/standards/ds-rmr-complex-revenue-metering.pdf>.

Schedule

Based on the Interconnection Feasibility Study, the non-binding good faith estimated in-service date for your Interconnection Request's Network Upgrades is Quarter 3 2033 (calendar year). To achieve this timeline, we may need to expedite certain activities, including engineering design and procurement of long-lead equipment.

Timely actions required from you to minimize risks to the schedule:

- Submission of additional technical data required for the System Impact Study and Facilities Study
- Submission of any required information or document such as demonstration of Site Control
- Execution of Combined Study Agreement and Standard Generator Interconnection Agreement
- Financial commitments and securities

Please note that changes to your Interconnection Request or delays in data submission or financial commitments may also impact the target in-service date.

If you have any questions, please contact the BC Hydro CEAP team at ceap2025@bchydro.com.

Sincerely,

[Redacted signature]

[Redacted name]

Manager, Customer Interconnections

BC Hydro

Encl.: CEAP_2025_IR120_[Redacted]_Feasibility_Study.pdf

Interconnection Feasibility Study

BC Hydro EGBC Permit to Practice No: 1002449

2025 CEAP IR # 120

Prepared for:



Prepared by:

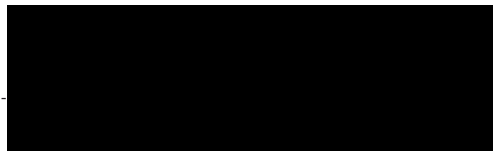

Engineer, Transmission Planning

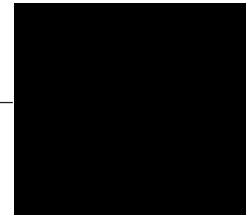

Reviewed by:

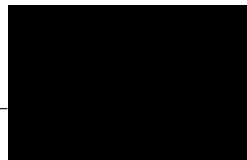

Principle Engineer, Transmission
Planning

Accepted by:



Manager, Transmission Planning

Report Metadata

Header: 2025 CEAP IR # 120
Subheader: Interconnection Feasibility Study
Title: [REDACTED]
Subtitle: 2025 CEAP IR # 120
Report Number: 100-APR-00011
Revision: 0
Confidentiality: Public
Date: 2025 Nov 21
Volume: 1 of 1

Prepared for: [REDACTED]
Prepared by: [REDACTED]
Title: Engineer, Transmission Planning
Checked by: [REDACTED]
Title: Consultant, Transmission Planning
Reviewed by: [REDACTED]
Title: Principle Engineer, Transmission Planning

Related Facilities: 1L274 (138 kV)
Additional Metadata: Transmission Planning 2025-127
Filing Subcode 1350

Revisions

Revision	Date	Description
0	2025 Nov	Initial release

Disclaimer of Warranty, Limitation of Liability

This report was prepared solely for internal purposes. All parties other than BC Hydro are third parties.

BC Hydro does not represent, guarantee or warrant to any third party, either expressly or by implication:

any information, product or process disclosed, described or recommended in this report.

BC Hydro does not accept any liability of any kind arising in any way out of the use by a third party of any information, product or process disclosed, described or recommended in this report, nor does BC Hydro accept any liability arising out of reliance by a third party upon any information, statements or recommendations contained in this report. Should third parties use or rely on any information, product or process disclosed, described or recommended in this report, they do so entirely at their own risk.

This report was prepared by the British Columbia Hydro And Power Authority ("BCH") or, as the case may be, on behalf of BCH by persons or entities including, without limitation, persons or entities who are or were employees, agents, consultants, contractors, subcontractors, professional advisers or representatives of, or to, BCH (individually and collectively, "BCH Personnel").

This report is to be read in the context of the methodology, procedures and techniques used, BCH's or BCH's Personnel's assumptions, and the circumstances and constraints under which BCH's mandate to prepare this report was performed. This report is written solely for the purpose expressly stated in this report, and for the sole and exclusive benefit of the person or entity who directly engaged BCH to prepare this report. Accordingly, this report is suitable only for such purpose, and is subject to any changes arising after the date of this report. This report is meant to be read as a whole, and accordingly no section or part of it should be read or relied upon out of context.

Unless otherwise expressly agreed by BCH:

- (a) any assumption, data or information (whether embodied in tangible or electronic form) supplied by, or gathered from, any source (including, without limitation, any consultant, contractor or subcontractor, testing laboratory and equipment suppliers, etc.) upon which BCH's opinion or conclusion as set out in this report is based (individually and collectively, "Information") has not been verified by BCH or BCH's Personnel; BCH makes no representation as to its accuracy or completeness and disclaims all liability with respect to the Information;
- (b) except as expressly set out in this report, all terms, conditions, warranties, representations and statements (whether express, implied, written, oral, collateral, statutory or otherwise) are excluded to the maximum extent permitted by law and, to the extent they cannot be excluded, BCH disclaims all liability in relation to them to the maximum extent permitted by law;
- (c) BCH does not represent or warrant the accuracy, completeness, merchantability, fitness for purpose or usefulness of this report, or any information contained in this report, for use or consideration by any person or entity. In addition, BCH does not accept any liability arising out of reliance by a person or entity on this report, or any information contained in this report, or for any errors or omissions in this report. Any use, reliance or publication by any person or entity of this report or any part of it is at their own risk; and
- (d) In no event will BCH or BCH's Personnel be liable to any recipient of this report for any damage, loss, cost, expense, injury or other liability that arises out of or in connection with this report including, without limitation, any indirect, special, incidental, punitive or consequential loss, liability or damage of any kind.

Copyright Notice

Copyright and all other intellectual property rights in, and to, this report are the property of, and are expressly reserved to, BCH. Without the prior written approval of BCH, no part of this report may be reproduced, used or distributed in any manner or form whatsoever.

Contributors

The following accept responsibility for the content in the specified sections. Professionals apply their signature and/or seal as appropriate.

Section:
the entire report
except those
listed below

Discipline:
Transmission Planning

Contributed by:



Principle Engineer, Transmission
Planning

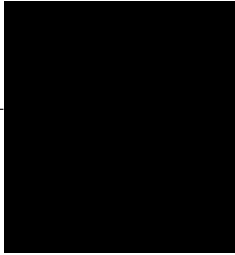

Section:
5.2, 5.3

Discipline:
Stations Planning

Contributed by:





Specialist Engineer, Station Planning



Section:
5.4

Discipline:
Transmission Lines Engineering

Contributed by:



Sr. Engineer, Transmission Lines
Engineering

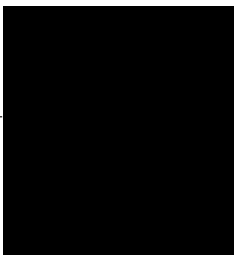

Executive Summary

████████████████████ the Interconnection Customer (IC), requests to interconnect its ██████████ (2025 CEAP IR # 120) to the BC Hydro (BCH) system. The ██████████ project has 12 – ██████████ solar inverters with a maximum power injection of 50.4 MW into the BC Hydro system at the Point of Interconnection (POI). The IPP's proposed Point of Interconnection (POI) is 1.05 km north of Elkfords Tap station (EFT) at or close to the Green Hills substation (GRH) tap point in 1L274 Natal (NTL)-Pocaterra (POC) (Alberta (AB) TAU transmission system generating station). The project will have a maximum supply capacity of 50.04 MW to the BCH system and its proposed Commercial Operation Date (COD) is 1 September, 2033.

Transmission planning assessed the impact of interconnecting the proposed generating project to the BC Hydro system and identified the system modifications required to obtain acceptable system performance.

Transmission Planning's studies have made the following conclusions:

- 1) A new 138 kV switching station (referred to as "P120T") on 1L274 is required at the proposed POI for interconnecting the IC's generating project to the BCH system. With the new switching station P120T, the existing line 1L274 will be segregated into two new circuits, temporarily referred to as: 1L274_A (EFT-P120T) and 1L274_B (P120T-██████████ switching station(BCK)). The interconnection line, to be built by the IC, is temporarily referred to as 1L274_C (P120-P120T). These temporary line designations will be replaced by permanent ones at a later stage of interconnection study.
- 2) The connection of ██████████ does not cause any performance violations (i.e. thermal overload or voltage performance violation) under system normal conditions and various system single contingencies.
- 3) An Anti-islanding transfer trip scheme is required to isolate the solar farm to avoid potential islanding operations with BC Hydro loads.
- 4) The proposed ██████████ project is required to have the dynamic reactive power capability at a minimum of +/- 33% of its MPO from the plants at the high-voltage side of the switchyard over the full MW operating range, per BC Hydro's TIR Section 6.4.2. Based on the IC-submitted PSS/E model,

the proposed [REDACTED] project does not meet the reactive capability requirement. This deficiency will need to be addressed if the IR is to move forward in the CEAP evaluation process.

- 5) The “Reactive Power at Night” function for the SMA solar inverter is required so that each inverter can provide reactive power capability at zero MW output including during nighttime.

The above conclusions are made based on assumptions available at the time of performing this Feasibility Study. Those assumptions represent the information received on or before Oct 14th, 2025.

A non-binding good-faith cost estimate and construction schedule for the Network Upgrades required to interconnect the proposed project will be provided in a separate letter to the IC.

Please note that, this Feasibility Study report does not include the descriptions of Protection, Control, and Telecommunications requirements and the associated upgrade scopes; however, as discussed in Section 2 “Purpose and Scopes of Study, the associated cost implications are captured and delivered in the cover letter to the IC”.

Contents

Executive Summary	vi
1 Introduction	1
2 Purpose and Scopes of Study	3
3 Standard and Criteria	4
4 Assumptions and Conditions	5
5 System Studies and Results	6
5.1 Power Flow Study Results	6
5.1.1 Branch Loading Analysis	6
5.1.2 Steady-State Voltage Analysis	7
5.1.3 Reactive Power Capability Evaluation	7
5.1.4 Anti-Islanding Requirements	7
5.2 Fault Analysis	7
5.3 Stations Requirements	7
5.4 Transmission Line Requirements	8
6 Cost Estimate and Schedule	9
7 Conclusions	10

Appendices

APPENDIX A	PLANT SINGLE LINE DIAGRAM USED FOR POWER FLOW STUDY
APPENDIX B	POWER FLOW STUDY RESULTS
APPENDIX C	NEW [REDACTED] PROJECT SWITCHING STATION (P120T) ONE-LINE DIAGRAM

Acronyms

The following are acronyms used in this report.

BCH	BC Hydro
CEAP	Competitive Electricity Acquisition Process
COD	Commercial Operation Date
DTT	Direct Transfer Trip
EDM	Edmonds Office
ERIS	Energy Resource Interconnection Service
FeS	Feasibility Study
FVO	Fraser Valley Office
IBR	Inverter-Based Resources
IC	Interconnection Customer
IR	Interconnection Request
MPO	Maximum Power Output
NERC	North American Electric Reliability Corporation
NRIS	Network Resource Interconnection Service
OATT	Open Access Transmission Tariff
POI	Point of Interconnection
RAS	Remedial Action Scheme
SIC	South Interior Control
SIO	South Interior Office
TIR	BC Hydro “60 kV to 500 kV Technical Interconnection Requirements for Power Generators”
WECC	Western Electricity Coordinating Council

BCH SIE transmission system in the NTL area with the [REDACTED] project added.

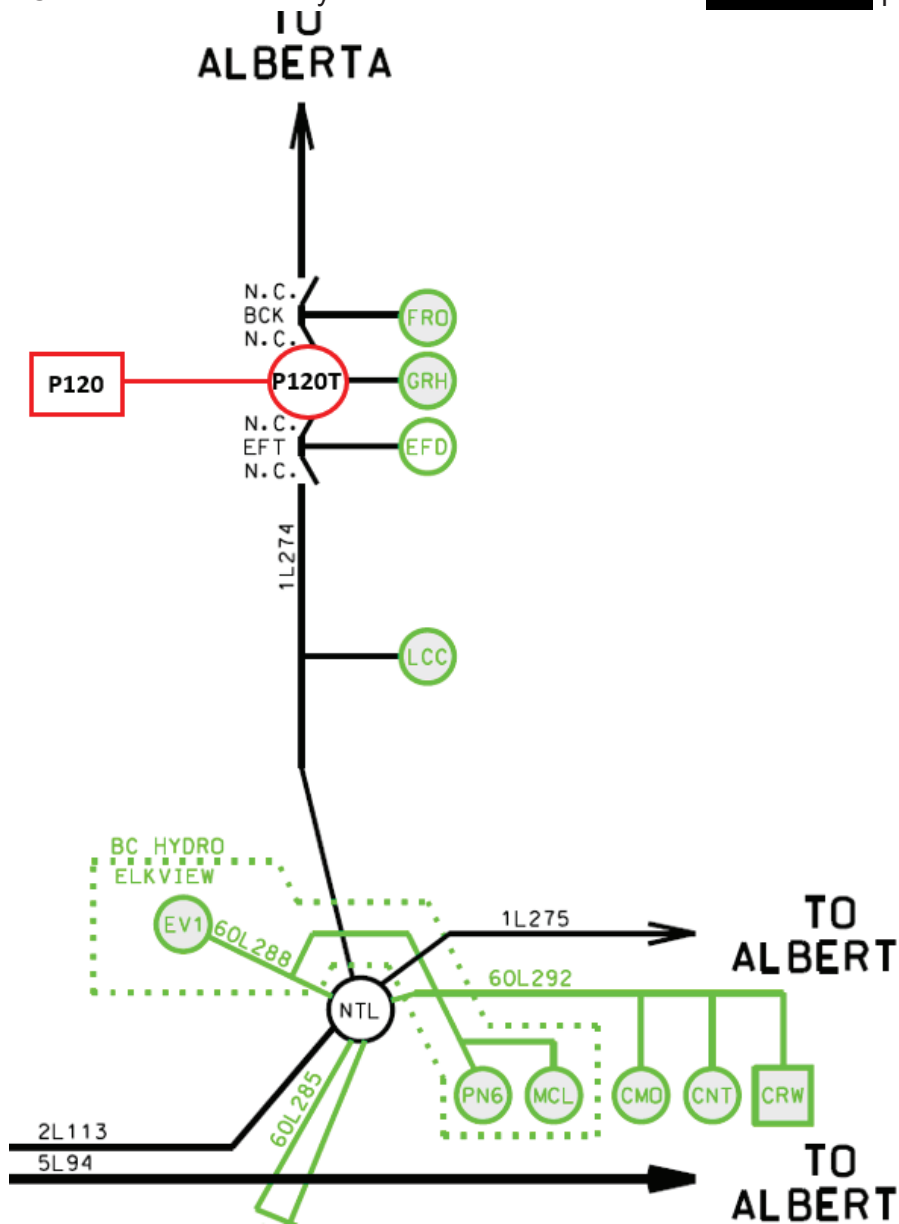

Figure 1-1: BCH SIE transmission system in the NTL area with the [REDACTED] project added

2 Purpose and Scopes of Study

This Feasibility Study is a preliminary evaluation of the system impact of interconnecting the proposed project to the BC Hydro system based on power flow and short circuit analysis in accordance with BCH's Open Access Transmission Tariff (OATT) and produces the estimated cost of required Network Upgrades and the implementation schedule.

Per OATT, the Feasibility Study is performed individually for each of the participating projects in the CEAP process and focuses specifically on the BC Hydro regional transmission system where the proposed generating project is connected and affects.

This is a "limited scope" study which is restricted to power flow studies of P0, P1 and P2 planning events as defined in TPL-001-4 and short circuit analysis. The study does not address other technical aspects such as transient stability and switching transients and impact of multiple contingencies. These subjects will be addressed in subsequent System Impact Study if the project proceeds further. In addition, any potential impacts to the adjacent external systems to BC Hydro would be addressed in subsequent detailed and coordinated studies with the relevant adjacent entities if the proposed generator project proceeds further.

Please note that, due to the compressed study timeline for 2025 CEAP Feasibility Study, this report does not include the descriptions of the Protection, Control, and Telecommunication requirements and the associated upgrade scopes. Instead, the network upgrades associated with Protections, Controls and Telecommunications are incorporated with cost estimates in a separate cover letter to the IC.

3 Standard and Criteria

The Feasibility Study is performed in compliance with the North American Electric Reliability Corporation (NERC) and Western Electricity Coordinating Council (WECC) reliability standards, and the BCH interconnection requirements in the TIR, and upon the ratings of the existing BCH transmission facilities described in Operating Orders, specifically:

- NERC standards: TPL-001-4 and FAC-002-3 relevant to the scope of this Feasibility Study.
- WECC criteria TPL-001-WECC-CRT-4 Transmission System Planning Performance, July 1, 2023.
- BC Hydro's 60 kV to 500 kV Technical Interconnection Requirements for Power Generators, Rev 2.1.1, Effective: Sept 22, 2025.
- BC Hydro Operating Order 5T-10, Ratings for All Transmission Circuits 60 kV or Higher, September 17, 2025.
- BC Hydro Operating Order 5T-14, Ratings for All Transmission and Distribution Transformer, Sept 22, 2025.
- BC Hydro System Operating Order 7T-22 System Voltage Control, September 19, 2023.

4 Assumptions and Conditions

This Feasibility Study is performed based on the IC's submitted data and information available to BC Hydro on October 14th, 2025 for the study purpose. Appendix A shows the plant single line diagram for the IC's project used in the study model. Certain assumptions were, as set out below, made to the extent required.

The power flow study cases used in this Feasibility Study are established based upon the BC Hydro's base resource plan and load forecasts available at the time of performing the study, which includes existing and future generations, transmission facilities, and loads in addition to the subject interconnection project in this study. Applicable seasonal conditions and the appropriate study years for the study planning horizon are also incorporated.

Additional assumption is listed as follows:

- 1) The regional generation are dispatched to the patterns that stress the transmission system in the study area. In these patterns, the regional generations are typically set to their Maximum Power Outputs (MPO) unless otherwise specified.

5 System Studies and Results

Based upon the IC's submitted information and the area system conditions, a new switching station (referred to as "P120T") at the proposed POI on 1L274 is required to interconnect the IC's generating project to the BCH system. There are multiple terminals and multiple sources on the existing line 1L274. The addition of the new switching station is required to maintain reliability and adequate protection performance to accommodate the new interconnection and serve the existing customers.

With the new switching station P120T, the existing line 1L274 will be segregated into two new circuits, temporarily referred to as: 1L274_A (EFT-P120T) and 1L274_B (P120T-BCK). The interconnection line, to be built by the IC, is temporarily referred to as 1L274_C (P120-P120T). These temporary line designations will be replaced by permanent ones at a later stage of interconnection study.

5.1 Power Flow Study Results

Power flow studies were performed to evaluate whether the IC's generating project would cause any unacceptable system performance (e.g. equipment overloads, steady-state voltage violation and voltage instability) and to determine the system reinforcement requirement based on steady state performance analysis.

The study focuses on the base scenario — 33HW/33LS/33HS system conditions. These base cases were prepared based on factors such as load conditions, seasonal variation in ambient temperatures, and generation patterns that stress the transmission system.

5.1.1 Branch Loading Analysis

Table B-1 in Appendix B shows a summary of branch loading analysis under system normal and single contingencies (P1) for various load conditions.

The study finds no transformer or line overload under system normal and single contingencies (Category P1) for all three load conditions studied.

5.1.2 Steady-State Voltage Analysis

For the studied load conditions 33HW, 33LS, and 33LS, the voltage performance under system normal condition and single contingency (P1) is acceptable. Table B-2 in Appendix B shows a summary of steady-state voltage performance under various system conditions and contingencies.

5.1.3 Reactive Power Capability Evaluation

The BC Hydro TIR requires IBR power plant to have the dynamic reactive power capability at a minimum of +/- 33% of its MPO at the high voltage side of the IC's switchyard over the full MW operating range.

Based on the PSS/E power flow data submitted by the IC, the proposed generating project does not meet the BC Hydro's reactive capability requirement at the plant's maximum MW output, which is subjected to further verification in the next stage of interconnection study of the Var deficiency.

Furthermore, the BCH TIR requires the IC's project to provide sufficient reactive power capability over full MW operating range including at zero MW output level.

The deficiency of reactive capabilities of the IPP's plant to meet BCH requirements is subject to confirmation in the next stage of studies if this project is selected to move forward in the 2025 CEAP selection process.

5.1.4 Anti-Islanding Requirements

An Anti-islanding transfer trip scheme is required to isolate the solar farm to avoid potential islanding operations with BC Hydro loads.

5.2 Fault Analysis

The short circuit analysis in the FeS is based upon the latest BC Hydro system model, which includes the generating facility information and associated impedance data provided by the IC. A more detailed study will be performed at the System Impact Study stage if needed.

5.3 Stations Requirements

Scope of work at the new switching substation (P120T):

A new outdoor 138kV, 3-circuit breaker ring bus switching substation (Referred to P120T temporarily) will be built at POI, close to the existing 138kV transmission line 1L274. The existing transmission line 1L274 will be cut and looped into the new substation. 138kV line of [REDACTED] will be terminated at the new substation.

- 1) Acquire adequate property for a new substation close to the existing transmission line 1L274.
- 2) Construct a new outdoor 138 kV, 3-circuit breaker ring bus switching substation. Refer to the one-line diagram Appendix C for details.
- 3) Construct a new control building and other required substation facilities and infrastructures.
- 4) Cut the existing 1L274 and loop into the substation.
- 5) Terminate 138 kV line of [REDACTED] at the substation.
- 6) The location of metering kits will be determined in next stage.

5.4 Transmission Line Requirements

No transmission line engineering scope of work is identified for this project at this stage.

6 Cost Estimate and Schedule

The non-binding good faith estimated cost and time to construct the Network Upgrades required to interconnect the proposed project will be provided in a separate letter to the IC.

7 Conclusions

To interconnect the [REDACTED] project and its facilities to the BCH Transmission System at the POI, this Feasibility Study has identified the following conclusions and requirements:

- 1) A new 138 kV switching station (referred to as “P120T”) on 1L274 is required at the proposed POI for interconnecting the IC’s generating project to the BCH system. With the new switching station P120T, the existing line 1L274 will be segregated into two new circuits, temporarily referred to as: 1L274_A (EFT-P120T) and 1L274_B (P120T-BCK). The interconnection line, to be built by the IC, is temporarily referred to as 1L274_C (P120-P120T). These temporary line designations will be replaced by permanent ones at a later stage of interconnection study.
- 2) The connection of [REDACTED] does not cause any performance violations (i.e. thermal overload or voltage performance violation) under system normal conditions and various system single contingencies.
- 3) An Anti-islanding transfer trip scheme is required to isolate the solar farm to avoid potential islanding operations with BC Hydro loads.
- 4) The proposed [REDACTED] project is required to have the dynamic reactive power capability at a minimum of +/- 33% of its MPO from the plants at the high-voltage side of the switchyard over the full MW operating range, per BC Hydro’s TIR Section 6.4.2. Based on the IC-submitted PSS/E model, the proposed [REDACTED] project does not meet the reactive capability requirement. This deficiency of Var capability will need to be addressed if the IR is to move forward in the CEAP evaluation process.
- 5) The “Reactive Power at Night” function for the SMA solar inverter is required so that each inverter can provide reactive power capability at zero MW output including during nighttime.

Appendix A

Plant Single Line Diagram Used for Power Flow Study

Figure A-1 shows [REDACTED] project single line diagram used for power flow study.

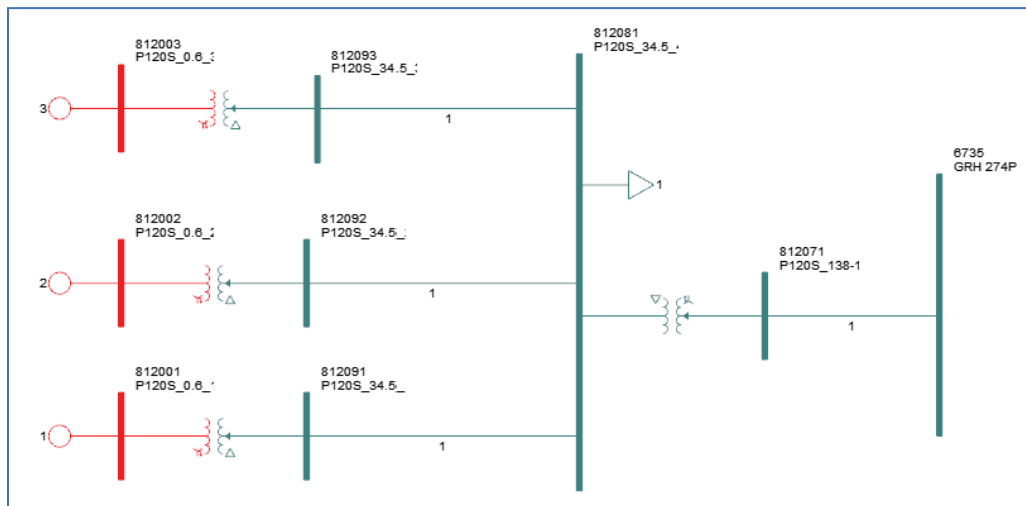

Figure A-1: [REDACTED] Single Line Diagram for Power Flow Study.

As per the diagram above, the [REDACTED] project has 3 – 34.5 kV collector feeders, one main 34.5/138 kV transformer, and a 10 m 138 kV transmission line connecting the substation to the new [REDACTED] project switching station.

Appendix B

Power Flow Study Results

Table B-1 Summary of Key Branch Loading Analysis Results

Case	IPP's Generator Output	Contingency Identified		Branch Loading	
				1L274	1L274
		Cate-gory	Description	GRH-EFT	GRH-BCK
33HS	50.16 MW	P0	System Normal	14.5 MVA/22%	43.2 MVA /66%
		P1	1L274 POI to AB	32.7 MVA/50%	N/A
		P1	NTL 60/138 KV T8	13.8 MVA /21%	43.4 MVA /67%
		P1	NTL 230/60 KV T4	13.4 MVA /21%	43.2 MVA /66%
33LS	50.16 MW	P0	System Normal	14 MVA /21%	44.5 MVA /68%
		P1	1L274 POI to AB	35.3 MVA /53%	N/A
		P1	NTL 60/138 KV T8	14 MVA /21%	44.5 MVA /68%
		P1	NTL 230/60 KV T4	14 MVA /21%	44.5 MVA /68%
33HW	50.16 MW	P0	System Normal	13.1 MVA /11%	41.5 MVA /36%
		P1	1L274 POI to AB	31.4 MVA /27%	N/A
		P1	NTL 60/138 KV T8	11.7 MVA /10%	40.4 MVA /35%
		P1	NTL 230/60 KV T4	11.7 MVA /10%	40.4 MVA /35%

Table B-2 Summary of Steady-State Voltage Study Results

Case	IPP's Generator Output	Contingency		Bus Voltage (PU)		
				POI	NTL 138	NTL 230
		Cate-gory	Description			
33HS	50.16 MW	P0	System Normal	0.99	1.01	1.04
		P1	1L274 POI to AB	1.00	1.01	1.04
		P1	NTL 60/138 KV T8	0.99	1.01	1.04
		P1	NTL 230/60 KV T4	0.99	1.01	1.04
33LS	50.16 MW	P0	System Normal	1.00	1.02	1.05
		P1	1L274 POI to AB	1.01	1.02	1.05

		P1	NTL 60/138 KV T8	1.00	1.02	1.05
		P1	NTL 230/60 KV T4	1.00	1.02	1.05
33HW	50.16 MW	P0	System Normal	0.99	1.00	1.03
		P1	1L274 POI to AB	0.99	1.00	1.03
		P1	NTL 60/138 KV T8	0.99	1.01	1.04
		P1	NTL 230/60 KV T4	0.99	1.01	1.04

Appendix C

New [REDACTED] Switching station (P120T) One-Line Diagram

Figure C-1 shows New [REDACTED] Switching station (P120T) One-Line Diagram

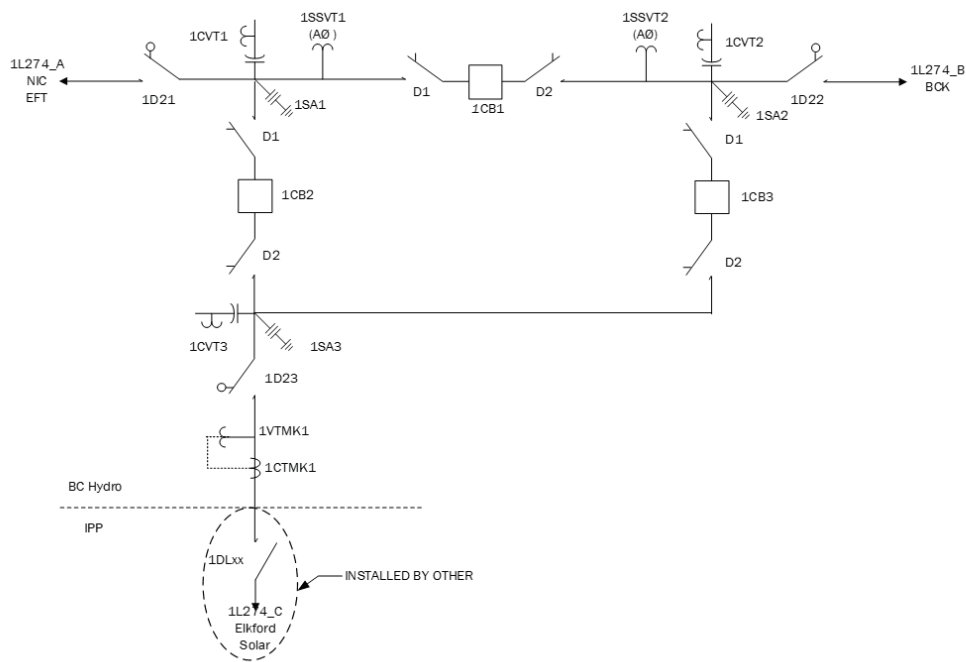

Figure C-1: New [REDACTED] Switching station (P120T) One-Line Diagram