

6911 Southpoint Drive (B03)  
Burnaby, BC  
V3N 4X8

November 24, 2025

[REDACTED]

via email: [REDACTED]

**RE: CEAP IR #104 – [REDACTED] – Interconnection Feasibility Study**

Dear [REDACTED]

Enclosed is the Interconnection Feasibility Study for the proposed Interconnection Request (IR), [REDACTED], submitted under Attachment M-2: Transmission Service and Interconnection Service Procedures for Competitive Electricity Acquisition Process (CEAP) of the Open Access Transmission Tariff (OATT). This letter provides a non-binding good faith estimate of the cost and time to construct the facilities required to interconnect your project to BC Hydro's Transmission System, being the Network Upgrades, based on the findings of the Interconnection Feasibility Study.

### **Open Access Transmission Tariff**

The OATT defines Network Upgrades as additions, modifications, and upgrades to BC Hydro's Transmission System required at or beyond the Point of Interconnection to accommodate the interconnection of the Generating Facility to the BC Hydro's Transmission System. Pursuant to the OATT, BC Hydro will design, procure, construct, install, and own the Network Upgrades. While BC Hydro will pay the costs for the Network Upgrades, the Interconnection Customer provides security for such costs.

### **Interconnection Study Costs**

The Interconnection Customer is responsible for paying the full cost of all Interconnection Studies in cash. Interconnection Study costs vary depending on the scope, complexity, and other factors such as whether any scope is shared with another Interconnection Customer (not applicable to this Interconnection Feasibility Study). The deposit amounts specified in the OATT are not proxy Interconnection Study costs. If actual Interconnection Study costs exceed the deposit amount, the Interconnection Customer must pay the remaining balance in cash. Please refer to the answer for question no. 53 in the posted [Questions & Answers for 2025 Call for Power](#) for typical study cost ranges.

### **Cost Estimate**

Based on the Interconnection Feasibility Study, the non-binding good faith estimated cost (typical accuracy range of +150%/-50%) for Network Upgrades required to interconnect your project is \$698.4 M.

### **Major Scope of Work Identified:**

- Build one new approximately 88 km 230 kV circuit from John Hart substation (JHS) to Dunsmuir substation (DMR)
- Install two 300 MVA 132/230 kV step-up transformers at JHS

- Expand JHS 132kV substation to accommodate two 132/230kV step-up transformers and one 132kV line position to connect the customer's line
- Expand JHS with a 230 kV portion including:
  - One 230 kV line position to terminate the newly proposed transmission line from DMR
  - Two 300 MVA 230/132 kV transformers, 132 kV bus work from the transformers to the existing 132 kV bus
  - One 132 kV line position to interconnect the IC's 132 kV bus/line
- Upgrade the existing JHS 132 kV substation to accommodate:
  - One position for the two 132/230 kV step-up transformers
  - One 132 kV line/bus position to interconnect the IC's 132 kV bus/line, which links the IC-installed 230/132 kV step-down transformers to their 230 kV line
- Add one 230 kV line position with associated substation equipment at DMR to terminate the newly proposed transmission line from JHS
- Upgrade required substation facilities, infrastructures, and bus work to support new station equipment at both JHS and DMR
- Supply and install required Protection, Control and Telecommunications equipment

**Exclusions:**

- GST
- Permits
- Right-of-Way & property costs

**Key Assumptions:**

- Construction by contractor
- 30 months of construction is considered
- Execution of early Engineering and Procurement Agreement
- No expansion of existing other stations or control buildings to accommodate new equipment
- No construction during winter season
- Impact Benefit Agreements with First Nations are not considered
- A certificate of public convenience and necessity (CPCN) requirement will be exempt

**Key Risks:**

- Expansion of the existing other substations and/or control building may be required leading to increased costs and/or a longer project schedule
- Major equipment delivery presents potential project cost and schedule risks, based on variance in equipment lead times
- Transmission scope and routing may be different than assumed, including number of structures and types
- Ability to acquire new Right-of-Way
- No defined supply chain strategy; construction costs may increase depending on delivery method
- Project schedule may be longer than expected, leading to increased overhead costs
- Ground improvements may be required leading to increased construction costs
- Contaminated soil may be encountered leading to increased construction costs
- Cost of materials and major equipment may be affected by market conditions and escalation
- If a CPCN is required for the project, it may impact project cost and schedule risks

## **Configuration Consideration**

While the Interconnection Feasibility Study identified potential Network Upgrades based on the requested Point of Interconnection (POI) at the 138 kV level, this configuration is not preferred from BC Hydro's planning perspective. Pursuant to OATT Attachment M-2, Section 4.7 (Interconnection Feasibility Studies), Clause (d), BC Hydro is not permitted to propose an alternate POI during the CEAP process. BC Hydro's preferred approach is for the project to interconnect at the 230 kV level on a nearby circuit.

Please note that the non-technical feasibility of the proposed scope, such as securing additional property and rights-of-way, is unknown, as these considerations are outside the scope of the Interconnection Feasibility Study. Finally, meeting the requested in-service date of October 1, 2033, for the proposed scope would be extremely challenging considering the project delivery risks.

## **Study Limitations and Exclusions**

### ***Protection, Control, and Telecommunications***

The Interconnection Feasibility Study does not include a detailed review of the protection, control, and telecommunications system requirements specific to your Interconnection Request. Based on a high-level review, we have identified proxy costs for protection, control, and telecom Network Upgrades drawn from comparable interconnection projects with similar scope and complexity; these proxy costs have been included solely for indicative budgeting purposes. The relative interconnection cost determined by the Interconnection Feasibility Study includes a telecommunications component based on an assumed solution to deliver teleprotection and telecontrol circuit requirements necessary for the Interconnection Request. Protection, control, and telecommunications system requirements will be reviewed in detail in the System Impact Study if you are a successful participant of the CEAP and meet applicable requirements.

For Interconnection Feasibility Study purposes, it is assumed that any applicant-proposed works that could obstruct or impair the performance of existing BC Hydro microwave systems or new links from the proposed Interconnection Customer Interconnection Facilities (ICIF) to the BC Hydro microwave system would be identified and either relocated or repositioned as determined in a System Impact Study if you are a successful participant of the CEAP and meet applicable requirements. Such works may include, but are not limited to, towers, turbines, dams, support structures, panels, surface materials deposited or redistributed, water surface changes, or vegetation.

### ***Generation Shedding/Curtailment Scheme and Electromagnetic Transient (EMT) Studies***

The generation shedding/curtailment scheme reviews (e.g., Remedial Action Scheme (RAS), and a direct transfer trip for anti-islanding scheme) and EMT studies are completed in a System Impact Study. The outcomes of these studies may result in additional requirements, which could include Network Upgrades or ICIF. Any costs associated with completion of these studies, and resulting requirements, are not included in the Interconnection Feasibility Study cost estimate.

### ***Revenue Metering***

Please note that revenue metering requirements have not been determined with the Interconnection Feasibility Study. As such, any costs associated with revenue metering and other interconnection components are not included in the cost estimate provided above. Once these requirements are defined, costs that are attributable to the Interconnection Customer are to be paid in cash. For more details on revenue metering requirements and responsibilities, please refer to:

<https://www.bchydro.com/content/dam/BCHydro/customer-portal/documents/distribution/standards/ds-rmr-complex-revenue-metering.pdf>.

**Schedule**

Based on the Interconnection Feasibility Study, the non-binding good faith estimated in-service date for your Interconnection Request's Network Upgrades is Quarter 3 2033 (calendar year). To achieve this timeline, we may need to expedite certain activities, including engineering design and procurement of long-lead equipment.

Timely actions required from you to minimize risks to the schedule:

- Submission of additional technical data required for the System Impact Study and Facilities Study
- Submission of any required information or document such as demonstration of Site Control
- Execution of Combined Study Agreement and Standard Generator Interconnection Agreement
- Financial commitments and securities

Please note that changes to your Interconnection Request or delays in data submission or financial commitments may also impact the target in-service date.

If you have any questions, please contact the BC Hydro CEAP team at [ceap2025@bchydro.com](mailto:ceap2025@bchydro.com).

Sincerely,



Manager, Customer Interconnections

BC Hydro

Encl.: CEAP\_2025\_IR104\_ \_Feasibility\_Study.pdf



# Interconnection Feasibility Study

**BC Hydro EGBC Permit to Practice No: 1002449**

**2025 CEAP IR # 104**

Prepared for:



Prepared by:

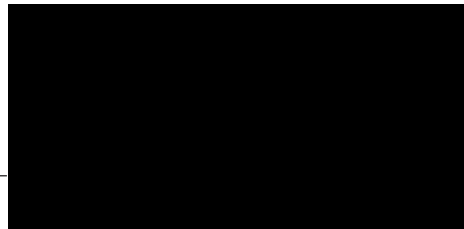

Sr. Engineer, Transmission Planning

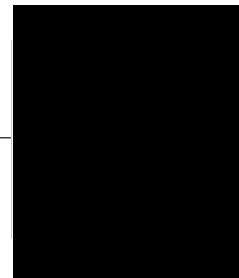

Reviewed by:



Technical Strategic Principle, Transmission

Accepted by:

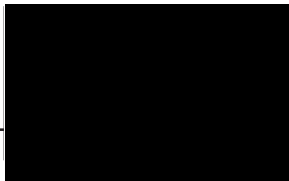

Division Manager, Transmission Planning

## Report Metadata

Header: 2025 CEAP IR # 104  
Subheader: Interconnection Feasibility Study  
Title: [REDACTED]  
Subtitle: 2025 CEAP IR # 104  
Report Number: 550-APR-00018  
Revision: 0  
Confidentiality: Public  
Date: 2025 Nov 21  
Volume: 1 of 1

Prepared for: [REDACTED]  
Prepared by: [REDACTED]  
Title: Sr. Engineer, Transmission Planning  
Checked by: N/A  
Title: N/A  
Reviewed by: [REDACTED]  
Title: Technical Strategic Principle, Transmission Planning

Related Facilities: JHS  
Additional Metadata: Transmission Planning 2025-117  
Filing Subcode 1350

## Revisions

| Revision | Date     | Description     |
|----------|----------|-----------------|
| 0        | 2025 Nov | Initial release |

## Disclaimer of Warranty, Limitation of Liability

This report was prepared solely for internal purposes. All parties other than BC Hydro are third parties.

BC Hydro does not represent, guarantee or warrant to any third party, either expressly or by implication:

any information, product or process disclosed, described or recommended in this report.

BC Hydro does not accept any liability of any kind arising in any way out of the use by a third party of any information, product or process disclosed, described or recommended in this report, nor does BC Hydro accept any liability arising out of reliance by a third party upon any information, statements or recommendations contained in this report. Should third parties use or rely on any information, product or process disclosed, described or recommended in this report, they do so entirely at their own risk.

This report was prepared by the British Columbia Hydro And Power Authority ("BCH") or, as the case may be, on behalf of BCH by persons or entities including, without limitation, persons or entities who are or were employees, agents, consultants, contractors, subcontractors, professional advisers or representatives of, or to, BCH (individually and collectively, "BCH Personnel").

This report is to be read in the context of the methodology, procedures and techniques used, BCH's or BCH's Personnel's assumptions, and the circumstances and constraints under which BCH's mandate to prepare this report was performed. This report is written solely for the purpose expressly stated in this report, and for the sole and exclusive benefit of the person or entity who directly engaged BCH to prepare this report. Accordingly, this report is suitable only for such purpose, and is subject to any changes arising after the date of this report. This report is meant to be read as a whole, and accordingly no section or part of it should be read or relied upon out of context.

Unless otherwise expressly agreed by BCH:

- (a) any assumption, data or information (whether embodied in tangible or electronic form) supplied by, or gathered from, any source (including, without limitation, any consultant, contractor or subcontractor, testing laboratory and equipment suppliers, etc.) upon which BCH's opinion or conclusion as set out in this report is based (individually and collectively, "Information") has not been verified by BCH or BCH's Personnel; BCH makes no representation as to its accuracy or completeness and disclaims all liability with respect to the Information;
- (b) except as expressly set out in this report, all terms, conditions, warranties, representations and statements (whether express, implied, written, oral, collateral, statutory or otherwise) are excluded to the maximum extent permitted by law and, to the extent they cannot be excluded, BCH disclaims all liability in relation to them to the maximum extent permitted by law;
- (c) BCH does not represent or warrant the accuracy, completeness, merchantability, fitness for purpose or usefulness of this report, or any information contained in this report, for use or consideration by any person or entity. In addition, BCH does not accept any liability arising out of reliance by a person or entity on this report, or any information contained in this report, or for any errors or omissions in this report. Any use, reliance or publication by any person or entity of this report or any part of it is at their own risk; and
- (d) In no event will BCH or BCH's Personnel be liable to any recipient of this report for any damage, loss, cost, expense, injury or other liability that arises out of or in connection with this report including, without limitation, any indirect, special, incidental, punitive or consequential loss, liability or damage of any kind.

## Copyright Notice

Copyright and all other intellectual property rights in, and to, this report are the property of, and are expressly reserved to, BCH. Without the prior written approval of BCH, no part of this report may be reproduced, used or distributed in any manner or form whatsoever.

## Contributors

The following accept responsibility for the content in the specified sections. Professionals apply their signature and/or seal as appropriate.

**Section:**

Entire report  
except listed  
below

**Discipline:**

Transmission Planning

Contributed by:



Sr. Engineer, Transmission Planning

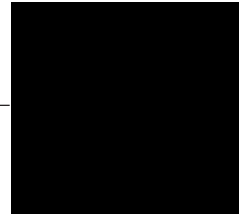

**Section:**

5.2, 5.3

Contributed by:

**Discipline:**

Stations Planning

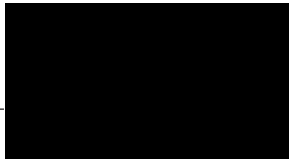

Sr. Engineer, Station Planning

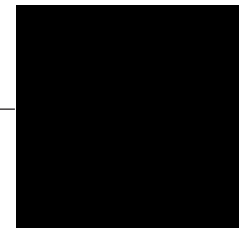

**Section:**

5.4

Contributed by:

**Discipline:**

Transmission Lines Engineering

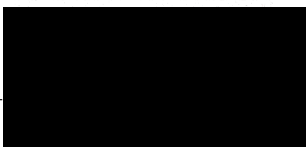

Sr. Engineer, Transmission Lines  
Engineering



## Executive Summary

██████████, the interconnection customer (IC), requests to interconnect its ██████████ Project (2025 CEAP IR # 104) to the BC Hydro system. ██████████ Project has four (4) 125 MW hydro synchronous generators, adding a total capacity of 500 MW with a maximum power injection of 455 MW into the BC Hydro system at the proposed Point of Interconnection (POI). The IC has proposed to connect their Hydro Project to BC Hydro transmission system at the POI, 132 kV bus of the BC Hydro John Hart Substation (JHS), located in North Vancouver Island near Campbell River.

The IC's hydro generation project will be connected via a new 230 kV customer-built transmission line, composed of a 146 km overhead line and a 58 km submarine cable, with two 110 MVAR shunt reactors at the end of the circuit, and step-down to the JHS substation voltage of 132 kV via two customer-installed transformers. The connection method between the IC's 132 kV main bus and the proposed POI at the JHS 132 kV bus is undefined in the Generation Interconnection Data Form (GIDF). For the purpose of this Feasibility (FeS) study, it is assumed that the IC's 132 kV main bus is installed adjacent to the existing JHS substation, and the IC will build a short tie line or bus connecting to the proposed POI at 132 kV bus of JHS. The IC's proposed commercial operation date (COD) is July 7, 2030.

To interconnect the ██████████ Project and its facilities to the BCH transmission system at the proposed POI, this Feasibility Study has made the recommendations and conclusions as follow:

1. The proposed POI at the 132 kV bus of JHS is acceptable to interconnecting the IC's generating project to the BCH system, but it is not optimal for the proposed 455 MW power injection.
2. Performance constraints, such as significant branch overloads under system normal conditions (P0), have been identified for all studied load scenarios (30HW, 30LS and 30HS), caused by the interconnection of the ██████████ Project. Potential reinforcement scope could include: Build one new 230 kV circuit from JHS to Dunsmuir Substation (DMR) (approximately 88 km), install two 300 MVA 132/230 kV transformers at JHS, and expand JHS substation to 230 kV. Further

reinforcement details will be studied under System Impact Study (SIS) stage.

3. The connection of [REDACTED] Project will introduce new thermal overloads on BC Hydro lines 1L119, 1L102, 1L101, and 1L106 under single contingency conditions (P1 or P2) across all studied load scenarios (30HW, 30LS and 30HS). These overloads were not present prior to the IC's connection and are not addressed by existing remedial action schemes (RAS). As a result, the IC's generators are required to participate as generation shedding candidates at a new generation shedding RAS. Further RAS details will be studied under SIS stage.
4. The [REDACTED] Project is required to install anti-islanding protection within its facility to disconnect the IC's generating plant from the grid when an inadvertent island with the local load forms. The anti-islanding protection shall be configured in the manner that does not compromise the required ride-through performance.
5. The [REDACTED] Project must meet BC Hydro's reactive power requirements for synchronous generators, as outlined in Section 6.4.2 of the Technical Interconnection Requirements. Specifically, each unit must operate continuously within a power factor range of 0.90 over-excited to 0.95 under-excited, measured at the generator terminals. Based on the PSS/E model and the Hydro Generator Capability Curves submitted by the Interconnection Customer, the project meets this requirement.

The above conclusions are made based on the IC's input data and study assumptions listed in Section 4, which represent the best available information on October 14, 2025.

A non-binding good faith cost for required network upgrades and estimated schedule for construction are included in a separate letter to the IC.

Please note that, this Feasibility Study report does not include the descriptions of Protection, Control, and Telecommunications requirements and the associated upgrade scopes; however, as discussed in Section 2 "Purpose and Scopes of Study, the associated cost implications are captured and delivered in the cover letter to the IC".

# Contents

|  |           |
|--|-----------|
| <b>Executive Summary</b>                   | <b>vi</b> |
| <b>1 Introduction</b>                      | <b>1</b>  |
| <b>2 Purpose and Scopes of Study</b>       | <b>4</b>  |
| <b>3 Standard and Criteria</b>             | <b>5</b>  |
| <b>4 Assumptions and Conditions</b>        | <b>6</b>  |
| <b>5 System Studies and Results</b>        | <b>8</b>  |
| 5.1 Power Flow Study Results               | 8         |
| 5.1.1 Thermal Overload Analysis            | 8         |
| 5.1.2 Steady-State Voltage Analysis        | 10        |
| 5.1.3 Reactive Power Capability Evaluation | 10        |
| 5.1.4 Anti-Islanding Requirements          | 10        |
| 5.2 Fault Analysis                         | 10        |
| 5.3 Stations Requirements                  | 11        |
| 5.4 Transmission Line Requirements         | 11        |
| <b>6 Cost Estimate and Schedule</b>        | <b>12</b> |
| <b>7 Conclusions</b>                       | <b>13</b> |

## Appendices

|            |                                       |
|------------|---------------------------------------|
| Appendix A | Schematic Diagram of the IC's Project |
| Appendix B | Power Flow Study Results              |
| Appendix C | One-Line Sketch for Station Scope     |

## Acronyms

The following are acronyms used in this report.

|      |   |
|------|---|
| BCH  | BC Hydro  |
| BKB  | Buckley Bay Substation                          |
| █    | █ Generation                                    |
| █    | █ Switching Station                             |
| CBL  | Campbell River Substation                       |
| CMX  | Comox Substation                                |
| CSS  | Cape Scott Wind Generating Station              |
| CEAP | Competitive Electricity Acquisition Process     |
| COD  | Commercial Operation Date                       |
| DTT  | Direct Transfer Trip                            |
| DMR  | Dunsmuir Substation                             |
| ERIS | Energy Resource Interconnection Service         |
| FeS  | Feasibility Study                               |
| IBR  | Inverter-Based Resources                        |
| IC   | Interconnection Customer                        |
| IR   | Interconnection Request                         |
| GIDF | Generation Interconnection Data Form            |
| GLD  | Gold River Substation                           |
| JHS  | John Hart Substation                            |
| KKS  | █-Koskish River Generating Station              |
| MPO  | Maximum Power Output                            |
| NERC | North American Electric Reliability Corporation |
| NRIS | Network Resource Interconnection Service        |
| NVI  | North Vancouver Island                          |
| OATT | Open Access Transmission Tariff                 |
| OYR  | Oyster River Substation                         |
| OOS  | Out-of-Service                                  |
| POI  | Point of Interconnection                        |
| RAS  | Remedial Action Scheme                          |
| RoW  | Right of Way                                    |

SCA Strathcona Substation  
TIR BC Hydro “60 KV to 500 kV Technical Interconnection Requirements for  
Power Generators”  
TVC Transmission Voltage Customer  
VIC Virtual Inertia Control  
WECC Western Electricity Coordinating Council



Figure 1-1 illustrates the North Vancouver Island (NVI) regional 132/230 kV transmission system. This area is rich in generation resource, hosting the majority of Vancouver Island’s power production. The 230 kV system connects the Gold River (GLD) and Dunsmuir (DMR) substations, with Dunsmuir serving as the key link to the broader transmission network. Operating in parallel, the 132 kV system spans the length of NVI—from Dunsmuir to Gold River, and further extended to Port Hardy—and complements the 230 kV system by serving nearly all the generation and load in the region.

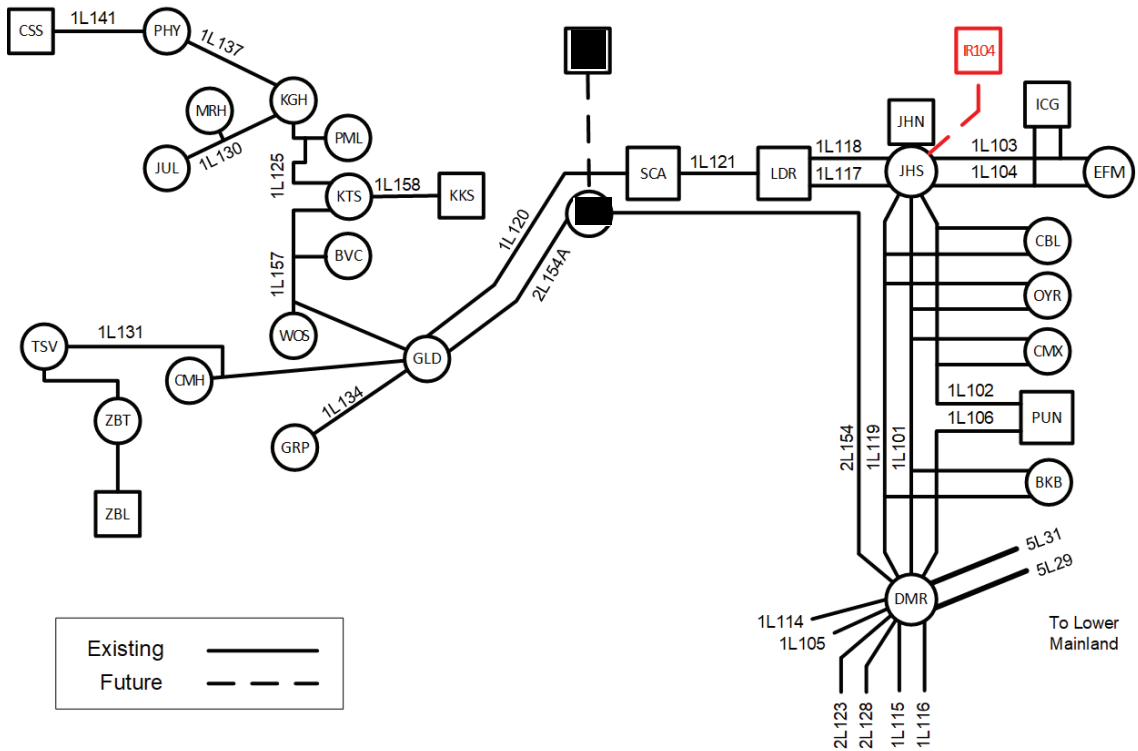

Figure 1-1: North Vancouver Island Region 132/230 kV Transmission System Diagram

The NVI region 132/230 kV system has existing branch overload concerns under contingency conditions. These constraints are primarily driven by excessive generations in the region. A remedial action scheme (RAS), named the North Vancouver Island Remedial Action Scheme (NVI RAS), is implemented to address the thermal overloads on 1L120 (GLD-SCA) and other 132 kV lines under the contingency of loss 2L154 (GLD-DMR) during high generation conditions. This RAS will runback the Cape Scott Wind generating station (CSS) and [REDACTED]-Koskish River Generating Station (KKS) generations.

In addition, a new wind farm, [REDACTED] will be added to the NVI region. To interconnect [REDACTED] to the BC Hydro system, a new switching station [REDACTED] will be constructed on transmission line 2L154, near Strathcona Substation (SCA). [REDACTED] will also participate in the NVI RAS.

There are no relevant capital projects or confirmed load interconnections in the study area.

## 2 Purpose and Scopes of Study

This Feasibility Study is a preliminary evaluation of the system impact of interconnecting the proposed project to the BC Hydro system based on power flow and short circuit analysis in accordance with BCH's Open Access Transmission Tariff (OATT) and produces the estimated cost of required Network Upgrades and the implementation schedule.

Per OATT, the Feasibility Study is performed individually for each of the participating projects in the CEAP process and focuses specifically on the BC Hydro regional transmission system where the proposed generating project is connected and affects.

This is a "limited scope" study which is restricted to power flow studies of P0, P1 and P2 planning events as defined in TPL-001-4 and short circuit analysis. The study does not address other technical aspects such as transient stability and switching transients and impact of multiple contingencies. These subjects will be addressed in subsequent System Impact Study (SIS) if the project proceeds further. In addition, any potential impacts to the adjacent external systems to BC Hydro would be addressed in subsequent detailed and coordinated studies with the relevant adjacent entities if the proposed generator project proceeds further.

Please note that, due to the compressed study timeline for CEAP 2025 Feasibility Study, this report does not include the descriptions of the Protection, Control, and Telecommunication requirements and the associated upgrade scopes. Instead, the network upgrades associated with Protections, Controls and Telecommunications are incorporated with cost estimates in a separate cover letter to the IC.

### 3 Standard and Criteria

The Feasibility Study is performed in compliance with the North American Electric Reliability Corporation (NERC) and Western Electricity Coordinating Council (WECC) reliability standards, and the BCH interconnection requirements in the TIR, and upon the ratings of the existing BCH transmission facilities described in Operating Orders, specifically:

- NERC standards: TPL-001-4 and FAC-002-3 relevant to the scope of this Feasibility Study.
- WECC criteria TPL-001-WECC-CRT-4 Transmission System Planning Performance, July 1, 2023.
- BC Hydro's 60 kV to 500 kV Technical Interconnection Requirements for Power Generators, Rev 2.1.1, Effective: Sept 22, 2025.
- BC Hydro Operating Order 5T-10, Ratings for All Transmission Circuits 60 kV or Higher, Sept 17, 2025.
- BC Hydro Operating Order 5T-14, Ratings for All Transmission and Distribution Transformer, Sept 22, 2025.
- BC Hydro System Operating Order 7T-22 System Voltage Control, Sept 19, 2023.

## 4 Assumptions and Conditions

This Feasibility Study is performed based on the IC's submitted data and information available to BC Hydro on Oct 14, 2025, for the study purpose. Assumptions are made wherever the IC's input is unavailable. Appendix A shows the schematic diagram of the IC's project used in the study model.

The power flow study cases used in this Feasibility Study are established based upon the BC Hydro's base resource plan and load forecasts available at the time of performing the study, which includes existing and future generators, transmission facilities, and loads in addition to the subject interconnection project in this study. Applicable seasonal conditions and the appropriate study years for the study planning horizon are also incorporated. Additional assumptions are listed as follows.

- 1) The generation in the North Vancouver Island region area are dispatched to the patterns that stress the transmission system in the study area. In these patterns, the associated generators are typically set to Maximum Power Outputs (MPO) unless otherwise specified.
- 2) The 2024 Distribution Substation Load Forecast, 2025 Transmission Voltage Customer (TVC) Load Forecast and 2025 System Peak Forecast are used.
- 3) September 2024 Base Resource Plan.
- 4) 197.2 MW [REDACTED] will be in service on December 31, 2028.
- 5) 30HW, 30HS and 30LS are used as base case in the study to evaluate system impact after [REDACTED] Project plant interconnection.
- 6) Assume adequate right-of-way is available to BC Hydro for implementing potential reinforcement options.
- 7) Assume the IC is responsible to build their voltage conversion facilities, including the 230/132kV step down transformers as required, and interconnect their facilities to the proposed POI.
- 8) The connection method between the IC's 132 kV main bus and the proposed POI at the JHS 132 kV bus is undefined in the GIDF. For the

purpose of this FeS study, it is assumed that the IC's 132 kV main bus is installed adjacent to the existing JHS substation, and IC will build a short tie line or bus connecting to the proposed POI at 132 kV bus of JHS.

## 5 System Studies and Results

### 5.1 Power Flow Study Results

Power flow studies were performed to evaluate whether the IC's generating project would cause any unacceptable system performance (e.g. equipment overloads, steady-state voltage violation and voltage instability) and to determine the system reinforcement requirement based on steady state performance analysis.

The study focuses on the base scenarios — 30HW/30LS/30HS system conditions that includes all the higher-queued generating projects (██████████) in the North Vancouver Island region. These base cases were prepared based on factors such as load conditions, seasonal variation in ambient temperatures, and generation patterns that stress the transmission system.

The studies were performed for system normal conditions and under critical system contingencies specified in the P1 and P2 events by NERC TPL-001-4. Study results are summarized below.

#### 5.1.1 Thermal Overload Analysis

The study identified significant branch overloads under system normal condition (P0) and contingency conditions (P1 & P2) for all the studied load conditions (30HW, 30LS and 30HS).

JHS is connected to five 132 kV circuits. During peak generation, two circuits (1L117, 1L118) deliver power into JHS, while the other three (1L101, 1L102, 1L119) export power out from JHS. These three also supply downstream stations including Campbell River Substation (CBL), Oyster River Substation (OYR), Comox Substation (CMX), Buckley Bay Substation (BKB), and the boarder system through DMR. Based on the current system configuration, the existing infrastructure, particularly the three circuits from JHS to DMR, is not capable of supporting this additional generation during peak generation scenarios under system normal condition.

The study identified that the interconnection of the IC's generation project triggers critical branch overloads on lines 1L119, 1L102, 1L101, and 1L106 under system normal and single contingency conditions (i.e. P0, P1 or P2) across all studied load scenarios (30HW, 30LS and 30HS).

Figure 5-1 illustrates the potential reinforcement scope to mitigate the thermal constraint identified under system normal and single contingencies conditions.

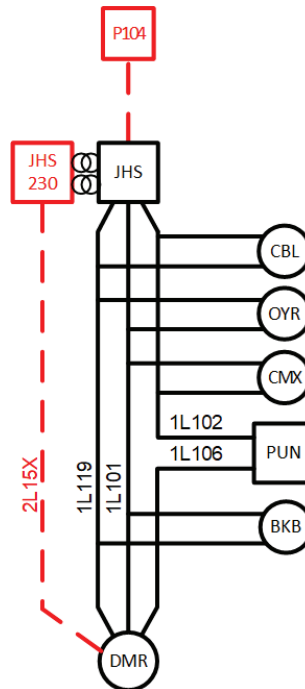

Figure 5-1: Potential System Reinforcement for the IR104 Interconnection

Potential system reinforcement: A new 230 kV circuit from JHS to DMR with transformation to 132 kV at JHS (temporarily designated as 2L15X).

- Build one new 230 kV circuit, 2L15X from JHS to DMR, approximately 88 km. The minimum continuous ampacity rating of 230 kV circuit should be sized with a minimum summer rating of 1205 Amps to meet or exceed the IC's maximum power injection at POI, considering cost-benefit trade-offs across various conductor sizes.
- At JHS, install two 300 MVA 132/230 kV step-up transformers to match IC's maximum power injection at POI. The size and number of transformers can be optimized during the further System Impact Study stage.
- A new generation shedding RAS is required to trip or curtail the IC's hydro generations at their site substation under single or multiple contingencies, loss of 2L154, 2L154A or 2L15X, loss of one or more 132 kV lines from JHS to DMR, DMR\_1B1 (or 1B3) bus fault, DMR\_132kV breaker internal fault. The detailed RAS requirements will be confirmed during the System Impact Study stage, if necessary.

Details of the thermal overload analysis are provided in Appendix B.

### **5.1.2 Steady-State Voltage Analysis**

The study identified that the IC's generation project contributes to the low voltage performance concerns at GLD 230 under light summer conditions (30LS).

There is an existing system performance concern under a 132 kV internal breaker fault at DMR. The connection of the IC's project exacerbates this existing issue, contributing to potential voltage instability in the NVI region.

The proposed reinforcement plans, along with the new generation shedding RAS or modified NVI RAS, will be relied upon to mitigate these low-voltage and voltage instability concerns.

Appendix B shows the details in the steady-state voltage study results.

### **5.1.3 Reactive Power Capability Evaluation**

The [REDACTED] Project must meet BC Hydro's reactive power requirements for synchronous generators, as outlined in Section 6.4.2 of the Technical Interconnection Requirements. Specifically, each unit must operate continuously within a power factor range of 0.90 over-excited to 0.95 under-excited, measured at the generator terminals. Based on the PSS/E model and the Hydro Generator Capability Curves submitted by the Interconnection Customer, the project meets this requirement.

### **5.1.4 Anti-Islanding Requirements**

[REDACTED] Project is not arranged for islanded operation. In addition, the IC is required to install anti-islanding protection within its facility to disconnect the IC's generators from the grid when an inadvertent island with the local loads' forms.

## **5.2 Fault Analysis**

The short circuit analysis in the FeS is based upon the latest BC Hydro system model, which includes the generating facility information and associated impedance data provided by the IC. A more detailed study will be performed at the System Impact Study stage if needed.

### 5.3 Stations Requirements

The station upgrade scope at the JHS is as follows:

- Expand JHS with a 230 kV portion inside the station fence or BCH property including:
  - Provide one (1) 230 kV line position to terminate the transmission line 2L15X from DMR.
  - Add two (2) 300 MVA 230/132 kV transformers.
  - Add 132 kV bus work from the transformers to the existing 132 kV bus.
- Install one (1) 132 kV line position to interconnect the IC's 132 kV bus/line.

The station upgrade scope at the DMR is as follows:

- Provide one (1) 230 kV line position to terminate the transmission line 2L15X from JHS.

Notes:

- JHS currently does not have 230 kV facilities and needs expansion to add the 230 kV portion inside the station fence or BCH property.
- Assumption:
  - Assume that the space is available within the station fence or BCH property to accommodate the expansion for 230 kV portion.
  - Assume there is space available for relevant P&C equipment.

### 5.4 Transmission Line Requirements

Transmission line engineering scope of work for BC Hydro is as below:

- Build one new 230 kV circuit from JHS to DMR (approximately 88 km), with minimum ampacity ratings of 1205 Amps (summer and winter). New Right of Way (RoW) is required.

## 6 Cost Estimate and Schedule

The non-binding good faith estimated cost and time to construct the Network Upgrades required to interconnect the proposed project will be provided in a separate letter to the IC.

## 7 Conclusions

To interconnect the [REDACTED] Project and its facilities to the BCH Transmission System at the proposed POI, this Feasibility Study has identified the following conclusions and requirements:

1. The proposed POI at the 132 kV bus of JHS is acceptable to interconnect the IC's generating project to the BCH system. However, it is not optimal for the proposed 455 MW power injection.
2. Performance constraints, such as significant branch overloads under system normal conditions (P0), have been identified for all studied load scenarios (30HW, 30LS and 30HS), caused by the interconnection of the [REDACTED] Project. Potential reinforcement scope could include: Build one new 230 kV circuit from JHS to DMR (approximately 88 km), install two 300 MVA 132/230 kV transformers at JHS, and expand JHS substation to 230 kV. Further reinforcement details will be studied under SIS stage.
3. The connection of [REDACTED] Project will introduce new thermal overloads on BC Hydro lines 1L119, 1L102, 1L101, and 1L106 under single contingency conditions (P1 or P2) across all studied load scenarios. These overloads were not present prior to the IC's connection and are not addressed by existing RAS. As a result, the IC's generators are required to participate as generation shedding candidates at a new generation shedding RAS. Further RAS details will be studied under System Impact Study stage.
4. The [REDACTED] Project is required to install anti-islanding protection within its facility to disconnect the IC's generating plant from the grid when an inadvertent island with the local load forms. The anti-islanding protection shall be configured in the manner that does not compromise the required ride-through performance.
5. The [REDACTED] Project must meet BC Hydro's reactive power requirements for synchronous generators, as outlined in Section 6.4.2 of the Technical Interconnection Requirements. Specifically, each unit must operate continuously within a power factor range of 0.90 over-excited to 0.95 under-excited, measured at the generator terminals.

Based on the PSS/E model and the Hydro Generator Capability Curves submitted by the Interconnection Customer, the project meets this requirement.



## Appendix A

### Schematic Diagram of the IC's Project

Figure A-1 shows the schematic diagram for the [REDACTED] Project.

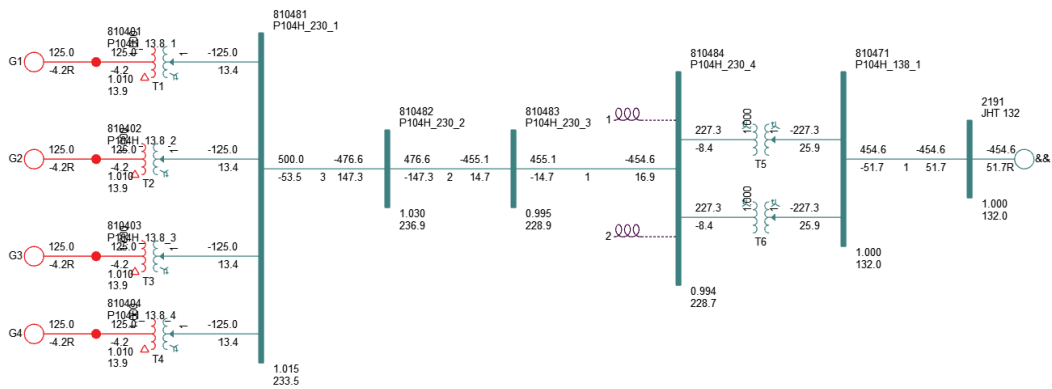

Figure A-1: [REDACTED] Project Plant Schematic Diagram.

## Appendix B

### Power Flow Study Results

#### Base Scenario (30HW/30HS/30LS)

**Table B-1: Thermal Overload Study Results**

| Cases | IC's Gen Output (MW) | Contingency Identified |                               | Branch Loading (Amps) |                  |                  |                 |  |
|-------|----------------------|------------------------|-------------------------------|-----------------------|------------------|------------------|-----------------|--|
|       |                      |                        |                               | 1L119                 | 1L102            | 1L101            | 1L106           | 2L154A   |
|       |                      | Cate                   | Description                   | JHS-CBL               | JHS-CBL          | JHS-OYR          | PUN-DMR         | GLD <span style="background-color: black; color: black;">████</span> |
|       |                      | Winter Ratings         |                               | 800                   | 800              | 805              | 600             | 844  |
| 30HW  | Max                  | P0                     | System Normal                 | 1008.7<br>126.1%      | 978.1<br>122.3%  | 874.1<br>109.3%  | 606.3<br>101.1% | 387.6<br>45.9%   |
|       |                      | P1                     | 2L154A OOS w RAS <sup>1</sup> | 1027.0<br>128.4%      | 996.8<br>124.6%  | 892.6<br>111.6%  | 624.4<br>104.1% | -  |
|       |                      | P2                     | 1L102.CBL                     | 1650.1<br>206.3%      | -                | 1113.8<br>139.2% | 251.8<br>42.0%  | 471.8<br>55.9%   |
|       |                      | Summer Ratings         |                               | 650                   | 686              | 625              | 600             | 844  |
| 30HS  | Max                  | P0                     | System Normal                 | 978.2<br>150.5%       | 950.3<br>138.5%  | 908.3<br>145.3%  | 789.7<br>131.6% | 493.4<br>58.5%   |
|       |                      | P1                     | 2L154A OOS w RAS <sup>1</sup> | 1044.7<br>160.7%      | 1018.4<br>148.5% | 976.1<br>156.2%  | 856.2<br>142.7% | -  |
|       |                      | P2                     | 1L102.CBL                     | 1606.6<br>247.2%      | -                | 1151.0<br>184.2% | 442.0<br>73.7%  | 581.4<br>68.9%   |
| 30LS  | Max                  | P0                     | System Normal                 | 957.4<br>147.3%       | 941.7<br>137.3%  | 933.6<br>149.4%  | 869.3<br>144.9% | 541.2<br>64.1%   |
|       |                      | P1                     | 2L154A OOS w RAS <sup>1</sup> | 1041.1<br>160.2%      | 1027.7<br>149.8% | 1019.3<br>163.1% | 953.3<br>158.9% | -  |
|       |                      | P2                     | 1L102.CBL                     | 1583.1<br>243.5%      | -                | 1176.1<br>188.2% | 524.9<br>87.5%  | 630.0<br>74.6%   |

<sup>1</sup> Existing NVI RAS, excluding the IC's participation.

**Table B-2: Steady-State Voltage Study Results**

| Case     | IC's<br>Generator<br>Output<br>(MW) | Contingency |                               | Bus Voltage (PU) |            |            |            |            |
|----------|-------------------------------------|-------------|-------------------------------|------------------|------------|------------|------------|------------|
|          |                                     | Cate.       | Description                   | DMR<br>230       | DMR<br>132 | JHS<br>132 | GLD<br>132 | GLD<br>230 |
| 30H<br>W | Max                                 | P0          | System Normal                 | 1.034            | 1.043      | 1.039      | 1.068      | 1.009      |
|          |                                     | P1          | 2L154A OOS w RAS <sup>1</sup> | 1.035            | 1.043      | 1.037      | 1.065      | -          |
|          |                                     | P2          | 1L102.CBL                     | 1.027            | 1.046      | 1.030      | 1.069      | 1.002      |
| 30HS     | Max                                 | P0          | System Normal                 | 1.007            | 1.047      | 1.037      | 1.066      | 0.974      |
|          |                                     | P1          | 2L154A OOS w RAS <sup>1</sup> | 1.013            | 1.049      | 1.033      | 1.072      | -          |
|          |                                     | P2          | 1L102.CBL                     | 1.010            | 1.060      | 1.029      | 1.066      | 0.938      |
| 30LS     | Max                                 | P0          | System Normal                 | 1.006            | 1.043      | 1.033      | 1.065      | 0.949      |
|          |                                     | P1          | 2L154A OOS w RAS <sup>1</sup> | 1.014            | 1.046      | 1.027      | 1.072      | -          |
|          |                                     | P2          | 1L102.CBL                     | 1.007            | 1.055      | 1.024      | 1.063      | 0.911      |
| 30LS     | 0                                   | P0          | System Normal                 | 1.034            | 1.043      | 1.039      | 1.068      | 1.009      |

## Appendix C

### One-Line Sketch for Station Scope

Figure C-1 and Figure C-2 show the Stations Planning One-Line Sketch for the Station scope at JHS and DMR.

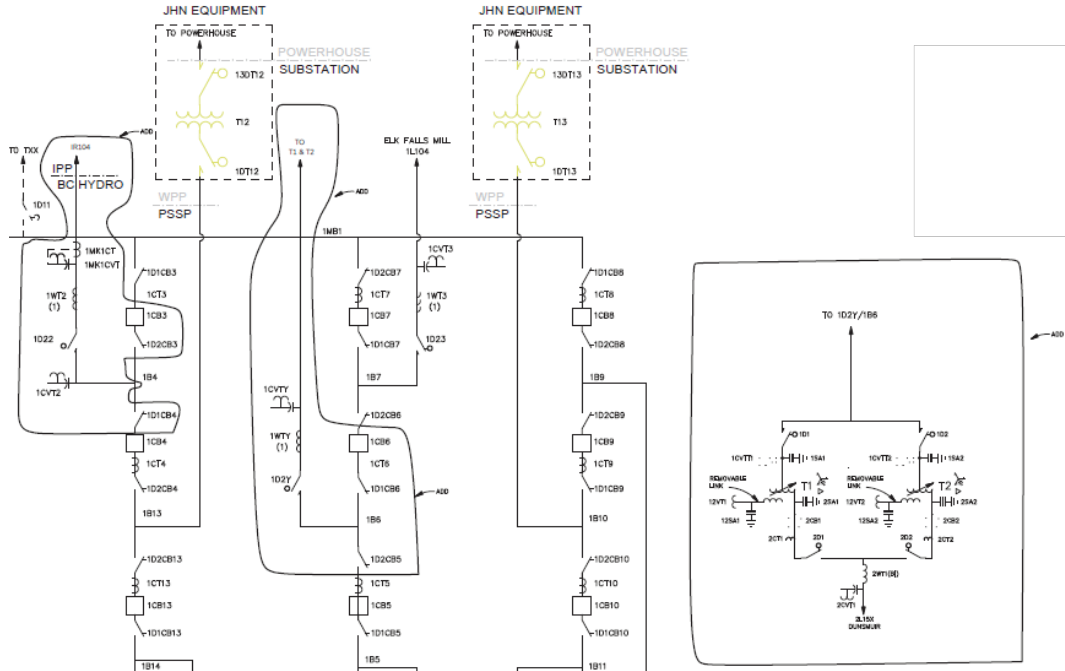

Figure C-1: Stations Planning One-Line Sketch for Station Scope at JHS.

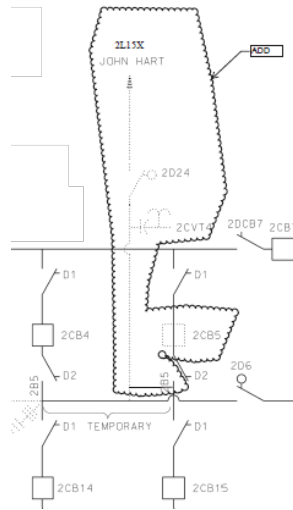

Figure C-2: Stations Planning One-Line Sketch for Station Scope at DMR.