

6911 Southpoint Drive (B03)
Burnaby, BC
V3N 4X8

September 26, 2025

[REDACTED]

via electronic mail: [REDACTED]

Dear [REDACTED],

RE: [REDACTED] Project - Interconnection System Impact Study Report

Enclosed is the Interconnection System Impact Study report for the proposed [REDACTED] project submitted under Attachment M-1: Standard Generator Interconnection Procedures (SGIP) including Standard Generator Interconnection Agreement (SGIA) of the Open Access Transmission Tariff (OATT).

This letter provides a non-binding good faith estimate of the cost and time to construct the facilities required to interconnect your project to BC Hydro's Transmission System, being the Network Upgrades, based on the findings of the Interconnection System Impact Study.

Open Access Transmission Tariff

The OATT defines Network Upgrades as additions, modifications, and upgrades to BC Hydro's Transmission System required at or beyond the Point of Interconnection (POI) to accommodate the interconnection of the Generating Facility to the BC Hydro's Transmission System. Pursuant to the OATT, BC Hydro will design, procure, construct, install, and own the Network Upgrades. While BC Hydro will pay the costs for the Network Upgrades, the Interconnection Customer provides security for such costs.

Cost Estimate

The total cost to deliver BC Hydro's System Impact Study (SIS) scope based on the cluster System Impact Study performed for [REDACTED] and [REDACTED] Interconnection Requests is \$150.1 M.

The non-binding good faith estimated cost (typical accuracy range of +100%/-35%) for Network Upgrades required to interconnect your Interconnection Request ([REDACTED]) is **\$66.8M**.

Furthermore, the non-binding good faith estimated cost for the Network Upgrades for your Interconnection Request represents an approximation of the portion attributable to your share of the total cost to deliver BC Hydro's System Impact Study (SIS) scope. Cost sharing between the two Interconnection Requests is based on an equal 50/50 split, with the exception of the transmission line scope which has been allocated proportionally according to each Interconnection Request's Generating Facility Capacity. The portion of the total costs to deliver BC Hydro's SIS scope allocated to your Interconnection Request will be further refined upon completion of the Facilities Study.

Major Scope of Work Identified (Combined Scope for [REDACTED] and [REDACTED] Projects):

Stations – [REDACTED] Transmission Switching Station (KBTX)

- Construct a new outdoor 138kV, 4-circuit breaker ring bus switching station. Four circuit breakers and associated disconnects shall be rated at 3000A.
- Acquire property for a new KBTX switching station.
- Install four 138 kV line terminals associated motorized disconnects, surge arresters and capacitor voltage transformers
- Install single phase 138 kV station service VTs.
- Install a diesel generator for station service backup.
- Construct a new control building and other required substation structures.

Stations – Nicola Substation (NIC)

- Replace 1L244 line jumpers to 1D31 with 2000 A rating conductors.

Transmission – 1L244 Line Upgrade (Required for Stage 2 – See Key Assumptions)

- All work relating to and including the reconductoring of 1L244 between NIC and KBTX.
- New 138kV pole line constructed parallel to existing 1L244 circuit (approx. 32.4km).

Protection and Control

- Provide line protection and associated Remedial Action Scheme (RAS) at NIC and KBTX Substations.
- Modify Westbank Substation (WBK) line protection (Required for Stage 3 – See Key Assumptions).
- Modify [REDACTED] (PSW) line protection.
- Full new control system at KBTX.

Telecommunications

- Perform a tower study, install tower, four waveguides, and two antennas at Hamilton Microwave Station (HAM)
- Install tower, two waveguides, and antenna facing HAM at KBTX.
- Perform tower study, install two waveguides and antenna facing HAM at Nicola Substation (NIC).

Exclusions:

- GST
- Outage costs.
- Permits
- Cost change due to currency fluctuations.
- Impact Benefit Agreements are not considered.
- Properties cost for right of way.
- Site-specific requirements including but not limited to dewatering, ground improvements, slope stabilization, etc.
- Project acceleration costs that may be needed to compress schedule.
- Book value of decommissioned equipment.
- Site-specific requirements for the new passive repeater site including but not limited to ground improvements, slope stabilization, etc.
- Demolition of decommissioned section of the existing 1L244 line from KBTX to NIC.
- 1L244 undercrossing of 5L098 to allow ingress and egress to KBTX.

Key Assumptions:

The estimate is based on these key assumptions:

- Both [REDACTED] and [REDACTED] projects will connect to KBTX.
- The scope project will be delivered in three stages:
 - Stage 1: [REDACTED] enters service (Proposed COD: Sept 2028)
 - Stage 2: at or before the time [REDACTED] enters service (Proposed COD: Oct 1, 2031)
 - Stage 3: at or before the time the West Kelowna Transmission Project (WKTP) enters service (Target ISD: Nov 30, 2032)
- The new transmission line shall run parallel to the existing Right of Way for 1L244. The Right of Way will be widened by an additional ~25m to accommodate this new line.
- The preliminary telecom scope of work does not follow a staged approach, it is assumed that all work must be complete in time for Stage 1.
- Project location assumed to be a greenfield site with no contamination or demolition required.
- Properties costs assume that 4 hectares of land are required for the switching station and interconnection. No in-depth market transaction research has been conducted on land values, which may vary significantly depending on location, amenities, and market conditions.
- Construction to be subcontracted to an external party (Contractor).
- Contractor(s) to take on prime contractor responsibility.
- Environmental assessment certificate not required for this project.
- Camp will not be required; crew will be based out of nearest city/town.
- No expansion of existing station or control building to accommodate new equipment.
- Interconnection Customer to design and build the last span connecting to KBTX at BC Hydro's cost after review and approval.
- Station location assumed to be within 1 KM of a viable access highway/road.
- Outage windows needed to reconfigure the 1L244 will be accepted by BC Hydro Operations for all stages.
- Up to 100m of the existing line will need to be decommissioned for Stage 1 which will involve removing some conductor, hardware, and up to two existing structures.
- For RAS and RAS associated lines, only a high-level allowance was considered. As the final RAS system architecture will be the result of an iterative optimization and design process between Transmission Operation Services, Telecom and P&C in a later period of the project.

Key Risks:

- Project schedule may be longer than expected, leading to increased costs.
- Additional right of way may be required to accommodate the ingress and egress of the line or other equipment.
- No in-depth market transaction research has been conducted on land values, which may vary significantly depending on location, amenities, and market conditions.
- Delays in receiving documentation or funding from the Interconnection Customers which may delay key milestones.
- Major equipment delivery presents potential project cost and schedule risks, based on variance in equipment lead times.
- No defined supply chain strategy at this stage.
- Cost of construction may increase based on geotechnical condition of the actual project site.
- Telecom scope presents high risk of change due to rapidly evolving technologies and standards.
- Cost of materials and major equipment may be affected by market conditions and escalation.

Technical Interconnection Requirements and Revenue Metering Requirements

As part of our commitment to maintaining a reliable and responsive grid, BC Hydro maintains its Technical Interconnection Requirements (TIR) documentation (updated in September 2025). You will be required to meet the TIR as your project will be connecting to the BC Hydro Transmission system. Revisions to the TIR made in recent years include new provisions for Inverter-Based Resources (IBRs), which are required to participate in primary frequency regulation. BC Hydro looks forward to working closely with you so that you can meet the TIR and can assist with any technical questions you may have. For more details on the TIR, please refer to:

<https://app.bchydro.com/content/dam/BCHydro/customer-portal/documents/transmission/tgi/60kv-500kv-TIR-for-power-generators.pdf>

The Revenue Metering requirements to interconnect your project have been identified in the System Impact Study report. However, the Revenue Metering costs are not included in the above estimate as they are separate from the cost of Network Upgrades. Revenue Metering costs that are attributable to the Interconnection Customer are to be paid in cash. For more details on Revenue Metering requirements and responsibilities, please refer to:

<https://www.bchydro.com/content/dam/BCHydro/customer-portal/documents/distribution/standards/ds-rmr-complex-revenue-metering.pdf>.

Schedule

Based on the Interconnection System Impact Study, the non-binding good faith estimated in-service date for Stage 1 of your project's Network Upgrades is **Quarter 2, 2028** to align with the requested in-service date from your Interconnection Request. The non-binding good faith estimated in-service date for Stage 2 is Quarter 2, 2031 and for Stage 3 Quarter 4, 2032. To achieve this timeline, we may need to expedite certain activities, including engineering design and procurement of equipment; the expediting of activities may result in increased costs.

Timely actions required from you for the rest of the interconnection process to minimize risks to the schedule:

- Submission of any additional required technical data
- Submission of any required information or documents such as demonstration of Site Control
- Execution of a Standard Generator Interconnection Agreement
- Providing Financial commitments and securities, as required

Please note that changes to your interconnection request, delays in data submission or financial commitments may also impact the target in-service date.

Next Steps

In fall 2025, we are targeting to issue a final invoice for the System Impact Study costs. This invoice will reflect the total amount due or amount to be refunded, taking into account the System Impact Study deposits already paid.

Should you wish to discuss the contents of the SIS report, BC Hydro can arrange for an optional SIS Review Meeting. After the SIS Review meeting, BC Hydro will provide you with a cost estimate for the Facilities Study and any additional data requirements. After being provided with the cost estimate, we ask that you provide written confirmation to proceed with the Facilities Study.

In addition to the confirmation, you will be required to provide additional data for the Facilities Study.

If you have any questions, please contact Transmission Generator Interconnections team at transmission.generators@bchydro.com.

Sincerely,

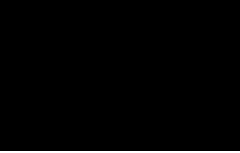

Interconnections Manager, Transmission Generator Interconnections

BC Hydro

Encl.: [REDACTED] SIS_Report_Redacted.pdf

CC: [REDACTED]

[Redacted] Project and [Redacted] Project
Interconnection System Impact Study

BC Hydro EGBC Permit to Practice No: 1002449

[Redacted]

Prepared for: [Redacted]

Prepared by: [Redacted]

Specialist Engineer, Interconnection
Planning

Reviewed by: [Redacted]

Manager, Interconnection Planning

Accepted by: [Redacted]

Manager, Transmission Planning

Report Metadata

Header: [REDACTED] Project and [REDACTED] Project
Subheader: Interconnection System Impact Study
Title:
Subtitle: [REDACTED]
Report Number: 450-APR-00002
Revision: 0
Confidentiality: Public
Date: 2025 Sep 16
Volume: 1 of 1

Prepared for: [REDACTED]
Prepared by: [REDACTED]
Title: Specialist Engineer, Interconnection Planning
Checked by: [REDACTED]
Title: Senior Engineer, Interconnection Planning
Reviewed by: [REDACTED]
Title: Manager, Interconnection Planning

Related Facilities: Facility station code – K2W
Facility station code – BEW
Line designation – 1L244

Additional Metadata: Transmission Planning 2025-028
Filling subcode 1350

Revisions

Revision	Date	Description
0	2025 Sept	Initial release

Disclaimer of Warranty, Limitation of Liability

This report was prepared solely for internal purposes. All parties other than BC Hydro are third parties.

BC Hydro does not represent, guarantee or warrant to any third party, either expressly or by implication:

any information, product or process disclosed, described or recommended in this report.

BC Hydro does not accept any liability of any kind arising in any way out of the use by a third party of any information, product or process disclosed, described or recommended in this report, nor does BC Hydro accept any liability arising out of reliance by a third party upon any information, statements or recommendations contained in this report. Should third parties use or rely on any information, product or process disclosed, described or recommended in this report, they do so entirely at their own risk.

This report was prepared by the British Columbia Hydro And Power Authority ("BCH") or, as the case may be, on behalf of BCH by persons or entities including, without limitation, persons or entities who are or were employees, agents, consultants, contractors, subcontractors, professional advisers or representatives of, or to, BCH (individually and collectively, "BCH Personnel").

This report is to be read in the context of the methodology, procedures and techniques used, BCH's or BCH's Personnel's assumptions, and the circumstances and constraints under which BCH's mandate to prepare this report was performed. This report is written solely for the purpose expressly stated in this report, and for the sole and exclusive benefit of the person or entity who directly engaged BCH to prepare this report. Accordingly, this report is suitable only for such purpose, and is subject to any changes arising after the date of this report. This report is meant to be read as a whole, and accordingly no section or part of it should be read or relied upon out of context.

Unless otherwise expressly agreed by BCH:

- (a) any assumption, data or information (whether embodied in tangible or electronic form) supplied by, or gathered from, any source (including, without limitation, any consultant, contractor or subcontractor, testing laboratory and equipment suppliers, etc.) upon which BCH's opinion or conclusion as set out in this report is based (individually and collectively, "Information") has not been verified by BCH or BCH's Personnel; BCH makes no representation as to its accuracy or completeness and disclaims all liability with respect to the Information;
- (b) except as expressly set out in this report, all terms, conditions, warranties, representations and statements (whether express, implied, written, oral, collateral, statutory or otherwise) are excluded to the maximum extent permitted by law and, to the extent they cannot be excluded, BCH disclaims all liability in relation to them to the maximum extent permitted by law;
- (c) BCH does not represent or warrant the accuracy, completeness, merchantability, fitness for purpose or usefulness of this report, or any information contained in this report, for use or consideration by any person or entity. In addition, BCH does not accept any liability arising out of reliance by a person or entity on this report, or any information contained in this report, or for any errors or omissions in this report. Any use, reliance or publication by any person or entity of this report or any part of it is at their own risk; and
- (d) In no event will BCH or BCH's Personnel be liable to any recipient of this report for any damage, loss, cost, expense, injury or other liability that arises out of or in connection with this report including, without limitation, any indirect, special, incidental, punitive or consequential loss, liability or damage of any kind.

Copyright Notice

Copyright and all other intellectual property rights in, and to, this report are the property of, and are expressly reserved to, BCH. Without the prior written approval of BCH, no part of this report may be reproduced, used or distributed in any manner or form whatsoever.

Contributors

The following Professionals of Record (POR) accept responsibility for their technical content in the specified respective sections. Professionals apply their signature and/or seal for the technical or non-technical content as appropriate.

Section: Discipline:
The entire report Interconnection Planning
except those
listed below

Contributed by:

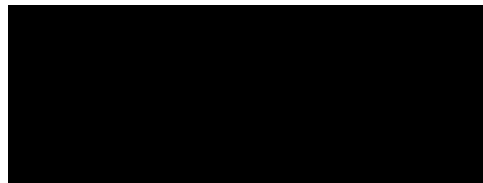

Specialist Engineer, Interconnection
Planning

For H

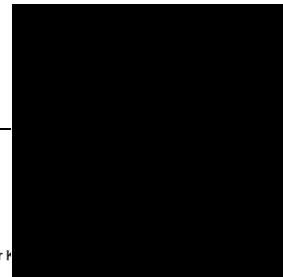

Section: Discipline:
5.7 Stations Planning

Contributed by:

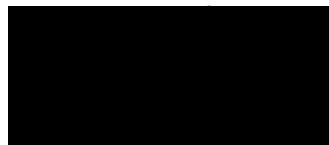

Specialist Engineer, Substations
Growth and Sustainment

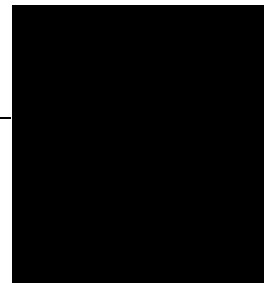

Section: Discipline:
5.8 Transmission Line Engineering

Contributed by:



Senior Engineer, Transmission Line
Engineering

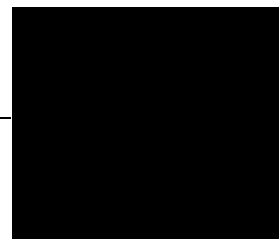

Section: Discipline:
5.9.1 Protection Planning

Contributed by:

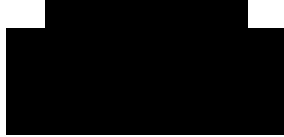

Specialist Engineer, Transmission P&C
Engineering



Section: Discipline:
5.9.2 Control Planning

Contributed by:

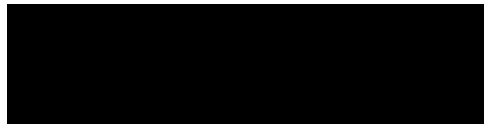

Specialist Engineer, Transmission P&C
Engineering

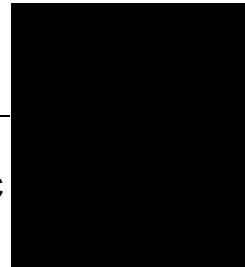

Section: Discipline:
5.6 Transmission Operations Services

Contributed by:



Specialist Engineer, Transmission
Operations Services



Section: Discipline:
5.4 Analytical Studies

Contributed by:

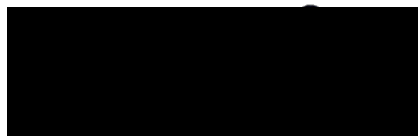

Team Lead, Substations Growth and
Sustainment

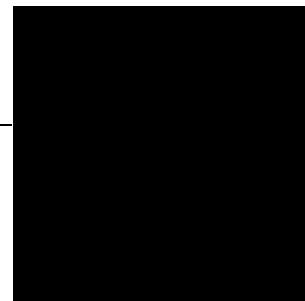

Section: Discipline:

5.9.3 Telecom Planning

Contributed by:



Specialist Engineer, Telecom Planning
& Asset Management

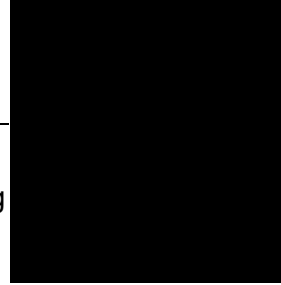

Section: Discipline:

7 Revenue Metering

Contributed by:

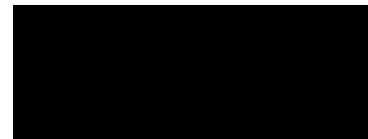

Senior Engineer, Revenue Metering

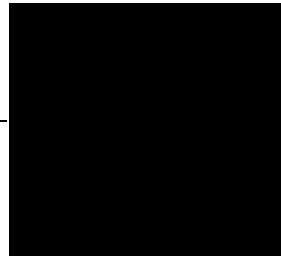

Table of Contents

Executive Summary	xiii
1 Introduction	1
2 Purpose of Study	4
3 Scopes of Study	5
4 Assumptions and Conditions	6
5 System Studies and Results	8
5.1 Steady-State Power Flow Study	8
5.2 Transient Stability Study	10
5.3 Reliability Impact to Adjacent Utilities	11
5.4 Analytical Studies	12
5.5 Short Circuit Analysis	13
5.6 Remedial Action Schemes	13
5.6.1 Regional System RAS Requirements	13
5.6.2 Bulk System RAS Requirements	14
5.7 Station Upgrade Requirements	14
5.8 Transmission Line Upgrade Requirements	15
5.9 Protection, Control and Telecommunications	17
5.9.1 Protection	17
5.9.2 Control	19
5.9.3 Telecommunications	21
6 Cost Estimate and Schedule	23
7 Revenue Metering	24
8 Conclusions	26

Tables

Table 1-1: Summary of Project Information	1
Table 5-1: Steady-State Performance Concerns and Solutions	9
Table B-1: Summary of Branch Loading Results in Base Scenario	30
Table B-2: Selected Bus Voltages for in Base Scenario	31
Table B-3: Summary of Branch Loading Analysis Results in Sensitivity Scenario (██████████) and WKTP Excluded)	31

Table B-4: Summary of Branch Loading Analysis Results in Sensitivity Scenario with a Lower Transfer on West of ACK/VAS Cut Plane	33
Table C-1: Transient Stability Study Results	34
Table D-1: Selected Model Parameters in WTG User-Defined Model ██████████	35
Table D-2: Selected Parameters in User-Defined Wind Park Controller Model ██████████	35
Table D-3: Selected Model Parameters in WTG User-Defined Model ██████████	36
Table D-4: Selected Parameters in User-Defined Wind Park Controller Model ██████████	36

Figures

Figure 1-1: Nicola-Highland Region Transmission System.	2
Figure A-1: Schematic Diagram of ██████████ Project and ██████████ Project	29
Figure E-1: Preliminary One-Line Sketch for the Proposed Switching Station KBTX at Stage 1	37
Figure E-2: Preliminary One-Line Sketch for the Proposed Switching Station KBTX at Stage 2	38
Figure F-1: Proposed POI Location Diagram	39
Figure F-2: Conceptual Ingress/Egress (In/Out) of Proposed Switching Station KBTX	39
Figure H-1: Telecom block diagram identified for ██████████ and ██████████	44

Appendices

Appendix A	Schematic Diagram of ██████████ Project and ██████████ Project
Appendix B	Power Flow Study Results
Appendix C	Transient Stability Study Results
Appendix D	IC Provided Power Flow and Dynamic Models and Data
Appendix E	Preliminary One-Line Sketch for Future Proposed Switching Station (KBTX)
Appendix F	Transmission Line Diagrams and Additional Information
Appendix G	Additional Protection Requirements

Appendix H	Telecom Requirements and Telecom Block Diagrams
Appendix I	Revenue Metering Related Telecommunications Requirements

Acronyms

The following are acronyms used in this report.

BCH	British Columbia Hydro and Power Authority
BDM	██████████ Substation
BEW	██████████ Step-up Substation
COD	Commercial Operation Date
CT	Current Transformer
DCP	Data Concentration Point
DFR	Digital Fault Recorder
DTT	Direct Transfer Trip
EMS	Energy management System
ERIS	Energy Resource Interconnection Service
FRP	Fibre Reinforced Polymer
FRT	Fault Ride-Through
FVO	Fraser Valley Office
HS	Heavy Summer Load Condition
HVC	██████████ Substation
HW	██████████ Project
HW	Heavy Winter Load Condition
IC	Interconnection Customer
IED	Intelligent Electronic Device
IP	Internet Protocol
IPO	Independent Pole Operated
ISD	In-Service Date
KBTX	Temporary Station Code for Proposed Switching Station on 1L244
KLY	Kelly Lake Substation
K2W	██████████ Step-up Substation
LS	Light Summer Load Condition

MC Measurement Canada or Canada Federal Regulations
MPO Maximum Power Output
NERC North American Electric Reliability Corporation
NIC Nicola Substation
NRIS Network Resource Interconnection Service
OOS Out of Service
PCO Planning Coordinator Office
PODR Point of Delivery Reference
POI Point of Interconnection
POM Point of Metering
PPC Power Plant Controller
PPIS Power Parameter Information System
RAS Remedial Action Scheme
RASRS WECC Remedial Action Scheme Reliability Subcommittee
SCADA Supervisory Control and Data Acquisition
SIO South Interior Office
SIS System Impact Study
TIR BC Hydro 60 kV to 500 kV Technical Interconnection requirements for
Power Generators
TOV Temporary Overvoltage
VT Voltage Transformer
WBK West Bank Substation
WECC Western Electricity Coordinating Council
WSN Williston Substation
WTG Wind Turbine Generator

Executive Summary

This report documents the Interconnection System Impact Study (SIS) results for the ██████████ Project and ██████████ Project, both of which are successful projects selected under the 2024 Call for Power. As both projects share a common Point of Interconnection (POI), they are studied as a cluster (referred to as “the subject cluster” hereafter). The project description is as follows.

██████████ **Project:** ██████████, an Interconnection Customer (IC), requests to connect its ██████████ Project into the BCH system. The project has ██████████ wind turbine generators with a total capacity of 159.6 MW. The proposed POI is located on BC Hydro’s existing 138 kV transmission line 1L244, approx. 32.4 km from Nicola Substation (NIC). This project will connect to the proposed POI via a 6.5 km transmission line, to be built by the customer, with a maximum power injection of approx. 155 MW at the POI. The project’s proposed commercial operation date (COD) is Oct 1, 2031.

██████████ **Project:** ██████████, the other Interconnection Customer (IC), requests to connect its ██████████ Project into the BCH system. The project has ██████████ wind turbine generators with a total capacity of 94.4 MW. ██████████ project shares the same POI as ██████████ project. It will connect to the proposed POI via a 10.4 km long transmission line, to be built by the customer, with a maximum power injection of approx. 91.25 MW at the POI. The project’s proposed COD is Sept 30, 2028.

The existing line 1L244 currently operates as a radial line and primarily supplies the West Bank substation (WBK). West Kelowna Transmission Project (WKTP) is a future transmission capital project in the study area, aimed at enhancing the reliability of power supply to WBK. The technically leading alternative of WKTP is to build a new 138 kV line from WBK to Fortis BC’s Recreation substation (REC), with a considered in-service date of November 2032. After the WKTP enters service, the line 1L244 will no longer operate as a radial line. This clustered SIS considers the operation of line 1L244 under pre- and post-WKTP scenarios.

To interconnect the subject cluster at the proposed POI, the SIS has identified the following conclusions and requirements.

1. Stage 1 — Interconnecting the [REDACTED] project (Proposed COD: Sept 30, 2028).
 - A new 138 kV switching station (temporarily referred to as “KBTX”) is required, on the BCH’s existing circuit 1L244 at or close to the proposed POI, for interconnecting the [REDACTED] project into the BCH system. See note 1 below.

Note 1: with the new switching station KBTX, 1L244 will be segregated into two new lines, temporarily referred to as 1L244_A (NIC-KBTX) and 1L244_B (KBTX-WBK). The 138 kV interconnection line for [REDACTED] project, to be built by the customer, is temporarily referred to as 1L244_C (BEW-KBTX). These temporary line designations will be replaced by permanent ones at a later stage of interconnection study.

- At Stage 1, the power injection from [REDACTED] project does not result in any performance concern in the regional system under system normal or applicable contingencies conditions.

2. Stage 2 — Interconnecting the [REDACTED] project (Proposed COD: Oct 1, 2031).

- The installation of additional station equipment at KBTX is required to accommodate the interconnection of [REDACTED] project. This includes additional circuit breakers, disconnect switches, line terminals, and other station equipment. See Note 2 and Note 3 below.

Note 2: for efficient project delivery, it is recommended to construct the proposed KBTX switching station as a full 4-CB switching station with 4-line terminals in one substation project, combining Stage 1 and Stage 2 station scopes. This approach is advised considering that [REDACTED] and [REDACTED] projects will be connected only three years apart.

Note 3: the 138 kV interconnection line for [REDACTED] project, to be built by the customer, is temporarily referred to as 1L244_D (K2W-KBTX).

- At Stage 2, with the power injection from both [REDACTED] and [REDACTED] projects at KBTX, line 1L244_A is subject to pre-contingency overloads during periods of high surplus generations. To address this overload, the recommended alternative is permanent relocation of line 1L244_A, i.e. to build a new 138 kV line from NIC to KBTX in parallel with the existing line 1L244 and replace the existing line section after the new line is operational.

- At Stage 2, line 1L244_A, after being permanently relocated, may still experience thermal overloads under contingencies. To address this concern, both ██████████ project and ██████████ project are required to participate in a generation runback remedial action scheme (RAS) based on local detection.
3. Stage 3: when WKTP enters service (Considered ISD: Nov 30, 2032).
 - After WKTP, line 1L244_B needs to accommodate additional flow to FBC via the new tie line. This flow pattern change could overload the line 1L244_B under infrequent system normal (N-0) conditions — specifically high wind generations coinciding with summer peak loads at WBK and high transfers on the new tie line. To prevent this overload, the new tie (WBK–REC) needs to remain open at the WBK end in these N-0 conditions; an overload detection on 1L244_B is required at WBK and it will trigger an alarm and trip the tie line if overload is detected under the closed-tie conditions.
 - At Stage 3, any protective or non-protective opening of 1L244_A could result in an instability concern attributed to the addition of the subject cluster. To address this concern, both ██████████ project and ██████████ ██████████ project are required to participate in a generation shedding RAS for these contingencies.
 4. For both ██████████ project and ██████████ project, voltage sags caused by energization of the substation main transformer exceed the limits specified in BC Hydro's TIR. Each IC is required to use point-on-wave (POW) controlled closing with independent pole operated (IPO) 138 kV circuit breakers for mitigating the transformer inrush current.
 5. The turbines at ██████████ project and ██████████ project are required to have fault ride-through (FRT) capabilities per BCH's TIR. Using the default settings provided, the fault ride-through performance of the inverters is satisfactory and does not result in unexpected tripping or momentary cessation in dynamic simulations. BC Hydro will follow up on the ride-through settings during the pre-commissioning stage.
 6. Both ██████████ project and ██████████ project are capable to meet its respective dynamic reactive power capability requirement specified in the BC Hydro's TIR Section 6.4.2 over most of the MW operating range (including full to lower MW output) and provide a partial reactive capability

at zero MW output provided that the turbine's "STATCOM" option is enabled. This "STATCOM" mode shall be made available to each of the wind turbines at the [REDACTED] project and at the [REDACTED] project.

7. BCH will provide line protections for 1L244_A, 1L244_B, 1L244_C (BC Hydro end only) and 1L244_D (BC Hydro end only). As part of the line protection replacements for each of the four lines, telecommunication facilities will be required to accommodate the new protection schemes. The IC of [REDACTED] and the IC of [REDACTED] shall provide required relays, telecom facility and associated equipment at its facilities to accommodate the new protection schemes.
8. Anti-islanding protection is required for both [REDACTED] project and [REDACTED] project and shall be configured in the manner that does not compromise the required ride-through performance.
9. A telecommunication-based anti-islanding Direct Transfer Trip (DTT) scheme is required in accordance with IEEE Std 2800-2022. This DTT scheme will initiate a trip to both [REDACTED] project and [REDACTED] project for any protection tripping or manual opening of the line section 1L244_A (NIC-KBTX) in the pre-WKTP scenario. After WKTP enters service, this DTT scheme requires revision to reflect the updated network configuration.
10. Virtual Inertia Control (VIC), a form of Fast Frequency Response (FFR), is required at both [REDACTED] project and [REDACTED] project. The proposed wind turbine generators (WTG), when equipped with the VIC function, are expected to temporarily boost the MW output to limit the system frequency drop during a major frequency event. The VIC settings should be determined in coordination with BC Hydro in the later stage of interconnection studies.

The above requirements and conclusions are made based on the IC's input data and study assumptions listed in Section 4, which represents the best available information for the study.

A non-binding good faith cost estimate and the estimated schedule of the Network Upgrades identified for the project interconnection are provided in a letter that accompanies this report. The identified Network Upgrades refer to the additions and modifications to the BC Hydro owned transmission facilities for interconnecting the proposed project.

1 Introduction

This report documents the Interconnection System Impact Study (SIS) results for the ██████████ Project and ██████████ Project, both of which are successful projects selected under the 2024 Call for Power. As both projects share a common Point of Interconnection (POI), they are studied as a cluster (referred to as “the subject cluster” hereafter). The project description is as follows.

██████████ project: ██████████, the interconnection customer (IC), requests to interconnect its ██████████ Project to the BC Hydro system. ██████████ Project has ██████████ wind turbine generators with a total capacity of 159.6 MW. This customer’s step-up substation is designated as “K2W”, which will connect to the BCH’s system through a customer-built 138 kV, 6.5 km line. The maximum power injection at the proposed POI is 155 MW. The proposed commercial operation date (COD) is Oct 1, 2031.

██████████ project: ██████████, the other interconnection customer, requests to interconnect its ██████████ Project to the BC Hydro system. The project has ██████████ wind turbine generators with a total capacity of 94.4 MW. This customer’s step-up substation is designated as “BEW”, which will connect to the BCH’s system through a customer-built 138 kV, 10.4 km line. The maximum power injection at the proposed POI is 91.25 MW. The proposed COD is Sept 30, 2028.

██████████ Project and ██████████ Project will connect to the BC Hydro system at the same proposed POI, which is located on BC Hydro’s existing 138 kV transmission line 1L244, approximately 32.4 km from Nicola Substation (NIC). The project overview is provided in Table 1-1.

Table 1-1: Summary of Project Information

Project Name	██████████ Project		██████████ Project	
Name of Interconnection Customer (IC)	██████████			
IC Proposed Point of Interconnection	A point on 1L244, 32.4 km from NIC		A point on 1L244, 32.4 km from NIC	
IC Proposed COD	September 30, 2031		September 30, 2028	
Type of Interconnection Service	NRIS <input checked="" type="checkbox"/>	ERIS <input type="checkbox"/>	NRIS <input checked="" type="checkbox"/>	ERIS <input type="checkbox"/>
Maximum Power Injection (MW) at POI	155 (Summer)	155 (Winter)	91.25 (Summer)	91.25 (Winter)
Number of Generator Units	██████████			
Plant Fuel	Wind		Wind	

West Kelowna Transmission Project (WKTP) is a major transmission capital project being planned in the study area. At this time, the leading alternative for WKTP is Alternative 3E, which will build a new 138 kV line from WBK to Fortis BC's Recreation substation (REC). The considered in-service date of the WKTP is November 2032.

Appendix A shows the plant-level schematic diagram of the ██████████ Project and ██████████ Project.

2 Purpose of Study

The purpose of this System Impact Study (SIS) is to assess the impact to the BC Hydro transmission system of interconnecting the proposed Customer's facility, in accordance with the relevant BCH Open Access Transmission Tariff (OATT).

This study aims to identify transmission constraints and determine system reinforcement options, including the implementation of a Remedial Action Scheme (RAS) for generation shedding or generation runback, to ensure adequate performance and the reliable operation of the BC Hydro transmission system.

The SIS is performed in accordance with the North American Electric Reliability Corporation (NERC) reliability standards, Western Electricity Coordinating Council (WECC) performance criterion, and BC Hydro transmission planning requirements, specifically:

- NERC standards: FAC-002-3, TPL-001-4;
- WECC Performance Criterion: TPL-001-WECC-CRT-4;
- BC Hydro's 60 kV to 500 kV Technical Interconnection Requirements for Power Generators (hereafter referred to as "TIR") per NERC Standard FAC-001-3; and
- BC Hydro's Transmission Asset Planning FAC-002-3 Study Guide.

3 Scopes of Study

This study investigates potential thermal overloading, voltage performance and stability constraints of the transmission system as a result of the proposed interconnection and identifies the requirements of the Network Upgrades in the BC Hydro transmission system to accommodate the IC's proposed interconnection.

This study is based on available information provided by the IC. Further studies or a study update may be required when additional data from the IC is available or key study assumptions are updated.

This study does not address the possible impact of the proposed interconnection on the adjacent systems that are neighboring with the BCH system. BC Hydro coordinates and cooperates with the neighboring systems per FAC-002-3 for them to assess the potential impact on the adjacent systems when needed.

4 Assumptions and Conditions

This SIS is performed based on the information in the IC's interconnection data form submitted on Jun 27, 2025 (final submission date for [REDACTED]) and Jun 5, 2025 (final submission date for [REDACTED]).

The study assumptions and conditions used in the study cases include the forecasted load levels, generation resource plans, and facility ratings, etc. for the selected study years as appropriate. The key assumptions and study conditions used in this SIS are listed below:

- The 2032 Heavy Winter (HW) and 2033 Heavy/Light Summer (HS/LS) study cases, representative of post-WKTP scenario (i.e. base scenario), are selected to study the proposed interconnection of the subject generating project. In addition, other planning cases are considered to account for additional scenarios (e.g. pre-WKTP scenario).
- The generation dispatch in the study model represents both existing and future generators in BC Hydro's Base Resource Plan (BRP) that was available to start the SIS. Specifically, the 2024 power call projects relevant to the proposed interconnection are included in the study model.
- Similarly, the forecasted loads in the study model represent the existing and future loads that were available at the time of preparing the SIS.
- The facility ratings used in this study are based on BC Hydro operating order 5T-10 dated May 12, 2025, and 5T-14 dated Dec 18, 2024.
- The regional generation are dispatched to the patterns that stress the transmission system in the study area. In these patterns, the regional generations are typically set to their Maximum Power Outputs (MPO) unless otherwise specified.
- The West Kelowna Transmission Project (WKTP) Alternative 3E¹ is included in the study model. WKTP will build a new 138 kV line from BC Hydro's West Bank substation (WBK) to Fortis BC's Recreation substation (REC) is included in the study model. The considered in-service date for WKTP is November 2032.
- Nicola Substation Transformation Capacity Reinforcement project will add a new 230/138 kV transformer at NIC (i.e. NIC T7) to mitigate the possible

¹ BC Hydro, West Kelowna Transmission Project, see details in <https://www.bchydro.com/energy-in-bc/projects/wktp.html>

transformer overload associated with the industrial load increase in the Highland region.

- The description of upgrade scopes in this SIS report is split into the following three stages. The staging is based on the anticipated sequence of the project in-service dates and may be subject to change.
 - Stage 1: when ██████████ project enters service (Proposed COD: Sept 2028).
 - Stage 2: when ██████████ project enters service (Proposed COD: Oct 2031).
 - Stage 3: when WKTP project enters service (Considered ISD: Nov 2032).

5 System Studies and Results

Based upon the IC's submitted information and the area system conditions, a new switching station (referred to as "KBTX") at or close to the proposed POI on the existing line 1L244 is required to interconnect the [REDACTED] and [REDACTED] cluster to the BCH system. The addition of the new switching station would help to maintain reliability and adequate protection performance to serve the existing customers and the new project addition.

Note that with the new switching station KBTX, 1L244 will be segregated into two new lines, temporarily referred to as 1L244_A (NIC-KBTX) and 1L244_B (KBTX-WBK). The 138 kV interconnection line for [REDACTED] project, to be built by the customer, is temporarily referred to as 1L244_C (BEW-KBTX); and the one for [REDACTED] project is referred to as 1L244_D (K2W-KBTX). These temporary line designations will be replaced by permanent ones at a later stage of interconnection study.

5.1 Steady-State Power Flow Study

A series of pre- and post-contingency power flow analyses were performed to assess the impact of the subject project on the regional transmission system. The study was performed for the study cases based on the assumptions and considerations outlined in Section 4.

The power flow study focuses on the base scenario that is representative of the following study conditions.

- 2032 HW, 2033 HS and 2033 LS load conditions.
- The subject cluster along with the other three 2024 power call projects in the South Interior West region (i.e. HVW, MMW and SHQ) are included in the study model.
- WKTP (Alternative 3E) is included in the study model.
- A higher Columbia generation and a lower Peace generation pattern – with a high transfer on 500 kV lines 5L76, 5L79 and 5L98, collectively referred to as the “west of ACK/VAS cut plane”.

In addition to the base scenario, additional study scenarios have been assessed, focusing on the following variables:

- Period during which only [REDACTED] project is operational (i.e. 2028–2031).
- 1L244 operations in pre- and post-WKTP configurations.

- Flow pattern on the 500 kV lines 5L76, 5L79 and 5L98, which are operated in parallel with the future WBK-REC tie line to be established with WKTP.
- Extreme heat conditions (35°C ambient or above).

Table 5-1 shows a summary of steady-state performance concerns and solutions identified in the SIS. Appendix B contains the details of power flow study results.

Table 5-1: Steady-State Performance Concerns and Solutions

Equipment subject to overloads	Conditions observed	Contingencies that result in overloads (Examples)	Solution Proposed
Under system normal conditions			
1L244_A	LS	P0: system normal	Uprate line 1L244_A to achieve a continuous rating of 961 A or greater at 30°C ambient.
1L244_B	HS (Note 1)	P0: system normal	An overload detection on 1L244_B at WBK that will alarm and trip the WBK-REC tie. (see Note 2)
Under contingencies			
1L244_A	LS, HS, HW	P1.2: 1L244_B, 5L98 P1.3: WBK T1 P2.1: Open 1L244_B at WBK with no fault	Generation Runback RAS at ██████████ and ██████████ (see Section 5.6)
1L244_B	LS, HS, HW	P1.2: 1L244_A	Generation Runback RAS at ██████████ and ██████████ (see Section 5.6)
Future tie line (WBK-REC)	LS, HW	P1.2: 1L244_A	Generation Runback RAS at ██████████ and ██████████ (see Section 5.6)
<p>Note 1: this pre-contingency overload on 1L244_B occurs only with closed tie configuration — specifically when high wind generations coincide with both summer peak loads at WBK and high transfers on the WBK-REC tie.</p> <p>Note 2: once the WBK-REC tie line is tripped open, it may need to remain temporarily open until the system becomes suitable for closed-tie operation.</p>			

The key findings in the power flow study are summarized as follows.

- 1) Under system normal (N-0) condition, there is a new overload on line 1L244_A under light summer load condition, which are attributed to additions of ██████████ project and ██████████ project. To address the overload, the line 1L244_A from NIC to KBTX (approx. 32.4 km in length) shall be uprated to or replaced by a new line section with a summer

continuous rating of 961 A or greater at 30°C ambient.

- 2) The lines 1L244_A, 1L244_B and the future BCH-FBC tie line (WBK–REC) could be overloaded under various contingencies. These overloads will be addressed by generation runback remedial action schemes (RAS) as detailed in Section 5.6.
- 3) Upon completion of WKTP, line 1L244 will not only serve the WBK load but also accommodate additional power flows into the FBC system via the new WBK-REC tie line. This flow pattern change will increase the flow on 1L244_B and reduce the flow on 1L244_A during periods of high generation outputs from the wind farms, leading to the following concerns and mitigation measures.
 - Concern: the line 1L244_B could be overloaded under infrequent, scenario-specific N-0 conditions — specifically high wind generations coinciding with both summer peak loads at WBK and high transfers on the WBK–REC tie.
 - Mitigation measures: to prevent this overload, the WBK–REC tie needs to remain open at WBK end under the infrequent N-0 conditions mentioned above; an overload detection on 1L244_B is required at WBK (see Section 5.6) and it will trigger an alarm and trip the tie line if overload is detected under the closed-tie conditions. The exact conditions to open the tie line will be determined in future operational studies.

The BCH TIR requires Inverter Based Resource (IBR) power plant to have the dynamic reactive power capability at a minimum of +/- 33% of its MPO from the plant at the high-voltage side of the switchyard over the full MW operating range. The simulation results indicate that both [REDACTED] project and [REDACTED] project are capable of meeting their respective reactive capability requirements over most of the MW operating range (including full to lower MW output) — and also provide partial reactive capability at zero MW output provided that the turbine’s “STATCOM” option is enabled. This “STATCOM” mode shall be made available to all the WTGs at the [REDACTED] project and those at the [REDACTED] project.

5.2 Transient Stability Study

Transient stability studies have been performed to assess the impact of adding the subject cluster ([REDACTED] plus [REDACTED]) along with other successful 2024 Call for Power projects in the vicinity area, in accordance with the TPL-001-WECC-CRT-4 Performance Criteria. The dynamic simulation was performed using the 2033 light summer base case.

Appendix C shows a summary of transient stability results for 2033 light summer load conditions with both ██████████ and ██████████ projects dispatched to their maximum power outputs with WKTP in service.

The study found that, in the post-WKTP scenario, instability would occur for protective and non-protective opening of 1L244_A. The loss of 1L244_A would result in a low short-circuit ratio ($SCR < 2$) at the shared POI for the subject cluster, ending up with unstable generator outputs. Further study indicates that the system performance would become stable if ██████████ and ██████████ are isolated from the grid within certain time frame after fault initiation.

For both ██████████ project and ██████████ project, each IC is required to install anti-islanding protection within their facility to disconnect the wind farm from the grid when an inadvertent island with the local load forms. This anti-islanding protection (e.g. often implemented as power quality protection) shall be configured in the manner that does not compromise the required ride-through performance.

Besides, upon the both IC's submissions, the WTGs at ██████████ project and those at ██████████ project can provide Fast Frequency Response (FFR) if the turbine's Virtual Inertia Control (VIC) function is enabled. The VIC function is required at both ██████████ project and ██████████ project to limit the system frequency drop during a major frequency event. The VIC settings should be determined in coordination with BC Hydro in the later stage of interconnection studies.

5.3 Reliability Impact to Adjacent Utilities

The study has considered the reliability impact of the proposed interconnection to adjacent systems (i.e. specifically the Fortis BC system).

According to FAC-002-3 Part 1.4, facility interconnection results shall be evaluated and coordinated by entities involved. This Mandatory Reliability Standard (MRS) requirement is met with the following arrangement.

- 1) The connection of ██████████ and ██████████ projects is not expected to impact the FBC system until WKTP enters service.
- 2) The BC Hydro Planning Coordinator Office (PCO) has shared with Fortis BC the preliminary study findings (i.e. a short summary of power flow analysis results in Table 5.1) in a memo letter dated June 30, 2025. The shared information serves as an input to facilitate the FBC's updated WKTP planning study.
- 3) BC Hydro will work with Fortis BC to coordinate the connection of the

future tie line and jointly identify network upgrade solutions that incorporate the effect of [REDACTED] and [REDACTED] projects.

5.4 Analytical Studies

Analytical Studies identified the following key findings and recommendations:

- 1) The risk of temporary over-voltages (TOVs) was assessed under the unintentional islanding contingency. Islanding occurs when [REDACTED] and [REDACTED] and possibly a portion of the area loads become isolated from the main grid but remain energized. Based on the analysis, no risk of TOVs was identified.
- 2) Anti-islanding protection is required for both the [REDACTED] Project and [REDACTED] Project. A telecommunication-based Direct Transfer Trip (DTT) scheme is required in accordance with IEEE Std 2800-2022. This DTT scheme will initiate a trip to isolate both the [REDACTED] and [REDACTED] from the BCH system for any protection tripping or manual opening of 1L244_A in the pre-WKTP scenario. After WKTP enters service, this DTT scheme would need a revision to reflect the updated network configuration.
- 3) Voltage disturbance resulting from energization of a main power transformer was studied under system normal and contingency conditions. The voltage sags exceeded the limit specified in BC Hydro's TIR. Both the [REDACTED] and [REDACTED] are required to mitigate the transformer inrush current using point-on-wave (POW) controller with independent pole operated (IPO) circuit breakers.
- 4) The harmonic current injection from the [REDACTED] and [REDACTED] shall not exceed the limit specified in TIR, which follows IEEE Std 519-2022. Harmonic studies will be conducted at a later stage when the spectrum of harmonic current injection from the WTGs becomes available.
- 5) Electromagnetic Transient (EMT) model is parameterized with the voltage and frequency ride-through settings that meets the TIR requirements. BC hydro will follow up on this topic during the pre-commissioning stage.
- 6) The electromagnetic transient responses of the [REDACTED] and [REDACTED] projects, including the active power control, reactive power control, and dynamic active power support under abnormal frequency conditions, are consistent with the facility's electrical and

control design specifications.

5.5 Short Circuit Analysis

The short circuit analysis for the System Impact Study is based upon the latest BC Hydro system model, which includes project equipment and impedances provided by the IC. Thevenin impedances for the near-term system conditions and the ultimate fault levels at POI are not included in this report but will be made available to the IC upon request.

5.6 Remedial Action Schemes

The following RAS requirements have been identified for interconnecting the subject cluster.

5.6.1 Regional System RAS Requirements

Stage 1

No regional system RAS requirement is identified at Stage 1.

Stage 2

At Stage 2, a response-based RAS with thermal overload detection of 1L244_A at KBTX is required to address the post-contingency overloads on 1L244_A as shown in Table 5.1. The RAS action is to run back and to a pre-determined level.

Stage 3

At Stage 3, a new tie line from WBK to REC is established, introducing additional performance concerns associated with the subject cluster. The RAS functions for regional system contingencies at Stage 3 are required based on the following considerations.

- Retain the thermal overload detection of 1L244_A at KBTX as well as all the logic functions implemented in Stage 2. This is to address thermal overload of 1L244_A for contingencies including protective or non-protective opening of 1L244_B.
- To address the pre-contingency overload on line 1L244_B as described in Section 5.1, implement an overload detection at WBK that will alarm and trip the tie line.
- Section 5.1 indicates that protective or non-protective open of 1L244_A results in transient stability issues due to low post-contingency SCR at the

shared POI. To address this issue, DTT to both [REDACTED] and [REDACTED] by tripping the respective interconnection tie lines is required.

- For scheduled outage of 1L244_A, a pre-outage operation instruction would need to be determined in the later stages based on further analytical studies to determine if [REDACTED] and [REDACTED] can be allowed to re-connect to the system for stable operation during 1L244_A out-of-service.

In addition, BC Hydro has planned a future EMS-based RAS function for the connection of WKTP, which will trip the existing line 1L244 at NIC for certain 500 kV contingencies. This RAS function must be modified to trip 1L244_B at KBTX to accommodate the integration of the subject cluster.

5.6.2 Bulk System RAS Requirements

The integration of both [REDACTED] Project and [REDACTED] project are required to implement runback schemes via the Energy Management System (EMS) based RAS to address increased generation injections during certain 500 kV contingency events.

5.7 Station Upgrade Requirements

The station upgrade requirement for the proposed switching station (KBTX) and at Nicola Substation (NIC) are described as follows:

Stage 1

With [REDACTED] project entering service, the following station upgrade work is required.

- Acquire adequate property for a new [REDACTED] & [REDACTED] Terminal station (KBTX) close to the existing transmission line 1L244. The property shall be chosen considering ultimate stage of the KBTX switching station.
- Construct a new outdoor 138kV, 3-circuit breaker ring bus switching station. Three circuit breakers (1CB1, 1CB2, and 1CB3) and associated disconnects shall be rated at 3000A.
- Install three 138 kV line terminals associated motorized disconnects, surge arresters and capacitor voltage transformers for the transmission lines 1L244_A, 1L244_B, and 1L244C (these lines designations shall be finalized at later stage).
- Install two single phase 138 kV station service VTs, 1SSVT1 and 1SSVT2.
- Install one set of diesel generator for station service backup.
- Construct a new control building and other required substation structure.

- Install associated station service, P&C, telecom, SCADA, and mechanical equipment including fire detection/extinguishing devices.
- Install station ground system.
- Install other necessary equipment and facilities required for new KBTX switching station.
- Please refer to Appendix E (see Figure E-1) for the preliminary one-line sketch for detailed work scope at Stage 1. This one-line sketch might be adjusted based on the size and orientation of the acquired property.

Stage 2

With ██████████ project entering service, the following station upgrade work is required.

- Add a 138 kV circuit breaker 1CB4 and associated disconnects. The circuit breaker and associated disconnects shall be rated at 3000 A.
- Install one 138 kV line terminal associated motorized disconnect, surge arresters and capacitor voltage Transformers for the transmission line 1L244D (the line designation shall be finalized at later stage).
- Install associated station service, P&C, telecom, SCADA.
- Please refer to Appendix E (see Figure E-2) for the preliminary one-line sketch for detailed work scope at Stage 2. This one-line sketch might be adjusted based on the size and orientation of the acquired property.
- To thermally upgrade 1L244_A as per requirement in section 5.1, 1L244 line jumpers at NIC shall be replaced with 2000 A rating conductors.

Note: for efficient project delivery, it is recommended to construct the proposed switching station (KBTX) to a full 4-CB ring bus switching station with 4-line terminals in one substation project. This approach is advised considering that ██████████ and ██████████ will be interconnected only three years apart.

Stage 3

No stations upgrade requirement is identified at Stage 3.

5.8 Transmission Line Upgrade Requirements

The Transmission Line Engineering's scope of work for the ██████████ and ██████████ cluster interconnection is described as follows.

Stage 1

At Stage 1, with ██████████ entering service, the 1L244 ingress/egress at KBTX is required, involving the following scope.

- Re-terminate line 1L244 approximately at Str 19-06 (adjacent to the proposed POI) to the new switching station KBTX. This will form a new section designated as 1L244_A from NIC substation to KBTX switching station. Depending on the location of the KBTX switching station, up to three 138kV 3-pole dead-end structures are required for this portion of the re-termination. (See diagrams in Appendix F for details)
 - This termination shall be built to achieve a continuous rating of 961 A or more at 30°C ambient with ASC conductor Bluebell or ACSR conductor Crane or equivalent.
- Re-terminate the other portion of line 1L244 approximately at structure 19-07 (adjacent to the proposed POI) with HAWK ACSR conductor to the new switching station KBTX. This will form a new section designated as 1L244_B from KBTX switching station to WBK substation. Depending on the location of the KBTX switching station, up to three 138kV 3-pole dead-end structures are required for this portion of the re-termination. (See diagrams in Appendix F for details)
- Undercrossing of 5L098 may be required to form the ingress and egress of 1L244 to KBTX.
- Additional right of way may be required to accommodate the ingress and egress of the line.
- Some portion of the existing line may need to be decommissioned which will involve removing some conductor, hardware, and existing structure.

Stage 2

At Stage 2, with [REDACTED] entering service (Proposed COD: 2031), thermal uprating of 1L244_A is required as per Section 5.1. The recommended alternative for thermal uprating is permanent relocation of 1L244_A (from NIC to KBTX) — to build a new 138 kV line from NIC to KBTX in parallel with the existing line 1L244 and replace the existing line section after the new line is operational. Appendix F contains additional information about the recommended alternative including background, other alternatives considered and technical rationales.

With the recommended alternative, a new 138kV wood or Fibre Reinforced Polymer (FRP) pole line is to be constructed parallel to 1L244 on the northeast side consisting of the following:

- 130EA tangent/ light angle H-frames.
- 30EA 3-pole dead-ends.
- 5EA medium angles.
- A total of 140 km of ASC conductor Bluebell or ACSR conductor Crane (1151 A or 1054 A @ 90°C, exceeding the required 961 A).

- The proposed poles are assumed to be mostly BCH standard 65' class 1 wood pole or equivalent.
- Select areas may require FRP poles due to wildfires and woodpeckers.

Note 1: 1L244 operates as normal during the construction of the new 138kV line. The existing 1L244_A is to be decommissioned after the successful connection of the new line.

Note 2: Additional right of way is required for the new line.

Stage 3

No transmission line requirement is identified at Stage 3.

Other Transmission Line Requirements

Additionally, the following requirements are identified on the Last Span on the customer's interconnection line to KBTX switching station.

- A dead-end structure should be installed as a demarcation point between Customer owned 138kV line 1L244_C and 1L244_D and BC Hydro owned portion of the line. BC Hydro will design and build the last span into the NETX substation.
- If the customer would like to design and build the last span from the customer line to KBTX switching station, BC Hydro will be performing the OE review for this design.

5.9 Protection, Control and Telecommunications

5.9.1 Protection

Stage 1

At Stage 1, with ██████████ entering service, BC Hydro will provide line protections for 1L244_A, 1L244_B and 1L244_C protections and associated RAS at NIC and KBTX Substations.

The IC of ██████████ is required to provide the following for the interconnection of its proposed wind farm at Stage 1.

- 1) Entrance protection that complies with the latest version of the BCH TIR.
- 2) Provide two SEL-411L-1 relays (firmware and options specified by BC Hydro) at the entrance of BEW to provide protection coverage for 1L244_C. BC Hydro P&C Planning will provide core protection settings for these relays to protect transmission line 1L244_C during a transmission line fault. Non-core protection such as local breaker failure,

auto-reclosing, backup protection for station elements will not be provided by BC Hydro P&C Planning.

- 3) The IC is responsible for NERC PRC-related tasks, settings to compliance standards within their facilities.
- 4) Provide anti-islanding protection as per Section 5.2, which can be implemented with a power quality (PQ) protection-based scheme.
- 5) Provide facilities and implement the 5L81/5L82/5L83 contingency runback at [REDACTED] in accordance with BC Hydro RAS requirements in Section 5.6.

Appendix G shows additional Stage 1 protection requirements applicable to the IC of [REDACTED] and protection modifications to the existing PSW wind farm.

Stage 2

At Stage 2, with [REDACTED] entering service, a new line 1L244_D (KTBX to K2W) will be built to interconnect [REDACTED]. BC Hydro will provide line protections for 1L244_D protections at KBTX substation and associated RAS at NIC and KBTX Substations.

The IC of [REDACTED] is required to provide the following for the interconnection of its proposed wind farm at Stage 2.

- 1) Entrance protection that complies with the latest version of the BCH TIR.
- 2) Provide two SEL-411L-1 relays (firmware and options specified by BC Hydro) at the entrance of K2W to provide protection coverage for 1L244_D. BC Hydro P&C Planning will provide core protection settings for these relays to protect transmission line 1L244_D during a transmission line fault. Non-core protection such as local breaker failure, auto-reclosing, backup protection for station elements will not be provided by BC Hydro P&C Planning.
- 3) The IC of [REDACTED] is responsible for NERC PRC-related tasks, settings to compliance standards within their facilities.
- 4) Provide anti-islanding protection as per Section 5.2 which can be implemented with a power quality (PQ) protection-based scheme.
- 5) Provide facilities and implement the 5L81/5L82/5L83 contingency runback for the [REDACTED] Farm in accordance with BC Hydro RAS requirements.
- 6) Provide facilities and implement 1L244_A overload runback at [REDACTED] farm in accordance with BC Hydro RAS requirements in Section 5.6.

The IC of [REDACTED] is required to provide the following to accommodate the interconnection of [REDACTED] farm at Stage 2:

- Provide facilities and implement 1L244_A overload runback for the ██████████ Farm in accordance with BC Hydro RAS requirements.
- Modify BEW protection settings, as needed, to accommodate the interconnection of ██████████ farm.

Appendix G shows additional Stage 2 Protection requirements applicable to the IC of ██████████ and protection modifications to the existing PSW wind farm.

Stage 3

At Stage 3, with WKTP entering service, a new tie line from WBK to REC will be established. The following P&C work at Stage 3 is identified to address the corresponding RAS requirements stated in Section 5.6.

- BC Hydro will modify KBTX 1L244_A protections for the 1L244_A protective or non-protective open RAS contingency and tripping of KBTX 1L244_C and KBTX 1L244_D.
- BC Hydro will modify WBK 1L244_B protections for the 1L244_B overload contingency and automatic opening of WKTP tie line at WBK. Detail of the overload protection will be determined later.
- BC Hydro will implement DTT from NIC to KTBX 1L244_B for 5L76 and 5L79 contingency.

Note that all the other WKTP protection work (i.e. protection system modification and setting review of BC Hydro system and associated wind generating stations) will be addressed separately in the WKTP project.

5.9.2 Control

Stage 1

The IC of ██████████ is required to provide the following in Stage 1.

- a) The IC will provide SCADA data reporting to the control centers in accordance with the TIR, including required telemetry, meteorological data, and status information, which should be available to the Energy Management System (EMS) at the nearest suitable BC Hydro site with appropriate telecom facilities. This data will be supplied to BC Hydro Control Centers in DNP 3.0 format. All data provided in response to poll messages transmitted by BC Hydro must be completed in less than or equal to 2 seconds.
- b) The IC's telemetry and status will be routed to the appropriate Data Collection Platform (FVO/SIO DCP) sites. BC Hydro control centers are required to reconfigure the existing equipment to accommodate

- the new wind farms, include the generator into the network model, and add the new telemetry and alarm points.
- c) The IC is responsible for providing appropriate PPIS meters per the TIR requirements, connected to a suitable high voltage source for harmonics and power quality metering.
 - d) The IC is responsible for providing communications links for remote interrogation of the line protection relays, revenue meters and PPIS equipment by BCH servers. The relay interrogation functionality should be provided by an SEL-3622 or equivalent.
 - e) The communication alternatives available to BC Hydro interconnection customers depending on the type and capacity of the interconnection. Communications and equipment selection² is subject to BCH review and approval.
 - f) Implement the 5L81/5L82/5L83 contingency runback for the [REDACTED] Farm in accordance with Section 5.9.1. The customer must coordinate with the BCH RASRS representative to ensure the data provided and associated schedule will allow BCH to obtain RAS approval on time.

BC Hydro is required to perform the following control work in Stage 1.

- Some work will be required by BC Hydro to update and recommission telemetry, alarms, and remote access at NIC, WBK and PSW with the revised or new protection relays or RAS or DTT devices.
- RAS related Telecom and Control work are also required at NIC and KBTX substations.
- The new KBTX switching station shall receive a full new control system as part of this project.
- BC Hydro control center to add KBTX in the EMS network model, and update EMS database and displays at FVO/SIO to reflect the control, indication, telemetry, RAS, and alarm addition/revision at KBTX, NIC, PSW and WBK.

Stage 2

The IC of [REDACTED] is required to provide the following in Stage 2.

- Apply the same requirements listed in item (a) through item (f) in Section 5.9.2 subheading “Stage 1”.

BC Hydro is required to do the following control work in Stage 2.

² Refer to P&C / Telecom Solution Guide for BC Hydro and Interconnection Customers (ES 46-J0137 R0), Section 4.2 “Communication Alternatives Selection Table” to identify acceptable communication solution candidates for Plants rated >75MVA.

- Some control work will be required by BC Hydro to update and recommission telemetry, alarms, and remote access at NIC, WBK and PSW with the revised or new protection relays or RAS IEDs or DTT circuits. Control systems at KBTX station will be updated to accommodate new K2W associated equipment.
- BC Hydro control center to update EMS database and displays at FVO/SIO to reflect the control, indication, telemetry, and alarm addition/revision at KBTX, NIC, PSW and WBK.

Stage 3

BC Hydro is required to provide the following control work in Stage 3.

- Minor control work will be required by BC Hydro to update or add alarms and telemetry at NIC, WBK and KBTX with the revised or new protection relays or RAS IED or DTT circuits.
- BC Hydro Control Centre to update EMS database and displays at FVO/SIO to reflect the alarm or RAS addition/revision at NIC, KBTX, and WBK as required.

Note that the control work under subheading “Stage 3” addresses only the control requirements from Protection (Section 5.9.1). All the other Stage 3 control work will be addressed separately in the WKTP project.

5.9.3 Telecommunications

A telecom solution has been identified to meet the requirements for teleprotection, telecontrol, RAS and other network additions (see these requirements in Appendix H). The detailed telecom work scopes and specs will be provided in detail at a later stage of Interconnection Studies.

IC of ██████████ Work Required at BEW

- Install and terminate two fibre optic cables; construct a diverse-route facility to support WECC Level 1 circuits; install a 48V DC power system with 8 hours reserve and a dual shelf 7705 SAR-8 router; implement various telecom circuits for teleprotection, SCADA, RAS, PPIS and revenue metering.

IC of ██████████ Work Required at K2W

- Same as those required at BEW (see above).

BCH’s Work Required at KBTX

- Install tower, two waveguides, and antenna facing HAM; Install five racks, dehydrator, fibre patch panel, dual shelf frequency-diversity microwave terminal, and other telecom equipment. Implement various telecom circuits.

The Telecom solution is developed based on the assumption as follows.

- a) Additional works in this area are anticipated to proceed under the [REDACTED], [REDACTED], and [REDACTED] interconnection projects.
- b) It is assumed that a sufficiently tall tower would be employed at KBTX to reach HAM and that the location of KBTX would be in accordance with Assumption 4.
- c) The location selected for KBTX would be in the vicinity of either: 49° 55' 30.52" N and 120° 8' 36.3" W, or 49° 56' 17.78" N and 120° 10' 41.2" W.
- d) BCH would perform a microwave link interference analysis through FCSA for the HAM-KBTX, and HAM-NIC microwave radio links. Upon success of the interference analysis and upon receipt of required environmental information and other consultation related to new towers and antennas, BCH telecom Engineering would apply for radio licensing through ISED Canada.
- e) Assume good cellular data or satellite coverage is available at both K2W and BEW enabling these customers to furnish Revenue Metering and PPIS circuits.
- f) At HAM, it is assumed that there is no tower capacity available for antenna additions and that a new tower could be added near the existing tower.

6 Cost Estimate and Schedule

A non-binding good faith cost estimate and the estimated schedule of the Network Upgrades identified for the project interconnection are provided in a letter that accompanies this report. The identified Network Upgrades refer to the additions and modifications to the BC Hydro owned transmission facilities for interconnecting the proposed project.

7 Revenue Metering

The following Revenue Metering requirements apply to both [REDACTED] and [REDACTED] projects.

- The remote read load profile revenue metering installation should be in accordance with Canada federal regulations (MC) and BC Hydro Requirements for Complex Revenue Metering. The latest version of this document is published at BC Hydro's external website. The revenue metering responsibilities and charges shall be in accordance with Section 10 (10.1 and 10.2). For details about the specific responsibilities, see table on pages.23-25.
- Primary Metering is required; 3-element metering scheme with 3 CTs and 3 VTs connected L-N (Grd) should be used.
- Main and backup load profile interval meters are required to measure the power delivered. The meters will be programmed for 5 minutes interval and will be remotely read each day by BCH Billing Group using MV-90 System; the POM shall have a dedicated communications link (BC Hydro's approved wireless IP solutions, landline or other approved alternative). The communications link should be used for revenue metering only. If there is IP digital cell phone coverage for data in the site, BCH can supply an IP Wireless Communications Modem equipment. BCH Transmission P&C Telecom/P&C Engineering Department should inform the connectivity options for complex metering at this specific site.
- The revenue class meters (main and backup) are Measurement Canada (MC) approved and will be supplied and maintained by BC Hydro. The MC approved revenue class instrument transformers (CTs and VTs units) are supplied by BCH (Stock items w/CAT ID).
- When the impedance and losses between the POM and the PODR are significant, the meters should be programmed to account for the line and/or transformer losses between the POM and PODR (usually at the POI). In this case, the customer or the consultant shall provide a letter with the line parameters (and/or power transformer) data signed and stamped by a professional engineer.
- Before definition phase, BCH Revenue Metering department should be contacted to discuss the specifics of the project. A complex metering designer responsible for the metering tasks will be assigned at this point.
- During the feasibility/definition phase, the applicant is to send drawings to the assigned project manager, for distribution to the BCH Revenue Metering Department showing the single-line diagram (SLD) and informing

the planned metering scheme, meter cabinet location, as well as any other metering related document for review and approval.

In order to finalize the metering option, the IC of both wind projects will work with BCH to determine the required Revenue Metering configuration in accordance with the Electricity Purchase Agreement and associated agreements. Specific metering information is provided in the table below.

Project Name	██████████ project
Point-of-Metering	138 kV (voltage level), BC Hydro side of the Power transformer
Voltage Transformers	Transformer, Metering-Voltage, 152 kV, Outdoor, 138,000 GRDY/ 80,500-115-115 V (700-1) – TBD by PoR-Supplied by the IC of ██████████ (VT must be CSA certified, and customer to submit certificate document)
Current Transformers	3 x CTs- Metering-Current, 152 kV Max 200x400x800:5-5 A – Ratio – TBD by PoR- Supplied by the IC of ██████████ (CT must be CSA certified, and customer to submit certificate document)

Project Name	██████████ project
Point-of-Metering	138 kV (voltage level), BC Hydro side of the Power transformer
Voltage Transformers	Transformer, Metering-Voltage, 152 kV, Outdoor, 138,000 Grdy/ 80,500-115-115 V (700-1) – TBD by PoR-Supplied by IC of ██████████ (VT must be CSA certified, and customer to submit certificate document)
Current Transformers	3 x CTs- Metering-Current, Outdoor, Dry, 152 kV Max 300x600x1200:5-5 A – Ratio – TBD by PoR- Supplied by IC of ██████████ (CT must be CSA certified, and customer to submit certificate document)

8 Conclusions

This System Impact Study has identified the following requirements and conclusions:

1. Stage 1 — Interconnecting the [REDACTED] project (Proposed COD: Sept 2028).
 - A new 138 kV switching station (temporarily referred to as “KBTX”) is required, on the BCH’s existing circuit 1L244 at or close to the proposed POI, for interconnecting the [REDACTED] project into the BCH system. See note 1 below.

Note 1: with the new switching station KBTX, 1L244 will be segregated into two new lines, temporarily referred to as 1L244_A (NIC-KBTX) and 1L244_B (KBTX-WBK). The 138 kV interconnection line for [REDACTED] project, to be built by the customer, is temporarily referred to as 1L244_C (BEW-KBTX). These temporary line designations will be replaced by permanent ones at a later stage of interconnection study.

- At Stage 1, the power injection from [REDACTED] project does not result in any performance concern in the regional system under system normal or applicable contingencies conditions.

2. Stage 2 — Interconnecting the [REDACTED] project (Proposed COD: Oct 2031).

- The installation of additional station equipment at KBTX is required to accommodate the interconnection of [REDACTED] project. This includes additional circuit breakers, disconnect switches, line terminals, and other station equipment. See Note 2 and Note 3 below.

Note 2: for efficient project delivery, it is recommended to construct the proposed KBTX switching station as a full 4-CB switching station with 4-line terminals in one substation project, combining Stage 1 and Stage 2 station scopes. This approach is advised considering that [REDACTED] and [REDACTED] projects will be connected only three years apart.

Note 3: the 138 kV interconnection line for [REDACTED] project, to be built by the customer, is temporarily referred to as 1L244_D (K2W-KBTX).

- At Stage 2, with the power injection from both [REDACTED] and [REDACTED] projects at KBTX, line 1L244_A is subject to pre-contingency overloads during periods of high surplus generations. To address this

overload, the recommended alternative is permanent relocation of line 1L244_A, i.e. to build a new 138 kV line from NIC to KBTX in parallel with the existing line 1L244 and replace the existing line section after the new line is operational.

- At Stage 2, line 1L244_A, after being permanently relocated, may still experience thermal overloads under contingencies. To address this concern, both ██████████ project and ██████████ project are required to participate in a generation runback remedial action scheme (RAS) based on local detection.
3. Stage 3: when WKTP enters service (Considered ISD: Nov 30, 2032).
- After WKTP, line 1L244_B needs to accommodate additional flow to FBC via the new tie line. This flow pattern change could overload the line 1L244_B under infrequent system normal (N-0) conditions — specifically high wind generations coinciding with summer peak loads at WBK and high transfers on the new tie line. To prevent this overload, the new tie (WBK–REC) needs to remain open at the WBK end in these N-0 conditions; an overload detection on 1L244_B is required at WBK and it will trigger an alarm and trip the tie line if overload is detected under the closed-tie conditions.
 - At Stage 3, any protective or non-protective opening of 1L244_A could result in an instability concern attributed to the addition of the subject cluster. To address this concern, both ██████████ project and ██████████ project are required to participate in a generation shedding RAS for these contingencies.
4. For both ██████████ project and ██████████ project, voltage sags caused by energization of the substation main transformer exceed the limits specified in BC Hydro's TIR. Each IC is required to use point-on-wave (POW) controlled closing with independent pole operated (IPO) 138 kV circuit breakers for mitigating the transformer inrush current.
5. The turbines at ██████████ project and ██████████ project are required to have fault ride-through (FRT) capabilities per BCH's TIR. Using the default settings provided, the fault ride-through performance of the inverters is satisfactory and does not result in unexpected tripping or momentary cessation in dynamic simulations. BC Hydro will follow up on the ride-through settings during the pre-commissioning stage.

6. Both [REDACTED] project and [REDACTED] project are capable to meet its respective dynamic reactive power capability requirement specified in the BC Hydro's TIR Section 6.4.2 over most of the MW operating range (including full to lower MW output) and provide a partial reactive capability at zero MW output provided that the turbine's "STATCOM" option is enabled. This "STATCOM" mode shall be made available to each of the wind turbines at the [REDACTED] project and at the [REDACTED] project.
7. BCH will provide line protections for 1L244_A, 1L244_B, 1L244_C and 1L244_D (BC Hydro end only). As part of the line protection replacements for each of the three lines, telecommunication facilities will be required to accommodate the new protection schemes. The IC of [REDACTED] and the IC of [REDACTED] shall provide required relays, telecom facility and associated equipment at its facilities to accommodate the new protection schemes.
8. Anti-islanding protection is required for both [REDACTED] project and [REDACTED] project and shall be configured in the manner that does not compromise the required ride-through performance.
9. A telecommunication-based anti-islanding Direct Transfer Trip (DTT) scheme is required in accordance with IEEE Std 2800-2022. This DTT scheme will initiate a trip to both [REDACTED] project and [REDACTED] project for any protection tripping or manual opening of the line section 1L244_A (NIC-KBTX) in the pre-WKTP scenario. After WKTP enters service, this DTT scheme requires revision to reflect the updated network configuration.
10. Virtual Inertia Control (VIC), a form of Fast Frequency Response (FFR), is required at both [REDACTED] project and [REDACTED] project. The proposed wind turbine generators (WTG), when equipped with the VIC function, are expected to temporarily boost the MW output to limit the system frequency drop during a major frequency event. The VIC settings should be determined in coordination with BC Hydro in the later stage of interconnection studies.

Appendix A

Schematic Diagram of ██████████ Project and ██████████ ██████████ Project

Figure A-1 shows the plant schematic diagram for the wind projects based on the IC-submitted data.

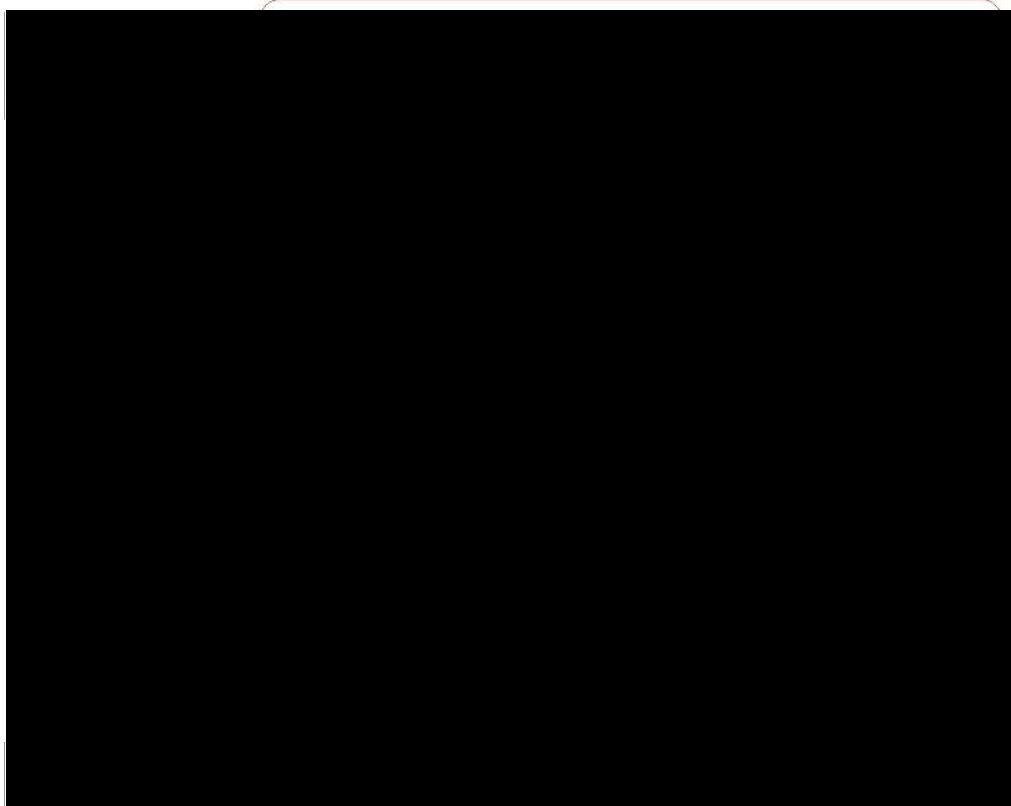

Figure A-1: Schematic Diagram of ██████████ Project and ██████████ Project

Appendix B

Power Flow Study Results

Base Scenario

Error! Reference source not found. and **Error! Reference source not found.** show the key results of power flow studies for the base scenario described in Section 5.1.

Table B-1: Summary of Branch Loading Results in Base Scenario

Case	Area Generations (Note 1)	Contingency		Branch Loading (% of its seasonal normal rating)					
				1L244_A	1L244_B (Note 2)	NIC T5	BCH-FBC New Tie Line (Note 3)	FBC line 50L	FBC line 50L
		Cat.	Description	NIC-KBTX	KBTX-WBK	-	WBK-REC	REC-GL	REC -SAU
Winter Rating				219.9 MVA	192.1 MVA	287 MVA	173.1 MVA	307.9 MVA	202.9 MVA
32HW	Max	P0	System Normal	55	77.4	17.9	35.5	3.7	5.6
	Max	P1.2	1L244_A	0	142.2	6.6	106.3	25.6	33.1
	Max	P1.2	1L244_B	109.4	0	30.5	51.1	23.2	28.5
	Max	P1.2	1L251	52.7	80.1	27.2	38.4	4.6	6.7
	Max	P1.2	5L98	74.3	55.5	22.4	11.4	4.3	4.5
	Max	P1.3	NIC T6	53.9	78.7	25.5	37	4.1	6.2
	Max	P2.1	Open 1L243 at HLD	54.9	77.4	18.2	35.6	3.7	5.7
	Max	P2.1	Open 1L244_B at WBK	122.1	12.7 *	33.2	51.1	23.3	28.5
	Max	P2.3	NIC 1CB18	56.1	76.5	13.7	34.7	3.4	5.3
Max	P2.3	NIC 1CB19	50.4	82.8	37.8	41.4	5.5	7.9	
Summer Rating				169.7 MVA	169.7MVA	287 MVA	173.1 MVA	218 MVA	144.8 MVA
33HS	Max	P0	System Normal	73.3	85.7 *	19.5	22.9	2.5	4.3
	Max	P1.2	1L244_A	0	160.6 *	7.7	95.8	34.1	40.2
	Max	P1.2	1L244_B	141.8	0	31.7	62.8	34.5	47.5
	Max	P1.2	1L251	70.3	88.7 *	28.8	25.8	3.8	4.6
	Max	P1.2	5L98	99.8	59.6 *	24.1	5.1	9.5	15.3
	Max	P1.3	NIC T6	71.3	87.5 *	26.4	24.7	3.3	4.6
	Max	P2.1	Open 1L243 at HLD	73.5	85.4 *	18.8	22.6	2.4	4.3
	Max	P2.1	Open 1L244_B at WBK	158.1	16.4 *	34.5	62.8	34.5	47.5
	Max	P2.3	NIC 1CB18	75.1	84.4 *	14.2	21.7	2	4.3
Max	P2.3	NIC 1CB19	66.9	92.1 *	40	29.2	5.2	5.4	
Summer Rating				169.7 MVA	169.7 MVA	286.8 MVA	173.1 MVA	218 MVA	144.8 MVA
33LS	Max †	P0	System Normal	117.9	41.4 *	8.4	16.6	6.4	5.3
	Max †	P1.2	1L244_A	0	160.0 *	23.3	130.6	52.7	64.4
	Max †	P1.2	1L244_B	141.8	0	8.9	25.1	14.8	19.8
	Max †	P1.2	1L251	114.9	44.3 *	9.8	19.1	7	6
	Max †	P1.2	5L98	143.9	18.4 *	8.7	18.6	12.5	15.4
	Max †	P2.1	Open 1L243 at HLD	114	45.4 *	11.1	20.1	7.3	6.3

	Max †	P2.1	Open 1L244_B at WBK	158.2	16.5 *	10.4	25.1	14.8	19.8
	Max †	P2.3	NIC 1CB18	110.7	48.6 *	21	23	8.1	7.4
	Max †	P2.3	NIC 1CB19	114.8	44.0 *	13.3	18.9	6.9	5.9
<p>Note 1: by default, [redacted] and other generations in the SIW region are set to their MPO, except:</p> <ul style="list-style-type: none"> If marked with "†", Nicola area generation is set to MPO, while Highland area generation (MIG, KCH, QYS, MMW, HVW, SHQ) are set to zero MW output. This is to create a stressed scenario for 1L244 westbound flow. <p>Note 2: by default, the line loading on 1L244_B is measured at WBK end, except:</p> <ul style="list-style-type: none"> If marked with asterisk "*", the line loading is measured on Section from PSW tap to BDM tap. If marked with double asterisk "**", the line loading is measured on Section from KBTX to PSW tap. <p>Note 3: The BCH-FBC new tie line (WBK-REC) is assumed to have a summer continuous rating of 173.1 MVA, and its winter rating is not yet available yet. The summer rating is used as a placeholder in winter cases.</p>									

Table B-2: Selected Bus Voltages for in Base Scenario

Case	IC's Plant Output	Contingency		Bus Voltage (PU)			
		Cat.	Description	NIC 138	KBTX 138	WBK 138	REC 138
32HW	Max	P0	System Normal	1.02	1.02	0.99	0.99
	Max	P1.2	Loss of 1L244_A	1.02	1.01	0.95	0.96
	Max	P1.2	Loss of 1L244_B	1.02	1.03	0.97	0.98
33HS	Max	P0	System Normal	1.02	1.02	0.98	0.99
	Max	P1.2	Loss of 1L244_A	1.02	1.01	0.95	0.96
	Max	P1.2	Loss of 1L244_B	1.02	1.03	0.96	0.97
	Max	P1.2	Loss of 50L (LEE-SEX)	1.02	1.02	0.97	0.97
	0 MW	P1.2	Loss of 50L (LEE-SEX)	1.02	1.02	0.98	0.97
33LS	Max	P0	System Normal	1.02	1.02	0.98	0.99
	Max	P1.2	1L244_A	1.02	1.01	0.95	0.96
	Max	P1.2	1L244_B	1.02	1.03	0.96	0.97

Sensitivity Scenario – only [redacted] Project is Operational.

This sensitivity scenario represents the period between 2028 to 2031, during which only [redacted] project is operational in the NIC-WBK area. This means [redacted] and WKTP are excluded in the study model. Table B-3 shows the branch loading under N-0 and N-1 conditions. It indicates no thermal violations under system normal or single contingencies for this scenario.

Table B-3: Summary of Branch Loading Analysis Results in Sensitivity Scenario ([redacted] and WKTP Excluded)

Case	Area Gen (Note 1)	Contingency		Branch Loading (% of its seasonal normal rating)					
		Cat.	Description	NIC-KBTX	KBTX-WBK	-	WBK-REC	REC-GL	REC-SAU
Winter Rating				219.9 MVA	192.1 MVA	287 MVA	-	-	-
32HW	Max	P0	System Normal	14.6	45	10.1	-	-	-
	Max	P1.2	1L244_A	0	0	7.5	-	-	-
	Max	P1.2	1L244_B	40.6	0	15.3	-	-	-
	Max	P2.1	Open 1L244_B at WBK	53.3	12.7 *	18			

Summer Rating				169.7 MVA	169.7MVA	287 MVA	-	-	-
33HS	Max	P0	System Normal	6.9	62.9 *	8.5	-	-	-
	Max	P0	System Normal † (high transfer on WBK-REC)	19	88	5	-	-	-
	Max	P1.2	1L244_A	0	0	7.5	-	-	-
	Max	P1.2	1L244_B	52.6	0	15.7	-	-	-
	Max	P2.1	Open 1L244_B at WBK	69	16.4 *	18.4			
Summer Rating				169.7 MVA	169.7 MVA	286.8 MVA	-	-	-
33LS	Max †	P0	System Normal	44.8	24.9 *	15.9	-	-	-
	Max †	P1.2	1L244_A	0	0	23	-	-	-
	Max †	P1.2	1L244_B	52.8	0	14.6	-	-	-
	Max †	P2.1	Open 1L244_B at WBK	69.1	16.4 *	12.2			
<p>Note 1: by default, ██████████ and other generations in the SIW region are set to their MPO, except:</p> <ul style="list-style-type: none"> If marked with "†", Nicola area generations are set to their MPO, while Highland area generations (MIG, KCH, QYS, MMW, HVW, SHQ) are set to their lowest output. This is to create a stressed scenario for 1L244 westbound flow. <p>Note 2: by default, the line loading on 1L244_B is measured at WBK end, except:</p> <ul style="list-style-type: none"> If marked with asterisk "**", the line loading is measured on Section from PSW tap to BDM tap. 									

Sensitivity Scenario - Impact Of 500 kV Circuit Flow Pattern Change (i.e. High Transfer on the Future Tie Line WBK-REC)

As mentioned in the Section 5.1, one of the variables that may impact the power flow study result is the power flow pattern on the 500 kV circuits that operate in parallel with the new WBK-REC tie line and 1L244_B.

BC Hydro's West of ACK/VAS Cut Plane consists of three 500 kV circuits (5L98, 5L76, 5L79) that run in parallel with the new tie line between FBC and BCH (WBK-REC). The cut plane flow pattern is expected to impact the WBK-REC tie line flow as well as the line loading on 1L244_A and 1L244_B.

Table B-4 shows power flow study result with a lower power transfer on West of ACK and VAS Cut Plane. It is evident that under N-0 condition, a new thermal overload on 1L244_B section (PSW tap - WBK) may occur under certain system conditions (i.e. high wind generations combined with both heavy summer load condition and a high transfer on WBK-REC tie line).

Further study shows that if the WBK-REC tie is open under these N-0 conditions, 1L244_B overload would not occur.

Table B-4: Summary of Branch Loading Analysis Results in Sensitivity Scenario with a Lower Transfer on West of ACK/VAS Cut Plane

Case	Area Generations	Contingency		Branch Loading (% of its seasonal normal rating)					
				1L244_A	1L244_B (Note 2)	NIC T5	BCH-FBC New Tie Line	FBC line 50L	FBC line 50L
		Cat.	Description	NIC-KBTX	KBTX-WBK	-	WBK-REC	REC-GL	REC-SAU
Winter Rating				219.9 MVA	192.1 MVA	287 MVA	173.1 MVA	807.9 MVA	202.9 MVA
32HW (Note 1)	Max	P0	System Normal	39.8	95.4	14.9	54.7	17.9	0.0
Summer Rating				169.7 MVA	169.7 MVA	287 MVA	173.1 MVA	218 MVA	144.8 MVA
33HS (Note 1)	Max	P0	System Normal	42.8	116.2 *	15.4	52.8	15.5	17
	Max	P0	System Normal † (WBK-REC tie open)	96.4	62.7 *	25.4	0.0	7.2	13.4
	Max	P1.2	1L244_A	0	160.4 *	8.4	95.7	34.1	40.1
	Max	P1.2	1L244_B	141.8	0	33.5	63	34.7	47.6
	Max	P2.1	Open 1L244_B at WBK	157.9	16.4 *	36.2	63.1	34.7	47.7
Summer Rating				169.7 MVA	169.7 MVA	286.8 MVA	173.1 MVA	218 MVA	144.8 MVA
33LS (Note 1)	Max	P0	System Normal	76.7	82.2 *	25.1	52.6	19.6	22.5
	Max	P1.2	1L244_A	0	160.2 *	12.3	128.2	51.6	63.1
	Max	P1.2	1L244_B	141.8	0	36.9	28	16	21.4
	Max	P2.1	Open 1L244_B at WBK	158	16.3 *	39.6	28	16	21.4
<p>Note 1: representative of a low transfer on the West of ACK and VAS Cut Plane (< 100 MW for summer cases; <1000 MW for winter cases).</p> <p>Note 2: by default, the line loading on 1L244_B is measured at WBK end, except:</p> <ul style="list-style-type: none"> If marked with asterisk "**", the line loading is measured on Section from PSW tap to BDM tap. 									

Appendix C

Transient Stability Study Results

Table C-1 shows a summary of the transient stability studies for the load condition (2033LS) selected for the study.

Table C-1: Transient Stability Study Results

Category	Contingency	Fault Location	Fault Clearing Time (Cycles)		System Performance
			Close End	Far End	
P1.2	1L243	Close to NIC	8	9	Acceptable
P1.2	1L251 Zone 2 Clearing	approx. 41 km from NIC	30	n/a	Acceptable
P1.2	1L244_A	Close to KBTX	8	9	Unstable (Note 2)
P1.2	1L244_B	Close to KBTX	8	9	Acceptable
P1.3	NIC T6 (Note1)	n/a	6	n/a	Acceptable
P1.3	WBK T1	n/a	6	n/a	Acceptable
P2.1	Opening 1L244_A at KBTX	n/a	n/a	n/a	Unstable (Note 2)
P2.1	Opening 1L244_B at WBK	n/a	n/a	n/a	Acceptable
P4	1L243 with Stuck NIC 1CB18	Close to NIC	15	8	Acceptable
P4	1L243 with Stuck NIC 1CB17	Close to NIC	15	8	Acceptable
Note 1: NIC T2 is also tripped alongside NIC T6 due to being in the same protection zone. Note 2: For this otherwise unstable contingency, the system performance would be stable if [REDACTED] and [REDACTED] are disconnected from the grid within certain time frame.					



Appendix D

IC Provided Power Flow and Dynamic Models and Data

This appendix summarizes the customer-submitted power flow and dynamic model data for the proposed project and project.

project

[Redacted text block]

[Redacted text block]

[Redacted text block]

[Redacted text block]

[Redacted]	[Redacted]	[Redacted]
[Redacted]	[Redacted]	[Redacted]
[Redacted]	[Redacted]	[Redacted]
[Redacted]	[Redacted]	[Redacted]

[Redacted text block]

[Redacted text block]

[Redacted]	[Redacted]	[Redacted]
[Redacted]	[Redacted]	[Redacted]
[Redacted]	[Redacted]	[Redacted]
[Redacted]	[Redacted]	[Redacted]
[Redacted]	[Redacted]	[Redacted]
[Redacted]	[Redacted]	[Redacted]
[Redacted]	[Redacted]	[Redacted]
[Redacted]	[Redacted]	[Redacted]
[Redacted]	[Redacted]	[Redacted]
[Redacted]	[Redacted]	[Redacted]
[Redacted]	[Redacted]	[Redacted]
[Redacted]	[Redacted]	[Redacted]

Appendix E

Preliminary One-Line Sketch for Future Proposed Switching Station (KBTX)

Figure E-1 shows the preliminary One-Line Sketch for the proposed switching station KBTX at Stage 1 (when only [REDACTED] is put in service).

Figure E-2 shows the preliminary One-Line Sketch for the proposed switching station KBTX at Stage 2 (when both [REDACTED] and [REDACTED] are put in service).

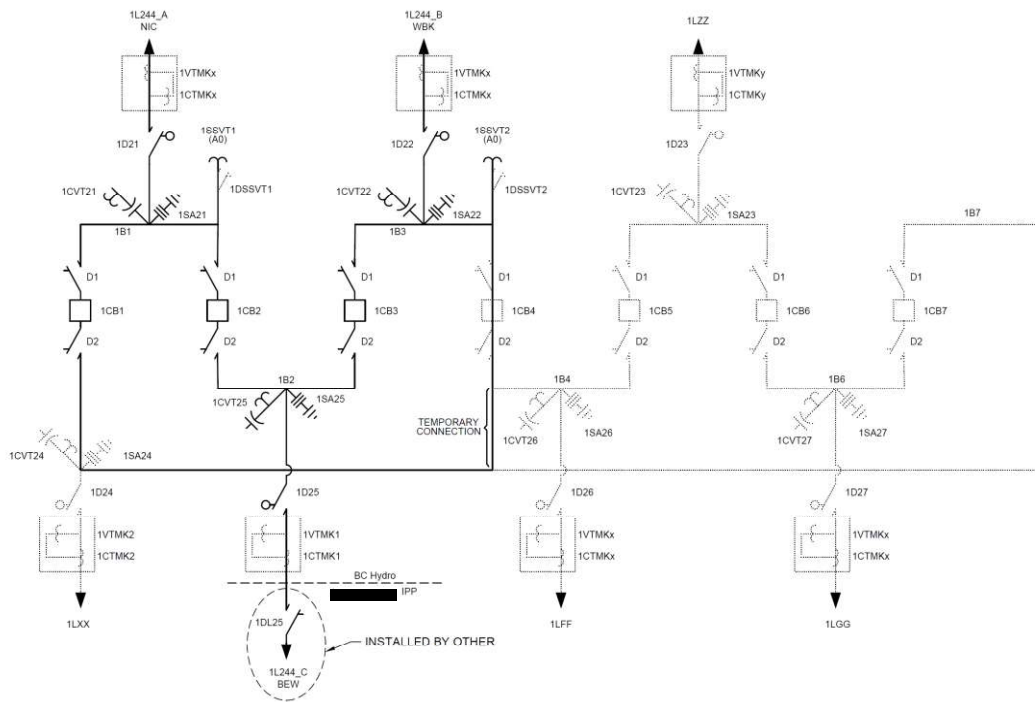

Figure E-1: Preliminary One-Line Sketch for the Proposed Switching Station KBTX at Stage 1

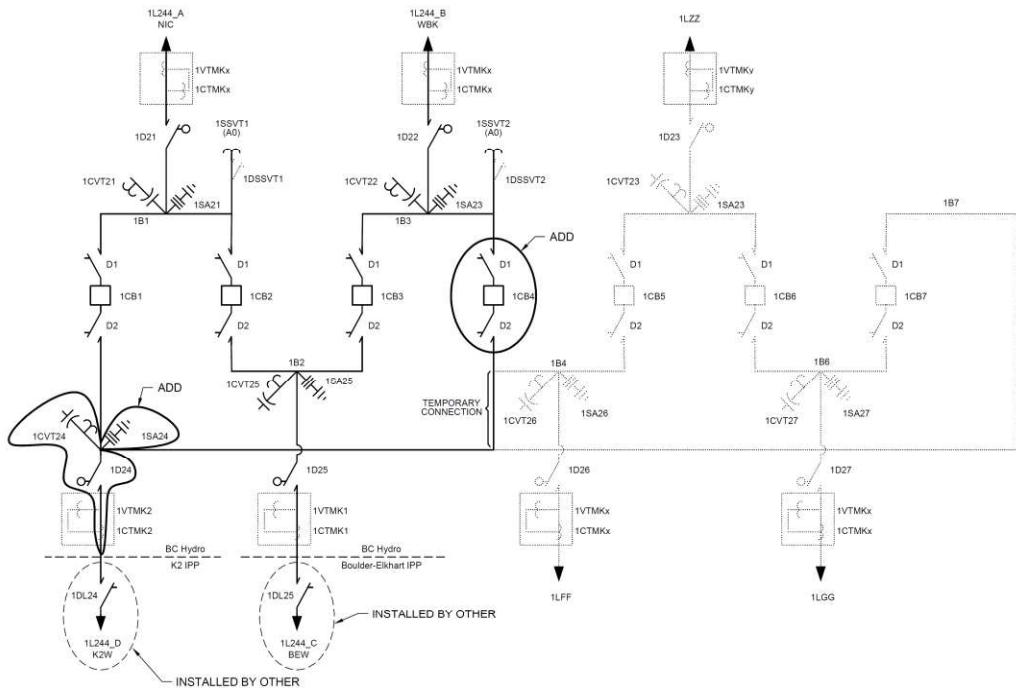

Figure E-2: Preliminary One-Line Sketch for the Proposed Switching Station KBTX at Stage 2

Appendix F

Transmission Line Diagrams and Additional Information

The proposed POI location, the BC Hydro's existing line 1L244 (about 32.4 km from NIC), and the conceptual Ingress and Egress In/Out of proposed switching station KBTX on 1L244 is provided in this appendix.



Figure F-1: Proposed POI Location Diagram

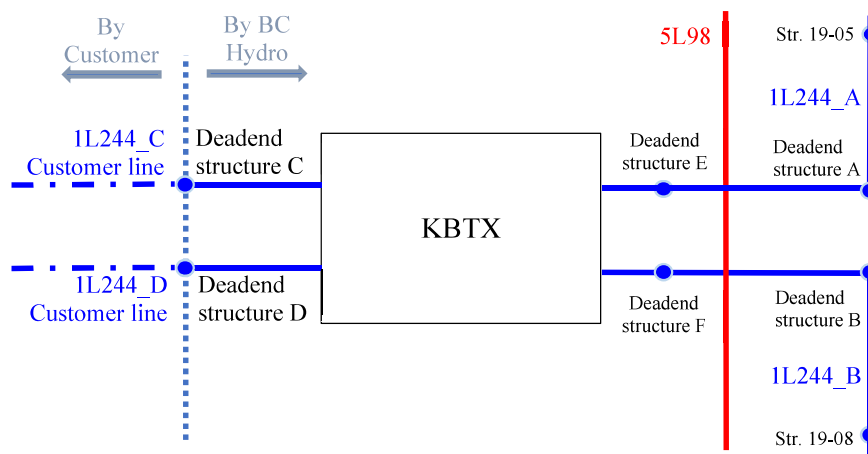

Figure F-2: Conceptual Ingress/Egress (In/Out) of Proposed Switching Station KBTX on the existing line 1L244, adjacent to 5L98

Background on the Existing Line 1L244

1L244_A is about 32.4km long currently with 477 kcmil Hawk ACSR conductor. The existing 5T-10 rating for 1L244 is 677A Summer (30°C) at maximum conductor temperature of 90°C. It is primarily supported on two pole double arm H-frame construction (without cross braces) and three pole dead-end wood pole structures. The existing structures are assumed to be mostly class 2. Only a few structures have K or X-braces installed. Elevations range from 750 to 1550 m. Much of the surrounding area is rangeland or heavily logged. Access appears reasonable and sufficient considering current land use.

Other Alternative Considered for Thermally Upgrading 1L244 A

In addition to the recommended option — permanent relocation of 1L244_A (alternative 1), BC Hydro has considered another alternative for the thermal upgrade of 1L244_A, i.e. reconductoring 1L244_A from NIC to KBTX (alternative 2).

The estimated scope for alternative 2 is as follows.

- Replacement of 75% or 115EA of the existing structures of 1L244_A as the line was built in 1967. Based on the information available on TLDS and LiDAR, many structures are shown to have defects and/ or likely to require more height to meet clearance requirements due to increased sag after reconductoring.
- Reconductoring for a total of 140km of ASC conductor Bluebell or ACSR conductor Crane (1151A or 1054A @ 90°C, exceeding the required 961A)
- The proposed poles are assumed to be mostly BCH standard 65' class 1 wood pole or equivalent.
- Select areas may require FRP poles due to wildfires and wood peckers
- Additional right of way may be required in select areas.

Reconductoring 1L244 (alternative 2) is not recommended, based on issues including outage/ live line work, existing line conditions, etc.

Appendix G

Additional Protection Requirements

This appendix contains additional Protection requirements to supplement those outlined in Section 5.9.1.

Stage 1: ██████████ enters service (COD: 2028)

At stage 1, the IC of ██████████ must submit the following SIGNED and SEALED documents to BC Hydro Protection Planning for protection coordination and documentation at least 6 months prior to the target Interconnection date.

- IFC entrance protection one-line diagram.
- DC schematics of entrance protection relay(s) and wiring diagram that indicates connection to trip coil of entrance breaker.
- DC schematics of incoming RAS transfer trips that indicate connection to entrance breaker trip coils or the controller(s) used for runback; the customer must coordinate with the BCH Remedial Action Scheme Reliability Subcommittee (RASRS) representative to ensure the data provided and associated schedule will allow BCH to obtain RAS approval on time.
- Entrance transformer nameplate drawings.
- Finalized Generator Interconnection Data Form (GIDF).
- Entrance HV interrupting device nameplate with interruption time rating indicated.
- Entrance Protection relay(s) settings.
- BEW 1L244_C Protection relay(s) settings.

At Stage 1, the following P&C work is required at the existing ██████████ wind farm (PSW).

- Retain existing 1L244 SEL-411L-0 protection relays and rename protection to 1L244_B protection.
- Make modifications as needed to PSW protection to accommodate 1L244_B reconfiguration and ██████████ interconnection.

Stage 2: ██████████ enters service (COD: 2031)

At Stage 2, the IC of ██████████ must submit the following SIGNED and SEALED documents to BC Hydro Protection Planning for protection coordination and documentation at least 6 months prior to the target Interconnection date.

- IFC entrance protection one-line diagram.
- DC schematics of entrance protection relay(s) and wiring diagram that indicates connection to trip coil of entrance breaker.
- DC schematics of incoming RAS transfer trips that indicate connection to entrance breaker trip coils or the controller(s) used for runback; the customer must coordinate with the BCH RASRS representative to ensure the data provided and associated schedule will allow BCH to obtain RAS approval on time.
- Entrance transformer nameplate drawings.
- Finalized GIDF.
- Entrance HV interrupting device nameplate with interruption time rating indicated.
- Entrance Protection relay(s) settings.
- K2W 1L244_D Protection relay(s) settings.

At Stage 2, the following P&C work is required at the existing PSW wind farm.

- Modify as needed PSW protection settings to accommodate [REDACTED] farm interconnection.

Appendix H

Telecom Requirements and Telecom Block Diagrams

Below is a summary of Teleprotection, RAS and Telecontrol requirements for Telecom, along with the telecom block diagram that illustrates the telecom solution identified in this SIS.

Teleprotection Requirements for Telecom

- 1) Retain and re-title the existing WECC Level 3 64 kbps synchronous circuits between NIC and PSW for “NIC-PSW 1L244_B PY/SY Digital Teleport”.
- 2) Provide WECC Level 3 64 kbps synchronous circuits between NIC and KBTX for “NIC-KBTX 1L244_A PY/SY Digital Teleport. Physical interface shall be C37.94 optical over multimode fibre using ST connectors.
- 3) Provide WECC Level 3 64 kbps synchronous circuits between KBTX and PSW for “KBTX-PSW 1L244_B PY Digital Teleport” and “KBTX-PSW 1L244_B Teleport”. Physical interface shall be C37.94 optical over multimode fibre using ST connectors.
- 4) Provide WECC Level 3 64 kbps synchronous circuits between KBTX and BEW for “KBTX-BEW 1L244_C PY/SY Teleport Teleport”. Physical interface shall be C37.94 optical over multimode fibre using ST connectors.
- 5) Provide WECC Level 3 64 kbps synchronous circuits between KBTX and K2W for “KBTX-K2W 1L244_D PY/SY Teleport Teleport”. Physical interface shall be C37.94 optical over multimode fibre using ST connectors.
- 6) Provide WECC Level 1 transfer trip facilities from NIC to BEW for “NIC 5L81/5L82/5L83 PY/SY TT (Runback) TO BEW”.
- 7) Provide WECC Level 1 transfer trip facilities from KBTX to BEW for “KBTX 1L244_A Overload PY/SY TT (Runback) TO BEW”.
- 8) Provide WECC Level 1 transfer trip facilities from NIC to K2W for “NIC 5L81/5L82/5L83 PY/SY TT (Runback) TO K2W”.
- 9) Provide WECC Level 1 transfer trip facilities from KBTX to K2W for “KBTX 1L244_A Overload PY/SY TT (Runback) TO K2W”.
- 10) Provide WECC Level 1 transfer trip facilities from NIC to KBTX for “5L76 and 5L79 PY/SY TT to 1L244_B TO K2W”.

Telecontrol Requirements for Telecom

- 1) KBTX SCADA circuit off FVO & SIO.
- 2) KBTX REMACC circuit off EDM.
- 3) BEW SCADA circuit off FVO & SIO.
- 4) K2W SCADA circuit off FVO & SIO.
- 5) NIC RAS RTU (C) SCADA circuit, 19.2 kbps minimum, off ING DCP.

6) NIC RAS RTU (D) SCADA circuit, 19.2 kbps minimum, off SIC DCP

Other Requirements for Telecom

- 1) Provide corporate VPRN circuit at HAM, NIC, and KBTX.
- 2) Assume good cellular data or satellite coverage is available at both K2W and BEW enabling these customers to furnish Revenue Metering and PPIS circuits.

Telecommunication Additions/Upgrades/Removals

All work to be done by BC Hydro unless otherwise indicated.

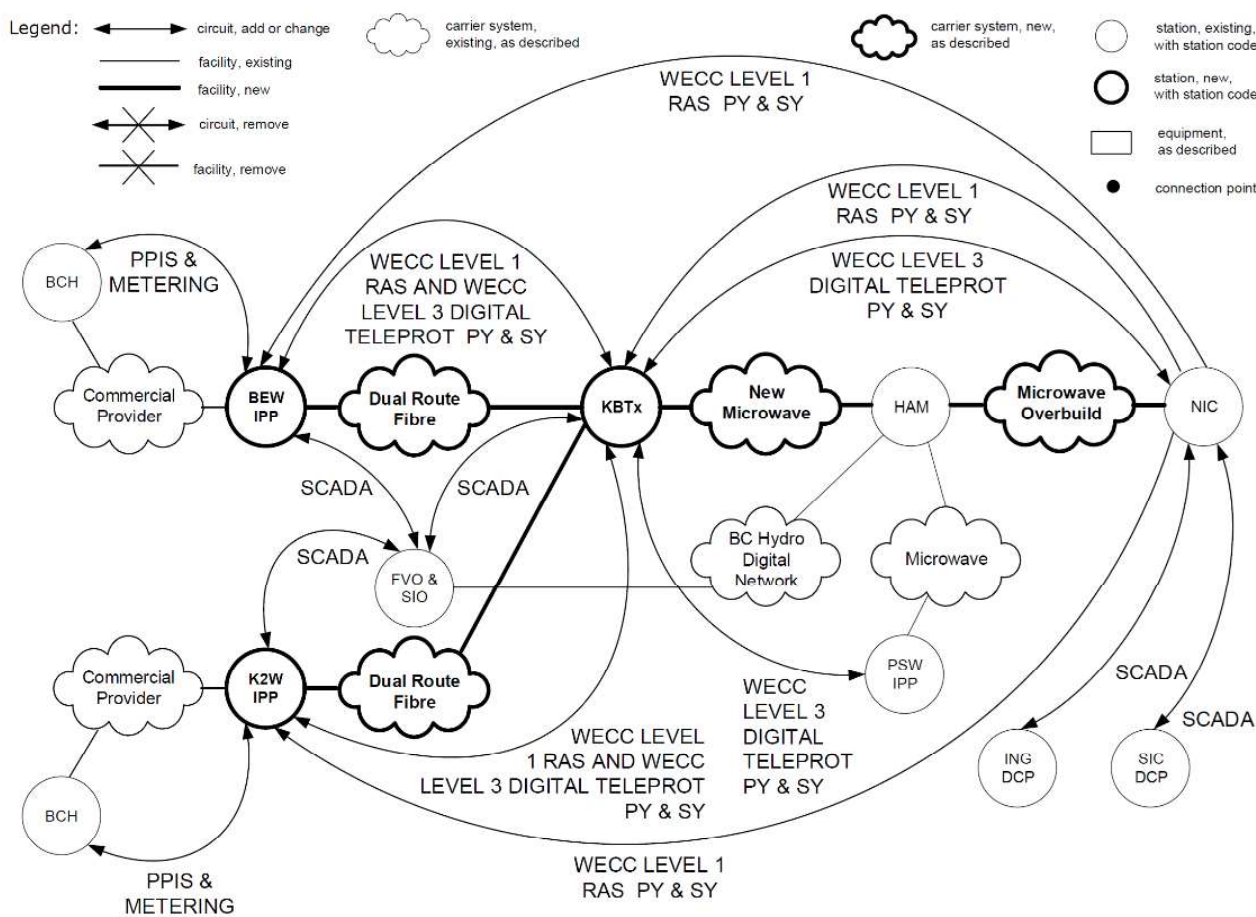

Figure H-1: Telecom block diagram identified for [redacted] and [redacted]

Appendix I

Revenue Metering Related Telecommunications Requirements

A telecommunications channel is required for remote read/download data from the main and the backup meters. The design, supply and installation of the communications equipment shall be coordinated between BCH Revenue Metering, BCH Telecom, the Power Generator and the Telecommunications Service Provider. The PG should provide a terminal / connector inside the BCH meter cabinet. Where the POI is on a 69 kV voltage class or higher BC Hydro transmission system and where a conventional wire-line telephone is installed, ground potential rise (GPR) protection shall be provided. Alternative technologies may be used, e.g., cellular, fiber optic, microwave, satellite etc. However, these solutions must be discussed and approved by BCH before installation. The bottom line is: - BCH MV-90 Server must be able to access and download data from the meters remotely as they do when they dial in a site using a standard phone line (wireless or landline). For more details, please, refer to Section 8 of BCH Revenue Metering Requirements for Complex Metering published at the Revenue Metering webpage and at the BC Hydro external website.